

Consolidated*

1900 Series

Safety Relief Valves

Instruction Manual

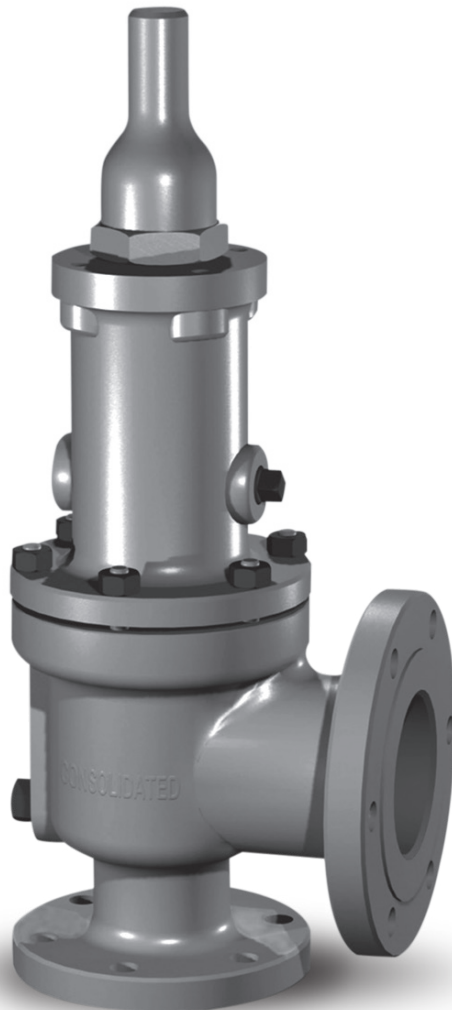

THESE INSTRUCTIONS PROVIDE THE CUSTOMER/OPERATOR WITH IMPORTANT PROJECT-SPECIFIC REFERENCE INFORMATION IN ADDITION TO THE CUSTOMER/OPERATOR'S NORMAL OPERATION AND MAINTENANCE PROCEDURES. SINCE OPERATION AND MAINTENANCE PHILOSOPHIES VARY, GE (GENERAL ELECTRIC COMPANY AND ITS SUBSIDIARIES AND AFFILIATES) DOES NOT ATTEMPT TO DICTATE SPECIFIC PROCEDURES, BUT TO PROVIDE BASIC LIMITATIONS AND REQUIREMENTS CREATED BY THE TYPE OF EQUIPMENT PROVIDED.

THESE INSTRUCTIONS ASSUME THAT OPERATORS ALREADY HAVE A GENERAL UNDERSTANDING OF THE REQUIREMENTS FOR SAFE OPERATION OF MECHANICAL AND ELECTRICAL EQUIPMENT IN POTENTIALLY HAZARDOUS ENVIRONMENTS. THEREFORE, THESE INSTRUCTIONS SHOULD BE INTERPRETED AND APPLIED IN CONJUNCTION WITH THE SAFETY RULES AND REGULATIONS APPLICABLE AT THE SITE AND THE PARTICULAR REQUIREMENTS FOR OPERATION OF OTHER EQUIPMENT AT THE SITE.

THESE INSTRUCTIONS DO NOT PURPORT TO COVER ALL DETAILS OR VARIATIONS IN EQUIPMENT NOR TO PROVIDE FOR EVERY POSSIBLE CONTINGENCY TO BE MET IN CONNECTION WITH INSTALLATION, OPERATION OR MAINTENANCE. SHOULD FURTHER INFORMATION BE DESIRED OR SHOULD PARTICULAR PROBLEMS ARISE WHICH ARE NOT COVERED SUFFICIENTLY FOR THE CUSTOMER/OPERATOR'S PURPOSES THE MATTER SHOULD BE REFERRED TO GE.

THE RIGHTS, OBLIGATIONS AND LIABILITIES OF GE AND THE CUSTOMER/OPERATOR ARE STRICTLY LIMITED TO THOSE EXPRESSLY PROVIDED IN THE CONTRACT RELATING TO THE SUPPLY OF THE EQUIPMENT. NO ADDITIONAL REPRESENTATIONS OR WARRANTIES BY GE REGARDING THE EQUIPMENT OR ITS USE ARE GIVEN OR IMPLIED BY THE ISSUE OF THESE INSTRUCTIONS.

THESE INSTRUCTIONS ARE FURNISHED TO THE CUSTOMER/OPERATOR SOLELY TO ASSIST IN THE INSTALLATION, TESTING, OPERATION, AND/OR MAINTENANCE OF THE EQUIPMENT DESCRIBED. THIS DOCUMENT SHALL NOT BE REPRODUCED IN WHOLE OR IN PART WITHOUT THE WRITTEN APPROVAL OF GE.

Conversion Table

All the United States Customary System (USCS) values are converted to metric values using the following conversion factors:

USCS Unit	Conversion Factor	Metric Unit
in.	25.4	mm
lb.	0.4535924	kg
in ²	6.4516	cm ²
ft ³ /min	0.02831685	m ³ /min
gal/min	3.785412	L/min
lb/hr	0.4535924	kg/hr
psig	0.06894757	barg
ft lb	1.3558181	Nm
°F	5/9 (°F-32)	°C

Note: Multiply USCS value with conversion factor to get metric value.

NOTICE

For valve configurations not listed in this manual, please contact your local Green Tag* Center for assistance.

Contents

I.	Product Safety Sign and Label System	6
II.	Safety Alerts	7
	Read - Understand - Practice	7
III.	Safety Notice	8
IV.	Warranty Information	9
V.	Terminology for Safety Relief Valves	10
VI.	Handling and Storage	11
	Handling	11
	Storage	11
VII.	Pre-Installation and Installation Instructions	11
VIII.	Design Features and Nomenclature	12
	Cap and Lever Interchangeability	12
	Design Simplicity	12
	Nomenclature Related to Design Features	12
	Simple Blowdown Adjustment	12
	Valve Interchangeability	12
IX.	Introduction	12
X.	Consolidated 1900 Series Safety Relief Valve	13
	A. Metal Seat Valve	13
	B. Standard Cap Types	14
	C. Bellows Metal Seat Valve	15
	D. V-W Bellows Metal Seat Valve	16
	E. Soft Seat Valve	17
XI.	Recommended Installation Practices	18
	A. Mounting Position	18
	B. Inlet Piping	18
	C. Outlet Piping	19
XII.	Disassembly of 1900 Series Safety Relief Valves	20
	A. General Information	20
	B. SRV Disassembly	20
	C. Cleaning	23
XIII.	Maintenance Instructions	24
	A. General Information	24
	B. Lapping Nozzle Seats (Non-O-Ring Styles)	24
	C. Lapped Nozzle Seat Widths	25
	D. Lapping Disc Seats	27
	E. Precautions and Hints for Lapping Seats	27
	F. Lapping O-Ring Seating Surfaces	28
	H. Re-Machining Nozzle Seats and Bores	28
	I. Re-Machining the Disc Seat	29
	J. Checking Spindle Concentricity	29
	K. Set Pressure Change-Disc Holder	30
	L. Checking Lift on Restricted Lift Valves	30
	M. Determining the Correct Limit Washer Length	32

XIV.	Inspection and Part Replacement	34
	A. Nozzle Inspection Criteria	34
	B. Nozzle Seat Width	34
	C. Nozzle Bore Inspection	34
	D. 1900 Series SRV Standard Disc Inspection Areas	34
	E. 1900 Series Thermodisc* Replacement Criteria	34
	F. Disc Holder Inspection Criteria	39
	G. Guide Inspection Criteria	42
	H. Spindle Inspection Criteria	42
	I. Spring Inspection Criteria	43
XV.	Reassembly of 1900 Series SRV	44
	A. General Information	44
	B. Preparation	44
	C. Lubrication	44
	D. Reassembly Procedure	44
XVI.	Setting and Testing	51
	A. General Information	51
	B. Test Equipment	51
	C. Test Media	51
	D. Setting the Valve	51
	E. Set Pressure Compensation	51
	F. Setting the Pressure	53
	G. Seat Tightness Testing	53
	H. Recommended Backpressure Testing for Joint Leakage	55
	I. Blowdown Adjustment	55
	J. Hydrostatic Testing and Gagging	56
	K. Manual Popping of the Valve	56
XVII.	Troubleshooting 1900 Series SRVs	57
XVIII.	1900 Series Safety Relief Valve Options	58
	A. General Information	58
	B. Conversion from Conventional to Bellows Type	58
	C. Conversion from Bellows to Conventional Type	60
	D. Optional Glide-Aloy™ Parts	61
XIX.	Maintenance Tools and Supplies	62
	A. Lapping Tools	63
XX.	Replacement Parts Planning	64
	A. Basic Guidelines	64
	B. Replacement Parts List	64
	C. Identification and Ordering Essentials	64
XXI.	Genuine Consolidated Parts	65
XXII.	Recommended Spare Parts for 1900 Series SRVs	66
XXIII.	Manufacturer's Field Service, Repair and Training Program	68
	A. Field Service	68
	B. Factory Repair Facilities	69
	C. SRV Maintenance Training	69
	D. Self-Study Edition of the 1900 Series SRV	69

I. Product Safety Sign and Label System

If and when required, appropriate safety labels have been included in the rectangular margin blocks throughout this manual. Safety labels are vertically oriented rectangles as shown in the **representative** examples (below), consisting of three panels encircled by a narrow border. The panels can contain four messages which communicate:

- The level of hazard seriousness
- The nature of the hazard
- The consequence of human, or product, interaction with the hazard.
- The instructions, if necessary, on how to avoid the hazard.

The top panel of the format contains a signal word (DANGER, WARNING, CAUTION or ATTENTION) which communicates the level of hazard seriousness.

The center panel contains a pictorial which communicates the nature of the hazard, and the possible consequence of human or product interaction with the hazard. In some instances of human hazards the pictorial may, instead, depict what preventive measures to take, such as wearing protective equipment.

The bottom panel may contain an instruction message on how to avoid the hazard. In the case of human hazard, this message may also contain a more precise definition of the hazard, and the consequences of human interaction with the hazard, than can be communicated solely by the pictorial.

①

DANGER — Immediate hazards which WILL result in severe personal injury or death.

②

WARNING — Hazards or unsafe practices which COULD result in severe personal injury or death.

③

CAUTION — Hazards or unsafe practices which COULD result in minor personal injury.

④

ATTENTION — Hazards or unsafe practices which COULD result in product or property damage.



II. Safety Alerts

Read - Understand - Practice

Danger Alerts

A DANGER alert describes actions that may cause severe personal injury or death. In addition, it may provide preventive measures to avoid severe personal injury or death.

DANGER alerts are not all-inclusive. GE cannot know all conceivable service methods nor evaluate all potential hazards. Dangers include:

- High temperature/pressure can cause injury. Ensure all system pressure is absent before repairing or removing valves.
- Do not stand in front of a valve outlet when discharging. STAND CLEAR OF VALVE to avoid exposure to trapped, corrosive media.
- Exercise extreme caution when inspecting a pressure relief valve for leakage.
- Allow the system to cool to room temperature before cleaning, servicing, or repairing. Hot components or fluids can cause severe personal injury or death.
- Always read and comply with safety labels on all containers. Do not remove or deface container labels. Improper handling or misuse could result in severe personal injury or death.
- Never use pressurized fluids/gas/air to clean clothing or body parts. Never use body parts to check for leaks, flow rates, or areas. Pressurized fluids/gas/air injected into or near the body can cause severe personal injury or death.
- It is the owner's responsibility to specify and provide protective wear to protect persons from pressurized or heated parts. Contact with pressurized or heated parts can result in severe personal injury or death.

- Do not work or allow anyone under the influence of intoxicants or narcotics to work on or around pressurized systems. Workers under the influence of intoxicants or narcotics are a hazard to themselves and other employees. Actions taken by an intoxicated employee can result in severe personal injury or death to themselves or others.
- Always perform correct service and repair. Incorrect service and repair can result in product or property damage or severe personal injury or death.
- Always use the correct tool for a job. The misuse of a tool or the use of an improper tool can result in personal injury, damage to product or property.
- Ensure the proper "health physics" procedures are followed, if applicable, before starting operation in a radioactive environment.

Caution Alerts

A CAUTION alert describes actions that may result in a personal injury. In addition, they may describe preventive measures that must be taken to avoid personal injury. Cautions include:

- Heed all service manual warnings. Read installation instructions before installing valve(s).
- Wear hearing protection when testing or operating valves.
- Wear appropriate eye and clothing protection.
- Wear protective breathing apparatus to protect against toxic media.

III. Safety Notice

Proper installation and start-up is essential to the safe and reliable operation of all valve products. The relevant procedures recommended by GE, and described in these instructions, are effective methods of performing the required tasks.

It is important to note that these instructions contain various “safety messages” which should be carefully read in order to minimize the risk of personal injury, or the possibility that improper procedures will be followed which may damage the involved GE product, or render it unsafe. It is also important to understand that these “safety messages” are not exhaustive. GE can not possibly know, evaluate, and advise any customer of all of the conceivable ways in which tasks might be performed, or of the possible hazardous consequences of each way. Consequently, GE has not undertaken any such broad evaluation and, thus, anyone who uses a procedure and/or tool, which is not recommended by GE, or deviates from GE recommendations, must be thoroughly satisfied that neither personal safety, nor valve safety, will be jeopardized by the method and/or tools selected. If not so satisfied, please contact your local Green Tag Center if there are any questions relative to procedures and/or tools.

The installation and start-up of valves and/or valve products may involve proximity to fluids at extremely high pressure and/or temperature. Consequently, every precaution should be taken to prevent injury to personnel during the performance of any procedure. These precautions should consist of, but are not limited to, ear drum protection, eye protection, and the use of protective clothing, (i.e., gloves, etc.) when personnel are in, or around, a valve work area. Due to the various circumstances and conditions in which these operations may be performed on GE products, and the possible hazardous consequences of each way, GE can not possibly evaluate all conditions that might injure personnel or equipment. Nevertheless, GE does offer certain Safety Alerts, listed in Section II, for customer information only.

It is the responsibility of the purchaser or user of GE valves/equipment to adequately train all personnel who will be working with the involved valves/equipment. For more information on training schedules, call 318/640-6054. Further, prior to working with the involved valves/equipment, personnel who are to perform such work should become thoroughly familiar with the contents of these instructions.



IV. Warranty Information

Warranty Statement:⁽¹⁾ GE warrants that its products and work will meet all applicable specifications and other specific product and work requirements (including those of performance), if any, and will be free from defects in material and workmanship.

CAUTION

Defective and nonconforming items must be held for GE's inspection and returned to the original F.O.B point upon request.

Incorrect Selection or Misapplication of Products: GE cannot be responsible for customer's incorrect selection or misapplication of our products.

Unauthorized Repair work: GE has not authorized any non-GE affiliated repair companies, contractors or individuals to perform warranty repair service on new products or field repaired products of its manufacture. Therefore customers contracting such repair services from unauthorized sources must do at their own risk.

Unauthorized Removal of Seals: All new valves and valves repaired in the field by GE Field Service are sealed to assure the customer of our guarantee against defective workmanship. Unauthorized removal and/or breakage of this seal will negate our warranty.

⁽¹⁾ Refer to GE's Standard Terms of Sale for complete details on warranty and limitation of remedy and liability.

⚠ CAUTION

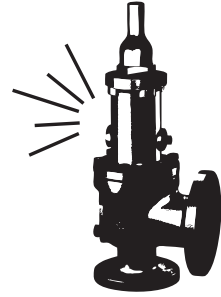

Defective and nonconforming items must be inspected by GE

⚠ CAUTION

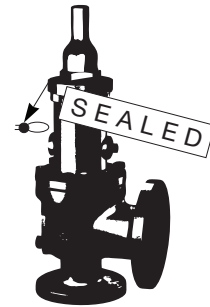

Removal and/or breakage of seal will negate our warranty.

V. Terminology for Safety Relief Valves

- **Accumulation** - the pressure increase over the maximum allowable working pressure of the vessel during discharge through the SRV, expressed as a percentage of that pressure or in actual pressure units.
- **Backpressure** - the pressure on the discharge side of the SRV:
 - Built-up backpressure - the pressure that develops at the valve outlet, after the SRV has been opened, as a result of flow.
 - Superimposed backpressure - the pressure in the discharge header before the SRV is opened.
 - Constant backpressure - the superimposed backpressure that is constant with time.
 - Variable backpressure - the superimposed backpressure that varies with time.
- **Blowdown** - the difference between set pressure and re-seating pressure of the SRV, expressed as a percentage of the set pressure or in actual pressure units.
- **Cold Differential Set Pressure** - the pressure at which the valve is adjusted to open on the test stand. This pressure includes the corrections for backpressure and/or temperature service conditions.
- **Differential Between Operating and Set Pressures** - Valves in installed process services will generally give best results if the operating pressure does not exceed 90% of the set pressure. However, on pump and compressor discharge lines, the differential required between the operating and set pressures may be greater because of pressure pulsations coming from a reciprocating piston. The valve should be set as far above the operating pressure as possible.
- **Lift** - the actual travel of the disc away from the closed position when a valve is relieving.
- **Maximum Allowable Working Pressure** - the maximum gauge pressure permissible in a vessel at a designated temperature. A vessel may not be operated above this pressure, or its equivalent, at any metal temperature other than that used in its design. Consequently, for that metal temperature, it is the highest pressure at which the primary pressure SRV is set to open.
- **Operating Pressure** - the gauge pressure to which the vessel is normally subjected in service. A suitable margin is provided between operating pressure and maximum allowable working pressure. For assured safe operation, the operating pressure should be at least 10% under the maximum allowable working pressure or 5 psi (.34 bar), whichever is greater.
- **Overpressure** - a pressure increase over the set pressure of the primary relieving device. Overpressure is similar to accumulation when the relieving device is set at the maximum allowable working pressure of the vessel. Normally, overpressure is expressed as a percentage of set pressure.
- **Rated Capacity** - the percentage of measured flow at an authorized percent overpressure permitted by the applicable code. Rated capacity is generally expressed in pounds per hour (lb/hr) for vapors, standard cubic feet per minute (SCFM) or m³/min for gases, and in gallons per minute (GPM) for liquids.
- **Relief Valve** - an automatic pressure-relieving device, actuated by static pressure upstream from the valve. A relief valve is used primarily for liquid service.
- **Safety Relief Valve (SRV)** - an automatic pressure-relieving device used as either a safety or relief valve, depending upon application. The SRV is used to protect personnel and equipment by preventing excessive overpressure.
- **Safety Valve** - an automatic pressure-relieving device actuated by the static pressure upstream of the valve, and characterized by a rapid opening or “pop” action. It is used for steam, gas, or vapor service.
- **Set Pressure** - the gauge pressure at the valve inlet for which the relief valve has been adjusted to open under service conditions. In liquid service, the inlet pressure at which the valve starts to discharge determines set pressure. In gas or vapor service, the inlet pressure at which the valve pops determines the set pressure.
- **Simmer** - the audible passage of a gas or vapor across the seating surfaces just before “pop.” The difference between this start-to-open pressure and the set pressure is called “simmer.” Simmer is generally expressed as a percentage of set pressure.

VI. Handling and Storage

Handling

Always keep the inlet flange down on a crated or uncrated flange valve to prevent misalignment and damage to valve internals.

ATTENTION!

Never lift the full weight of the valve by the lifting lever.

ATTENTION!

Do not rotate the valve horizontally or lift/carry using the lifting lever.

Wrap a chain or sling around the discharge neck and around the upper bonnet structure to move or hoist an uncrated valve. Ensure the valve is in a vertical position during the lift.

ATTENTION!

Handle carefully. Do not drop or strike the valve.

Do not subject SRVs, either crated or uncrated, to sharp impact. Ensure that the valve is not bumped or dropped during loading or unloading from a truck. While hoisting the valve, take care to prevent bumping the valve against steel structures and other objects.

ATTENTION!

Prevent dust and debris from entering inlet or outlet of the valve

Storage

Store SRVs in a dry environment and protect them from the weather. Do not remove the valve from the skids or crates until immediately before installation.

Do not remove flange protectors and seating plugs until the valve is ready to be bolted into place during the installation.

VII. Pre-Installation and Installation Instructions

When SRVs are uncrated and the flange protectors or sealing plugs are removed, exercise meticulous care to prevent dirt and other foreign materials from entering the inlet and outlet ports while bolting the valve in place.

VIII. Design Features and Nomenclature

Cap and Lever Interchangeability

In the field, it is often necessary to change the type of cap or lever after a valve has been installed. All flanged Consolidated SRVs are designed to be converted to any type of lever or cap desired. It is not necessary to remove the SRV from the installation, nor will the set pressure be affected when making such a change.

Design Simplicity

Consolidated SRVs have few component parts, resulting in savings by minimizing spare parts inventory and simplifying valve maintenance.

Nomenclature Related to Design Features

The nomenclature of the components of 1900 Series valves, including those with design options for universal media, universal media soft-seat bellows, O-ring seat, liquid trim, and Thermodisc, is identified in Figures 1 through 10.

Simple Blowdown Adjustment

The Consolidated single blowdown ring design makes it possible to set and test a valve at the customer's shop when it is impractical to set and media may be very low, the ring can be positioned so that the set point can be observed without damaging the valve. Blowdown can be attained by positioning the ring in accordance with the adjusting ring position (see Tables 12 through 14).

Valve Interchangeability

A standard Consolidated SRV may be converted to the universal media, universal media soft-seat bellows type, the o-ring seat seal type, etc., and vice versa. Should conversion be required, this interchangeability lowers costs and requires fewer new parts than replacing entire valve types.

IX. Introduction

The safety relief valve (SRV) is an automatic, pressure-actuated relieving device suitable for use either as a safety valve or relief valve, depending on application.

SRVs are used on hundreds of different applications, including liquids and hydrocarbons; therefore, the valve is designed to meet many requirements.

The 1900 Series valves included in this manual may be used to meet the requirements for ASME Section III and Section VIII. They cannot be used on ASME Code Section I steam boilers or superheaters, but may be used on process steam.

X. Consolidated 1900 Series Safety Relief Valve

A. Metal Seat Valve

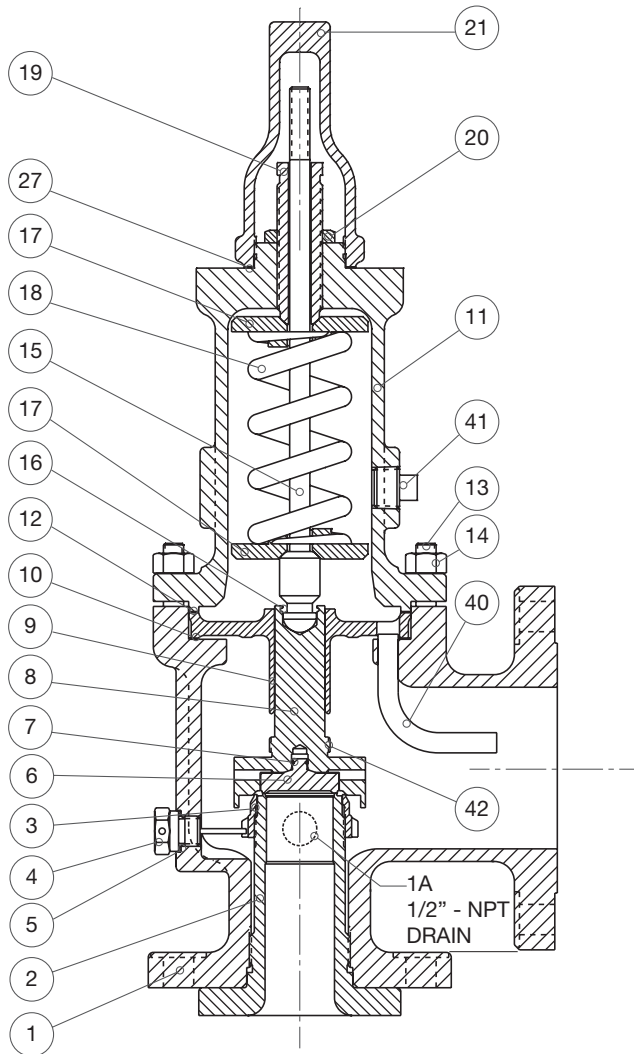

Figure 1: Conventional Metal Seat Valve

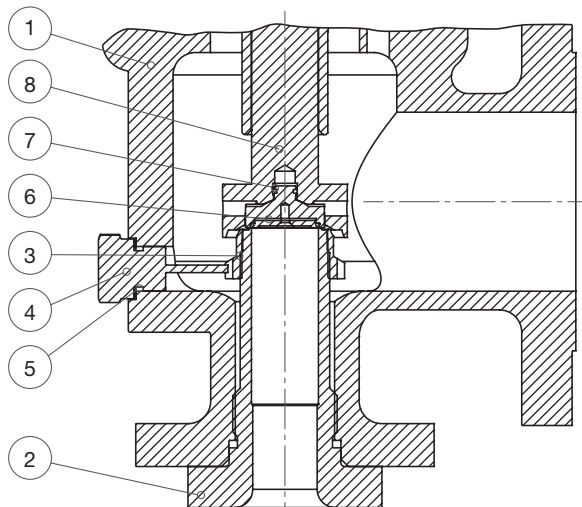

Figure 2: UM Metal Seat Valve

Part No.	Nomenclature
1	Base
2	Nozzle
3	Adjusting Ring
4	Adjusting Ring Pin
5	Adjusting Ring Pin Gasket
6	Disc
7	Disc Retainer
8	Disc Holder
9	Guide
10	Guide Gasket
11	Bonnet
12	Bonnet Gasket
13	Base Stud
14	Stud Nut
15	Spindle
16	Spindle Retainer
17	Spring Washer
18	Spring
19	Adjusting Screw
20	Adjusting Screw Locknut
21	Screwed Cap
27	Cap Gasket
40	Eductor Tube
41	Bonnet Plug
42	Limit Washer ⁽¹⁾

⁽¹⁾Refer to page 32 and Figure 28 page 33 for more details.

X. Consolidated 1900 Series Safety Relief Valve (Contd.)

B. Standard Cap Types

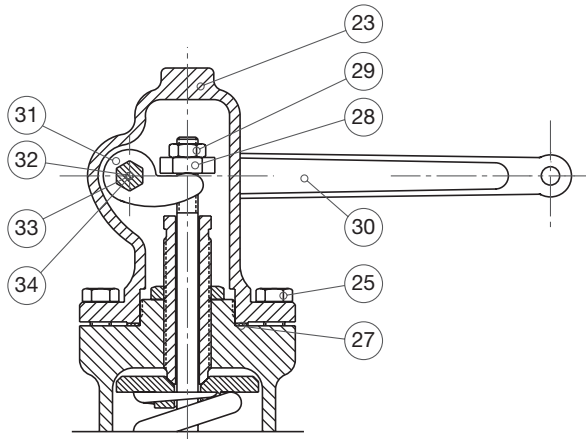

Figure 3: Packed Cap

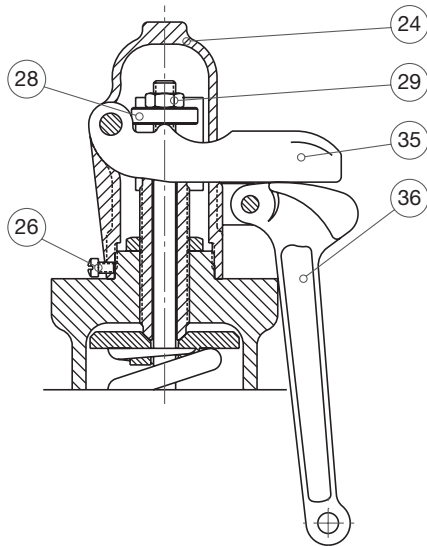

Figure 4: Plain Cap

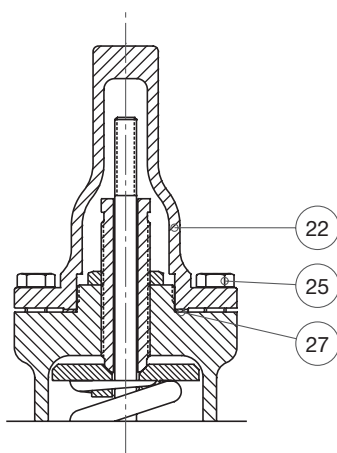

Figure 5: Bolted Cap

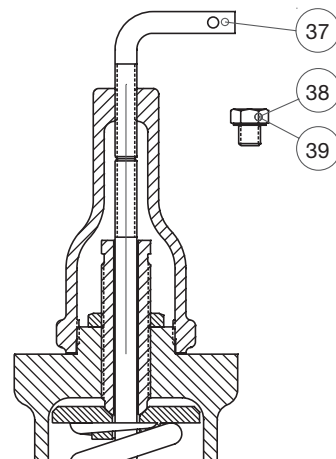

Figure 6: Cap with Gag

Part No.	Nomenclature
22	Bolted Cap
23	Packed Cap
24	Plain Cap
25	Cap Bolt
26	Cap Set Screw
27	Cap Gasket
28	Release Nut
29	Release Locknut
30	Lever
31	Lifting Fork
32	Lever Shaft
33	Packing
34	Packing Nut
35	Top Lever
36	Drop Lever
37	Gag
38	Sealing Plug
39	Sealing Plug Gasket

X. Consolidated 1900 Series Safety Relief Valve (Contd.)

C. Bellows Metal Seat Valve

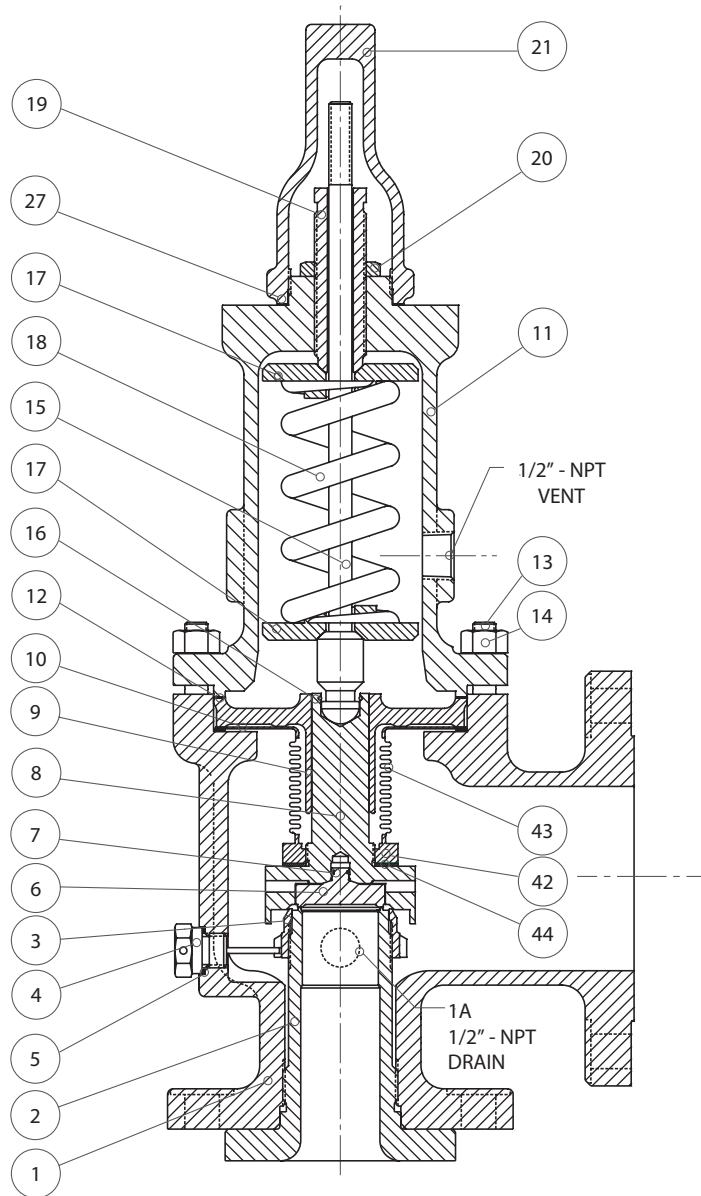

Figure 7: Bellows Metal Seat Valve Construction

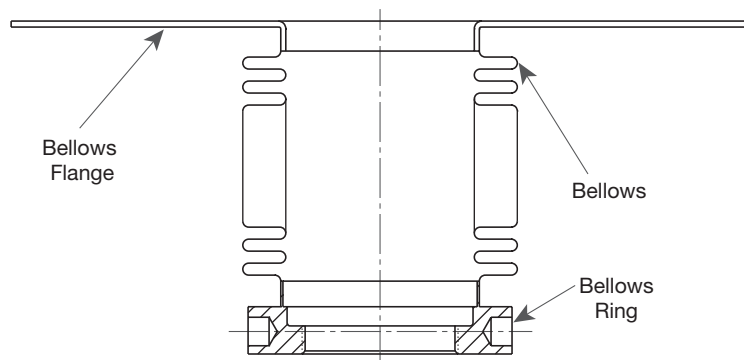

Figure 8: Bellows Assembly

Part No.	Nomenclature
1	Base
1A	Base Plug
2	Nozzle
3	Adjusting Ring
4	Adjusting Ring Pin
5	Adjusting Ring Pin Gasket
6	Disc
7	Disc Retainer
8	Disc Holder
9	Guide
10	Guide Gasket
11	Bonnet
12	Bonnet Gasket
13	Base Stud
14	Stud Nut
15	Spindle
16	Spindle Retainer
17	Spring Washer
18	Spring
19	Adjusting Screw
20	Adjusting Screw Locknut
21	Screwed Cap
27	Cap Gasket
42	Limit Washer ⁽¹⁾
43	Bellows
44	Bellows gasket

⁽¹⁾Refer to page 32 and Figure 28 page 33 for more details.

X. Consolidated 1900 Series Safety Relief Valve (Contd.)

D. V-W Bellows Metal Seat Valve

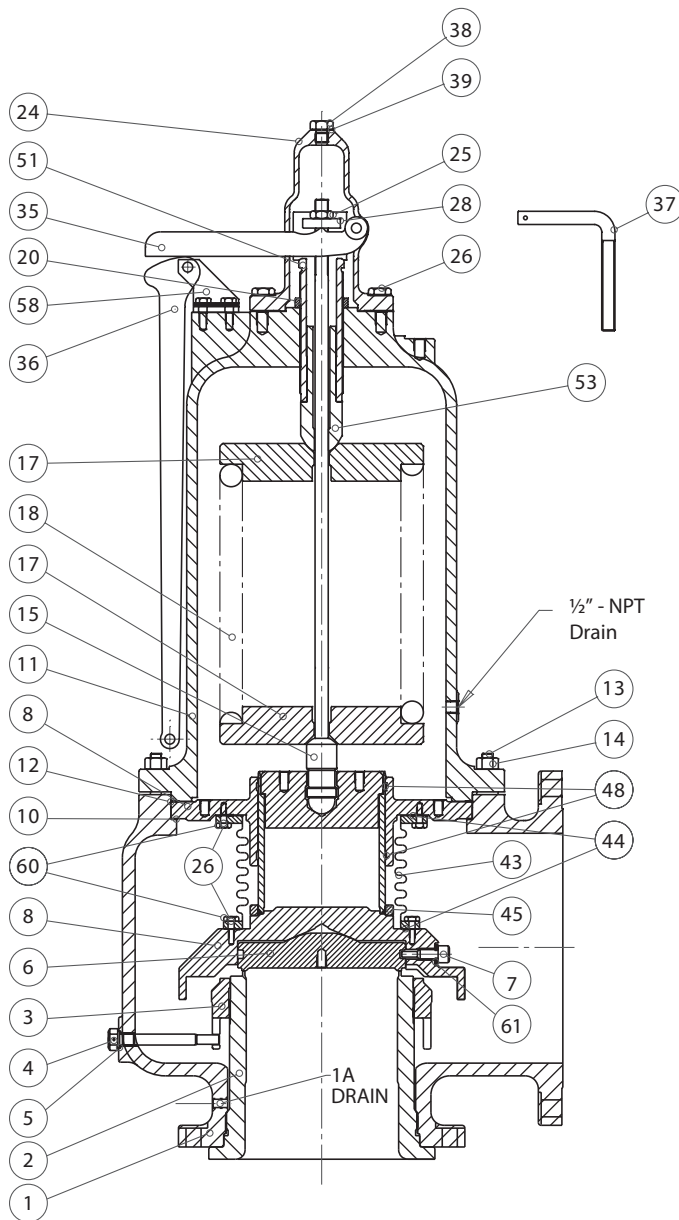

Figure 9: V & W Orifice Valve Construction

Part No.	Nomenclature
1	Base
2	Nozzle
3	Adjusting Ring
4	Adjusting Ring Pin
5	Adjusting Ring Pin Gasket
6	Disc
7	Disc Retainer
8	Disc Holder
9	Guide
10	Guide Gasket
11	Bonnet
12	Bonnet Gasket
13	Base Stud
14	Stud Nut
15	Spindle
16	Spindle Retainer
17	Spring Washer
18	Spring
19	Adjusting Screw
20	Compression Screw Locknut
24	Plain Cap
25	Release Locknut
26	Cap Set Screw
28	Release Nut
35	Top Lever
36	Drop Lever
37	Gag
38	Sealing Plug
39	Sealing Plug Gasket
43	Bellows
44	Bellows gasket
45	Overlift Restrictor
48	Guide Rings
51	Compression Screw
53	Spring Plunger
58	Clevis
60	Lockscrew Washer (Bellows)
61	Retainer Screw Lockwasher

X. Consolidated 1900 Series Safety Relief Valve (Contd.)

E. Soft Seat Valve

Conventional O-Ring Soft Seat Valve

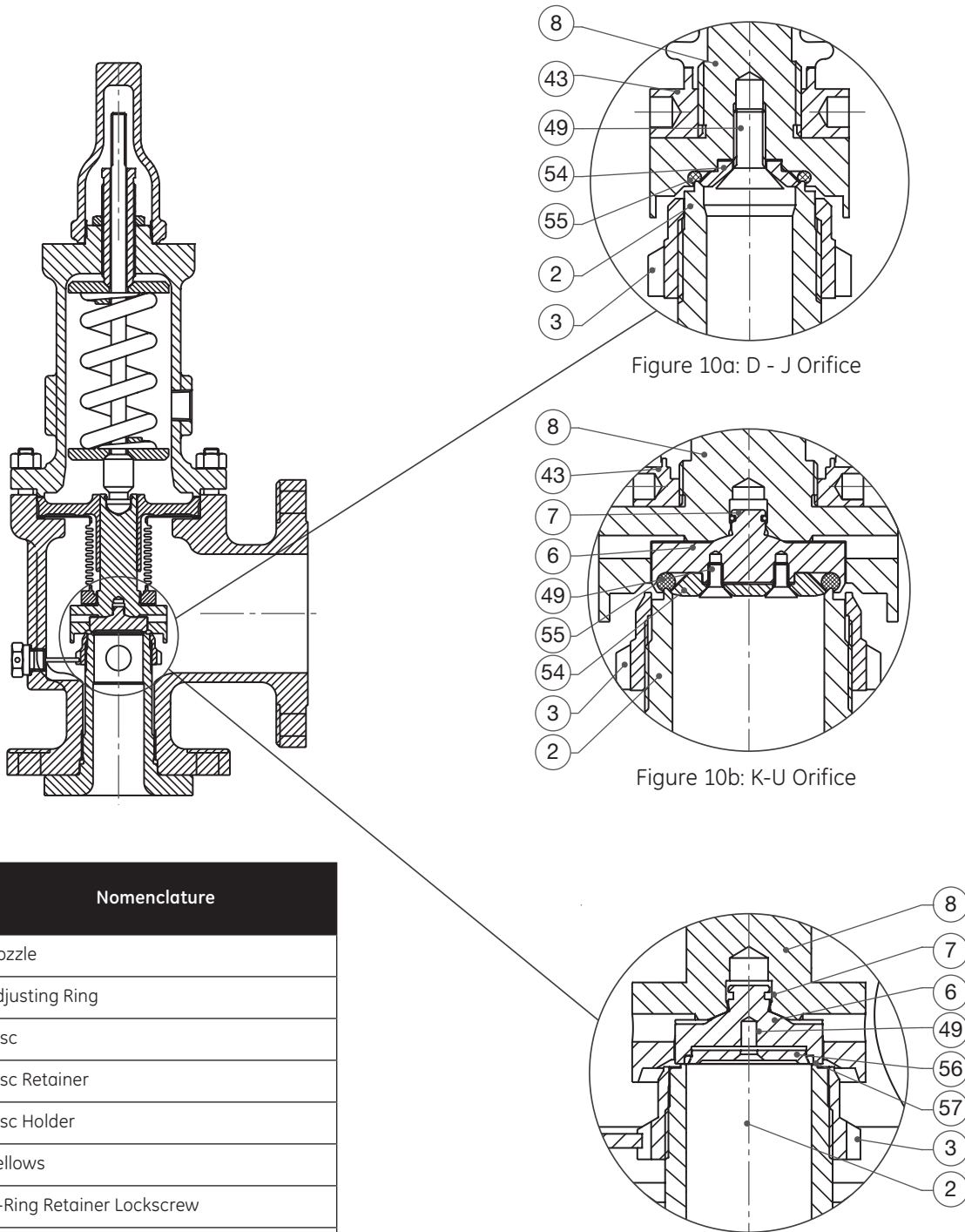

Part No.	Nomenclature
2	Nozzle
3	Adjusting Ring
6	Disc
7	Disc Retainer
8	Disc Holder
43	Bellows
49	O-Ring Retainer Lockscrew
54	O-Ring Retainer
55	O-Ring Seat Seal
56	Soft Seat retainer
57	Teflon™ Steel

Figure 10c: UM Teflon™ Seal

Figure 10: Soft Seat Valve Construction

XI. Recommended Installation Practices

⚠ DANGER

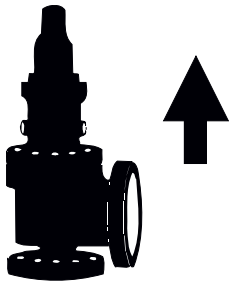

Mount safety relief valves in a vertical, upright position only.

A. Mounting Position

Mount SRVs in a vertical (upright) position (in accordance with API RP 520). Installing a safety relief valve in any position other than vertical (± 1 degree) will adversely affect its operation as a result of the induced misalignment of moving parts.

A stop valve may be placed between the pressure vessel and its relief valve only as permitted by code regulations. If a stop valve is located between the pressure vessel and SRV, the stop valve port area should equal or exceed the nominal internal area associated with the pipe size of the SRV inlet. The pressure drop from the vessel to the SRV shall not exceed 3% of the valve's set pressure, when flowing at full capacity.

Ensure the flange and sealing faces of the valve and connective piping are free from dirt, sediment, and scale.

Ensure all flange bolts are drawn evenly to prevent distortion of the valve body and the inlet nozzle.

Position SRVs for easy access and/or removal so that servicing can be properly performed. Ensure sufficient working space is provided around and above the valve.

⚠ DANGER

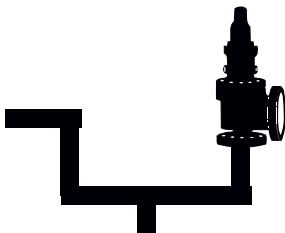

Do not mount valve at the end of pipe through which there is normally no flow or near elbows, tees, bends, etc.

B. Inlet Piping

The inlet piping (see Figure 11) to the valve should be short and directly from the vessel or equipment being protected. The radius of the connection to the vessel should permit smooth flow to the valve. Avoid sharp corners. If this is not practical, then the inlet should be at least one additional pipe diameter larger.

The pressure drop from the vessel to the valve shall not exceed 3% of valve set pressure when the valve is allowing full capacity flow. The inlet piping should never be smaller in diameter than the inlet connection of the valve. Excessive pressure drop in gas, vapor, or flashing-liquid service at the inlet of the SRV will cause the extremely rapid opening and closing of the valve, which is known as "chattering." Chattering will result in lowered capacity and damage to the seating surfaces. The most desirable installation is that in which the nominal size of the inlet piping is the same as, or greater than, the nominal size of the valve inlet flange and in which the length does not exceed the face-to-face dimensions of a standard tee of the required pressure class.

Do not locate SRV inlets where excessive turbulence is present, such as near elbows, tees, bends, orifice plates or throttling valves.

Section VIII of the ASME Boiler and Pressure Vessel Code requires the inlet connection design to consider stress conditions during valve operation, caused by external loading, vibration, and loads due to thermal expansion of the discharge piping.

The determination of reaction forces during valve discharge is the responsibility of the vessel and/or piping designer. GE publishes certain technical information about reaction forces under various fluid flow conditions, but assumes no liability for the calculations and design of the inlet piping.

External loading, by poorly designed discharge piping and support systems, and forced alignment of discharge piping can cause excessive stresses and distortions in the valve as well as the inlet piping. The stresses in the valve may cause a malfunction or leak. Therefore, discharge piping must be independently supported and carefully aligned.

Vibrations in the inlet piping systems may cause valve seat leakage and/or fatigue failure. These vibrations may cause the disc seat to slide back and forth across the

⚠ CAUTION



Heed all service manual warnings. Read installation instructions before installing valve(s).

XI. Recommended Installation Practices (Contd.)

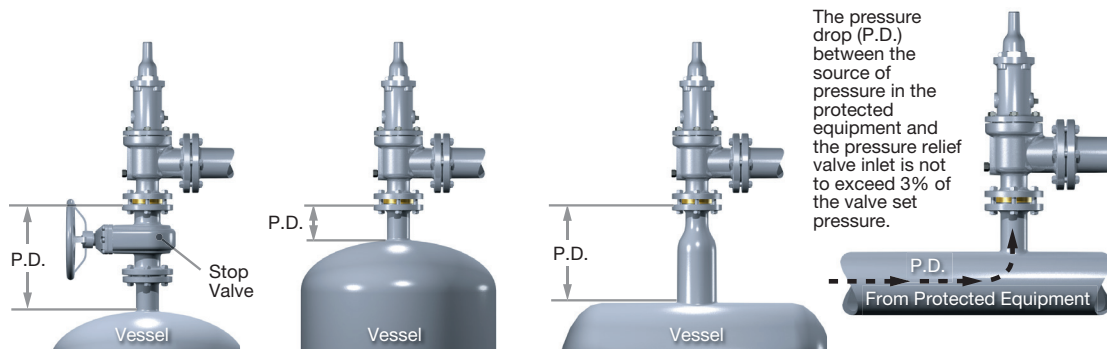

Figure 11: Pressure Drop on the Inlet Piping

nozzle seat and may result in damage to the seating surfaces. Also, vibration may cause separation of the seating surfaces and premature wear to valve parts. High-frequency vibrations are more detrimental to SRV tightness than low-frequency vibrations. This effect can be minimized by providing a larger difference between the operating pressure of the system and the set pressure of the valve, particularly under high frequency conditions.

Temperature changes in the discharge piping may be caused by fluid flowing from the discharge of the valve or by prolonged exposure to the sun or heat radiated from nearby equipment. A change in the discharge piping temperature will cause a change in the length of the piping, which may cause stresses to be transmitted to the SRV and its inlet piping. Proper support, anchoring or provision for flexibility of the discharge piping can prevent stresses caused by thermal changes. Do not use fixed supports.

A continual oscillation of the discharge piping (wind loads) may induce stress distortion in the valve body. The resultant movement of the valve's internal parts may cause leakage.

Where possible, use properly supported drainage piping to prevent the collection of water or corrosive liquid in the valve body.

When two or more valves are piped to discharge into a common header, the built-up backpressure resulting from the opening of one (or more) valve(s) may cause a superimposed backpressure in the remaining valves. Under these conditions, the use of bellows valves is recommended. The use of bellows valves may also permit the use of a smaller-size manifold.

In every case, the nominal discharge pipe size should be at least as large as the nominal size of the SRV outlet flange. In the case of long discharge piping, the nominal discharge pipe size must sometimes be much larger.

C. Outlet Piping

Alignment of the internal parts of the SRV is important to ensure proper operation (see Figure 12). Although the valve body will withstand a considerable mechanical load, unsupported discharge piping consisting of more than a companion flange, long-radius elbow, and a short vertical pipe is not recommended. Use spring supports to connect outlet piping to prevent thermal expansion from creating strains on the valve. The discharge piping should be designed to allow for vessel expansion as well as expansion of the discharge pipe itself. This is particularly important on long distance lines.

ATTENTION!

All non-bellows valves should have a bonnet plug installed. Bellows valves must have an open bonnet vent.

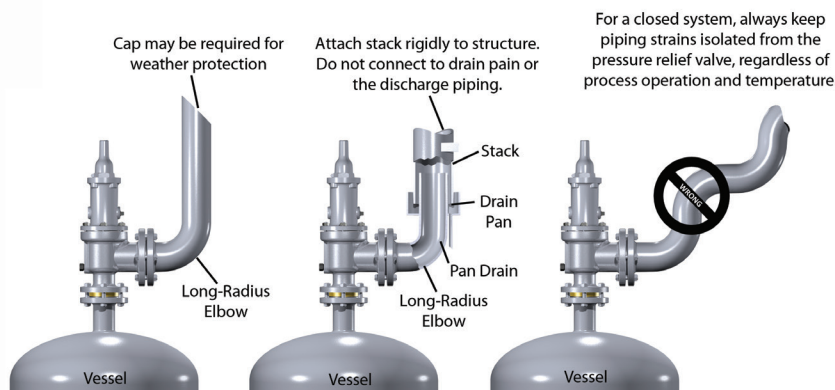

Figure 12: SRV Parts Alignment

XII. Disassembly of 1900 Series Safety Relief Valves

A. General Information

Consolidated SRVs can be easily disassembled for inspection, the reconditioning of seats or the replacement of internal parts. Appropriate set pressure can be established after reassembly. (See Figures 1 through 10 for parts nomenclature.)

ATTENTION!

Do not interchange parts from one valve with parts from another valve.

B. SRV Disassembly

1. If equipped, remove the lifting lever gear as follows:
 - Plain Lever (see Figure 4)
 - Remove cotter pin, lever pin and plain lever [one-piece design] or top lever [two-piece design].
 - Packed Lever (see Figure 3)
 - Disassembly not required. Rotate lever counterclockwise, positioning lifting fork so that it clears release nut during cap removal.
2. Remove the cap.
3. Remove the cap gasket (27), if applicable.
4. Remove adjusting ring pin (4) and adjusting ring pin gasket (5).
5. If the existing blowdown is to be restored upon reassembly, determine the position of the adjusting ring (3) with respect to the disc holder (8) as follows:
 - Turn the adjusting ring counterclockwise (move notches on the adjusting ring from left to right).
 - Record the number of notches that pass the ring pinhole before the ring contacts the disc holder.

ATTENTION!

This procedure does not substitute for actual pressure testing.

CAUTION



Wear necessary protective equipment to prevent possible injury

CAUTION

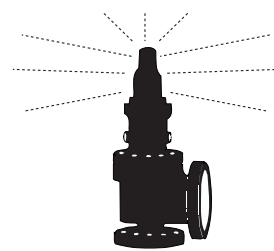

Valve caps and bonnets can trap fluids. Use caution when removing to prevent injury or environmental damage.

DANGER



Before disassembling the valve, ensure there is no media pressure in the vessel.

DANGER



Many pressure vessels protected by Consolidated Safety Relief Valves contain dangerous materials. Decontaminate and clean the valve inlet, outlet, and all external surfaces in accordance with the cleaning and decontaminating recommendations in the appropriate Material Safety Data Sheet.

XII. Disassembly of 1900 Series Safety Relief Valves (Contd.)

6. Follow the procedure appropriate to the orifice valve type:
 - Using a depth micrometer or a dial caliper, measure the distance from the top of the spindle (15) to the top of the adjusting screw (19). This allows the adjusting screw to be readjusted close to the proper spring compression without excessive testing.
 - Record the measurement for reference when reassembling the valve.
 - D through U orifice valves:
 - Loosen the adjusting screw locknut (20).
 - Remove the adjusting screw from the bonnet (11). Use pliers to prevent the spindle from turning when removing the adjusting screw.
 - V and W orifice valves:
 - Attach the setting device (see Figure 13).

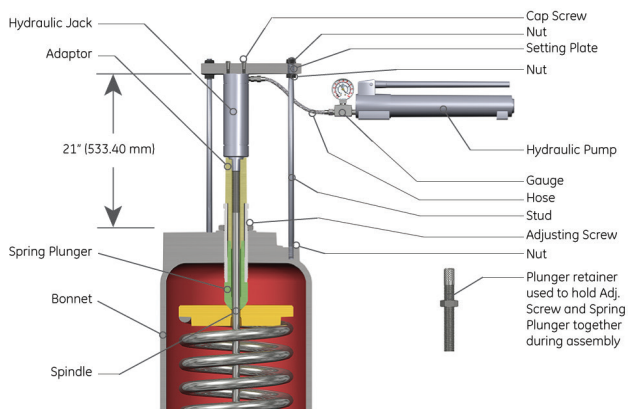

Figure 13: Setting Device for V and W Orifice

- Apply enough pressure to the plunger using the ram to free the adjusting screw.
- Loosen the adjusting screw locknut.
- Completely unscrew the adjusting screw from the bonnet.

7. Remove the stud nuts (14) and lift off the bonnet (11).

ATTENTION!

Set the valve using the setting procedures after reassembly

8. Remove the bonnet gasket (12).

9. Remove the spring (18) and the spring washers (17). Keep the spring and spring washers together as a unit, at all times.
10. Follow the procedure appropriate to the valve type:
 - D through L orifice valves:
 - Remove the upper internal parts by carefully pulling “straight up” on the spindle (15). For bellows valves, take care to avoid damaging the bellows or its flange. If parts are fouled use a suitable solvent for loosening the components.
 - Clamp the skirt portion of the disc holder (8) snugly between two wooden V-blocks in a suitable vise.
 - Compress the spindle retainer (16) with a screwdriver or similar tool through the slots provided and remove the spindle.
 - M through U orifice valves:

ATTENTION!

Special lifting tools are available for ease of upper internal part removal

- Use a screwdriver to compress the spindle retainer (16).
- Remove the spindle (15).
- Insert the lifting tool (see Figure 14) into the disc holder spindle pocket and tighten the eyebolt.
- Remove the disc holder (8) and disc (6) by lifting up on the lifting tool.
- Valve V and W orifice valve:
 - Use the lifting lugs to lift the disc holder (8) and to remove all internals (see Figure 14).

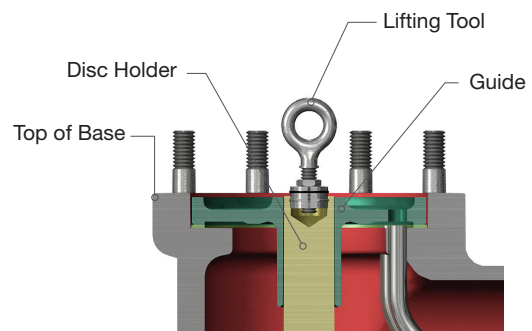

Figure 14: Lifting Tools for M through U Orifice Valves

XII. Disassembly of 1900 Series Safety Relief Valves (Contd.)

ATTENTION!

The bellows convolutions (see Figure 15) are very thin and fragile. Take care to protect them from damage.

11. Remove the guide (9) from the disc holder (8). (For restricted lift valves, see Checking Lift on Restricted Lift Valves.) For V and W orifice unbolt the bellows from guide before guide removal.
12. For D through U orifice bellows valves (see Figure 7), the bellows is attached to the disc holder (8) by right-hand threads. Use a special spanner wrench on the bellows ring to remove it by turning counterclockwise (see Figure 15).
13. Remove the bellows gasket. For V and W orifice bellows valves (see Figure 9), the bellows is bolted to the disc holder (8). Remove these bolts to disassemble the bellows from the disc holder.

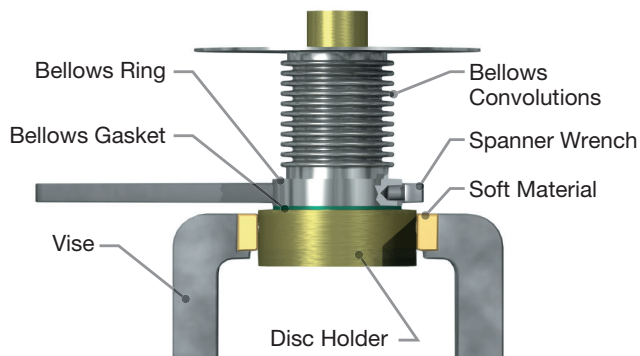

Figure 15: Removing the Bellows Ring

14. Follow the procedure appropriate to the orifice valve type:
 - For D through U orifice valves (see Figure 7), remove the disc (6) from the disc holder (8) as follows:
 - Grasp disc holder by the stem portion, disc end down, and firmly strike down onto a clean, wood surface. Disc should dislodge from disc holder.

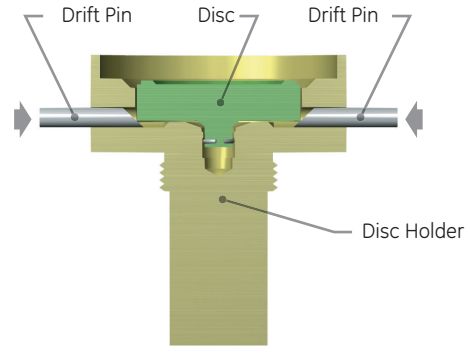

Figure 16: Removing the Disc with Drift Pins

- If disc did not dislodge from disc holder, then clamp the stem portion of the disc holder, disc end up, firmly between two wooden V-blocks in a vise.
- Start inserting special drift pins into the holes in the disc holder (see Figure 16) with the tapered portion of the pins working against the top of the disc, as indicated.
- Use a light machinist hammer to tap each pin alternately until the disc snaps out of the recess in the disc holder.
- For V and W orifice valves (see Figure 9), remove the disc from the disc holder as follows:
 - Turn the disc holder on its side
 - Remove the retaining bolts (7)
 - Attach the lifting lug to the disc and lift out
 - Inspect guide rings (48) for wear and replace if necessary.

15. For O-ring seat seal and universal media soft-seal valves only (See Figures 10a, 10b & 10c), remove the retainer lock screw (s), retainer, and O-ring or Teflon™ seal.
16. Remove the adjusting ring (3) by turning it counterclockwise (from left to right).

ATTENTION!

The nozzle (2) is normally removed for routine maintenance and service.

XII. Disassembly of 1900 Series Safety Relief Valves (Contd.)

17. The nozzle (2) is threaded onto the base (1) and is removed by turning it counterclockwise (from right to left). Before removing the nozzle, soak the threaded joint with a suitable penetrating liquid or solvent. If the nozzle is frozen to the base, apply dry ice or other cooling medium to the inside of the nozzle and heat the base from the outside with a blowtorch in the area of the nozzle threads.

ATTENTION!

Should heat be applied, use care to prevent cracking of cast parts.

18. Using a three- or four-jaw chuck welded vertically to a stand bolted to a concrete floor, clamp the nozzle (2) into the chuck and break the body loose with a heavy rod or pipe (see Figure 17).

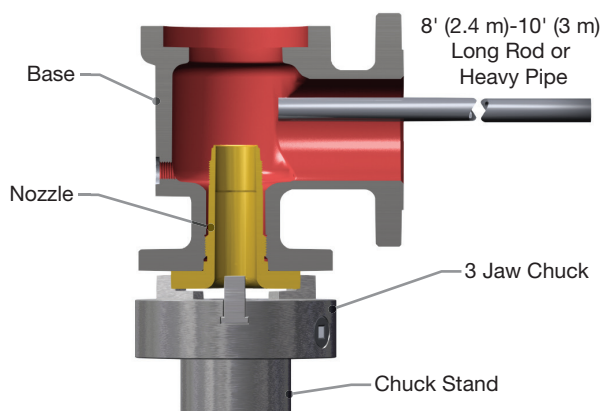

Figure 17: Loosening the Nozzle from the Base

ATTENTION!

Exercise care when inserting a rod or pipe in the outlet. Ensure the valve nozzle is not damaged during the operation.

19. Use a large pipe wrench on the nozzle flange to remove the nozzle (2) from the base (1) (see Figure 18).

View From Top

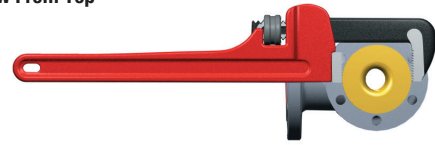

View From Side

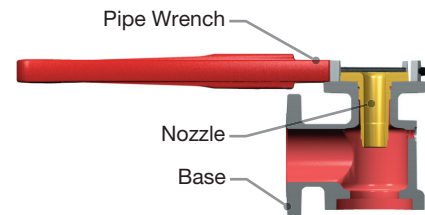

Figure 18: Removing the Nozzle from the Base

C. Cleaning

1900 Series SRV internal parts may be cleaned with industrial solvents, cleaning solutions, and wire brushes. If cleaning solvents are used, take precautions to protect yourself from potential danger from fume inhalation, chemical burns, or explosion. See the solvent's Material Safety Data Sheet (MSDS) for safe handling recommendations and equipment.

⚠ DANGER



Follow recommendations for safe handling in the solvent's Material Safety Data Sheet and observe safe practices for any cleaning method.

Do not sandblast internal parts because it can reduce the dimensions of the parts. The base (1), bonnet (11), and screwed cap (21) may be sandblasted, but take care not to erode internal surfaces or damage machined surfaces.

XIII. Maintenance Instructions

A. General Information

After the valve has been disassembled, closely inspect the seating surfaces. Usually, a lapping of seats is all that is necessary to return a valve to working order. If an inspection shows badly damaged valve seating surfaces, machining will be required before lapping. O-ring seat seal valve nozzles can only be reconditioned by machining, not lapping. (For specific information concerning the machining of nozzle and disc seating surfaces, see the Re-Machining Nozzle Seats and Bores and Re-Machining the Disc Seat sections.)

ATTENTION!

See Optional Glide-Aloy™ Parts to determine if the valve contains Glide-Aloy™ treated components (i.e., the disc holder and/or the guide). Coding on the valve nameplate identifies these components.

The seating surfaces of the metal-seated Consolidated SRV are flat. The nozzle seat is relieved by a 5° angle on the outside of the flat seat. The disc seat is wider than the nozzle seat; thus, the control of seat width is the nozzle seat (see Figure 19).

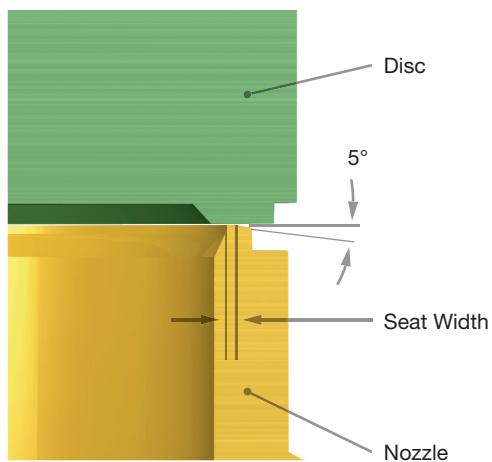

Figure 19: Seating Surface

A cast iron lap, coated with a lapping compound, is used for reconditioning the seating surfaces of the nozzle (2) and disc (6).

ATTENTION!

To establish leak-free valve seats, the nozzle seating surface and the disc seating surface must be lapped flat.

B. Lapping Nozzle Seats (Non-O-Ring Styles)

ATTENTION!

Nozzle laps (See Figure 20) are available from GE. Do not use these laps if the valve nozzle can be removed and machined to the proper seat dimensions (see Tables 1a and 1c).

Lap the 5° angle of the nozzle first (see Figure 20, View A). Then, invert the nozzle lap and use the flat side as a “starter” lap to ensure the seat is square (see Figure 20, View B). Use a ring lap in a circular motion to finish lapping see Figure 20, View C and Reconditioning of Laps (Figure 22 in Section XIII.G). Keep the lap squarely on the flat surface and avoid rocking it. Rocking will cause rounding of the seat.

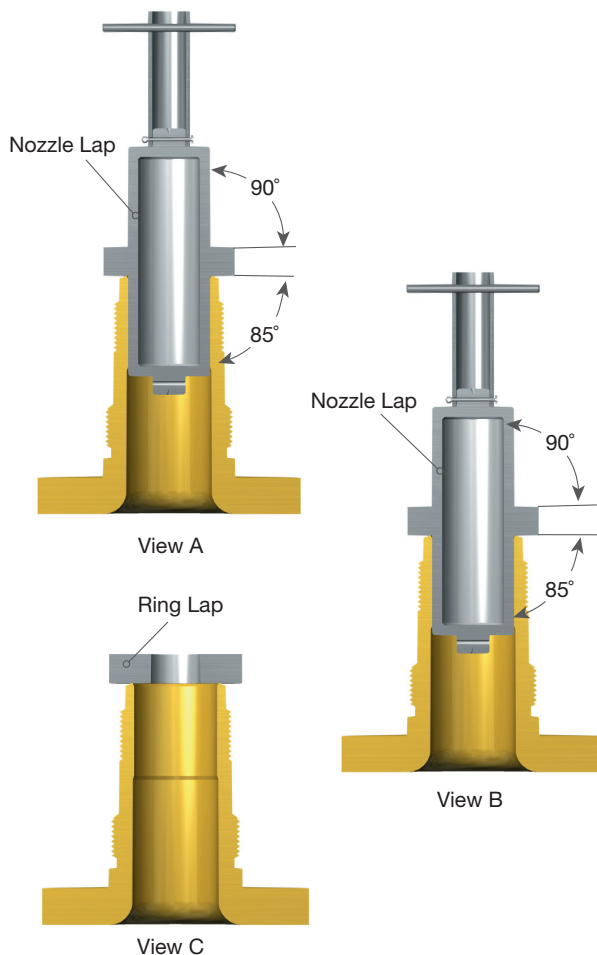

Figure 20: Lapping Nozzle Seats

XIII. Maintenance Instructions (Contd.)

C. Lapped Nozzle Seat Widths

A wide nozzle seat will induce simmer, especially in the smaller-orifice, lower-pressure valves. For this reason, the seats of valves other than O-ring valves should be as narrow as is practical. Since the seat must be wide enough to carry the bearing load imposed upon it by the spring force, the higher-pressure valves must have wider seats than the lower-pressure valves. The nozzle seat width should conform to the measurements in Tables 1a to 1c.

To measure the seat width, use a Model S1-34-35-37 Bausch and Lomb Optical Co. measuring magnifier or an equivalent seven-power glass with a .750" (19.05 mm) scale showing graduations of .005 inch (0.13 mm). Figures 21a and 21b illustrate the use of this tool in measuring the nozzle seat width.

If additional lighting is required for measuring, use a gooseneck flashlight similar to the Type A Lamp Assembly (Standard Molding Corp.), or equivalent.

Table 1a: Nozzle Seat Width (Standard Metal Seat Design)				
Orifice	Set Pressure Range		Lapped Seat Width	
	psig	barg	in.	mm
D-G	1 - 50	0.06 - 3.44	.012 - .015	0.30 - 0.38
	51 - 100	3.51 - 6.89	.015 - .022	0.38 - 0.55
	101 - 250	6.96 - 17.23	.022 - .028	0.55 - 0.71
	251 - 400	17.30 - 27.57	.028 - .035	0.71 - 0.88
	401 - 800	27.64 - 55.15	.035 - .042	0.88 - 1.06
	801 - Above	55.22 - Above	.042 + .005 per 100 psig (.070 ± .005 max)	1.06 + .12 per 6.89 barg (1.77 ± 0.12 max)
H-J	1 - 50	0.06 - 3.44	.019 - .022	0.48 - 0.55
	51 - 100	3.51 - 6.89	.022 - .027	0.55 - 0.68
	101 - 250	6.96 - 17.23	.027 - .031	0.68 - 0.78
	251 - 400	17.30 - 27.57	.031 - .035	0.78 - 0.88
	401 - 800	27.64 - 55.15	.035 - .040	0.88 - 1.01
	801 - Above	55.22 - Above	.040 + .005 per 100 psig (.070 ± .005 max)	1.06 + 0.12 per 6.89 barg (1.77 ± 0.12 max)
K-N	1 - 50	0.06 - 3.44	.025 - .028	0.63 - 0.71
	51 - 100	3.51 - 6.89	.028 - .033	0.71 - 0.83
	101 - 250	6.96 - 17.23	.033 - .038	0.83 - 0.96
	251 - 400	17.30 - 27.57	.038 - .043	0.96 - 1.09
	401 - 800	27.64 - 55.15	.043 - .048	1.09 - 1.21
	801 - Above	55.22 - Above	.048 + .005 per 100 psig (.070 ± .005 max)	1.06 + 0.12 per 6.89 barg (1.77 ± 0.12 max)
P-R	1 - 50	0.06 - 3.44	.030 - .034	0.76 - 0.86
	51 - 100	3.51 - 6.89	.034 - .041	0.86 - 1.04
	101 - 251	6.96 - 17.3	.041 - .049	1.04 - 1.24
	251 - 400	17.30 - 27.57	.049 - .056	1.24 - 1.42
	401 - 800	27.64 - 55.15	.056 - .062	1.42 - 1.57
	801 - Above	55.22 - Above	.062 - .064	1.57 - 1.62
T	1 - 50	0.06 - 3.44	.040 - .043	1.01 - 1.09
	51 - 100	3.51 - 6.89	.043 - .049	1.09 - 1.24
	101 - 250	6.96 - 17.23	.049 - .057	1.24 - 1.44
	251 - 300	17.30 - 20.68	.057 - .060	1.44 - 1.52
U	1 - 50	0.06 - 3.44	.040 - .043	1.01 - 1.09
	51 - 100	3.51 - 6.89	.043 - .049	1.09 - 1.24
	101 - 250	6.96 - 17.23	.049 - .057	1.24 - 1.44
	251 - 300	17.30 - 20.68	.057 - .060	1.44 - 1.52
V	1 - 50	0.06 - 3.44	.075 - .083	1.90 - 2.10
	51 - 100	3.51 - 6.89	.083 - .103	2.10 - 2.61
	101 - 250	6.96 - 17.23	.103 - .123	2.61 - 3.12
	251 - 300	17.30 - 20.68	.123 - .130	3.12 - 3.30
W	1 - 50	0.06 - 3.44	.100 - .110	2.54 - 2.79
	51 - 100	3.51 - 6.89	.110 - .130	2.79 - 3.30
	101 - 250	6.96 - 17.23	.130 - .150	3.30 - 3.81
	251 - 300	17.30 - 20.68	.150 - .160	3.81 - 4.06

Note 1: + .005" (0.13 mm) per 100 psig (6.89 barg) [.070"(1.78 mm) ± .005"(0.13) max].

XIII. Maintenance Instructions (Contd.)

Table 1b: Nozzle Seat Width (Thermodisc Seat Design)				
Orifice	Set Pressure Range		Lapped Seat Width	
	psig	barg	in.	mm
D-F	1 - 100	0.07 - 6.89	.020 - .030	0.51 - 0.76
	101 - 300	6.96 - 20.68	.035 - .045	0.89 - 1.14
	301 - 800	20.75 - 55.16	.045 - .055	1.14 - 1.40
	801 - Above	55.23 - Above	Full Width ³	Full Width ³
G-J	1 - 100	0.07 - 6.89	.025 - .035	0.64 - 0.89
	101 - 300	6.96 - 20.68	.035 - .045	0.89 - 1.14
	301 - 800	20.75 - 55.16	.045 - .055	1.14 - 1.40
	801 - Above	55.23 - Above	Full Width ³	Full Width ³
K-N	1 - 100	0.07 - 6.89	.035 - .045	0.89 - 1.14
	101 - 300	6.96 - 20.68	.045 - .055	1.14 - 1.40
	301 - 800	20.75 - 55.16	.055 - .065	1.40 - 1.65
	801 - Above	55.23 - Above	Full Width ³	Full Width ³
P-R	1 - 100	0.07 - 6.89	.040 - .050	1.02 - 1.27
	101 - 130	6.96 - 8.96	.050 - 0.065	1.27 - 1.65
	131 - 800	9.03 - 55.16	.060 - .070	1.52 - 1.78
	801 - Above	55.23 - Above	Full Width ³	Full Width ³
T	1 - 100	0.07 - 6.89	.050 - .065	1.27 - 1.65
	101 - 300	6.96 - 20.68	.060 - .075	1.52 - 1.91
U	1 - 100	0.07 - 6.89	.050 - .065	1.27 - 1.65
	101 - 300	6.96 - 20.68	.060 - .075	1.52 - 1.91
V	1 - 100	0.07 - 6.89	.075 - .100	1.52 - 2.54
	101 - 300	6.96 - 20.68	.100 - .130	2.54 - 3.30
W	1 - 100	0.07 - 6.89	.100 - .125	2.54 - 3.18
	101 - 300	6.96 - 20.68	.120 - .160	3.05 - 4.06

Note 3: Not to exceed .070"(1.78 mm) ± .005"(0.13).

Table 1c: Nozzle Seat Width (UM Metal Seat Design)					
Orifice	Set Pressure Range		Lapped Seat Width		
	psig	barg	in.	+/- .005 .000	mm +/- .127 .000
D-G	To 50	To 3.44	0.012		0.30
	51 - 100	3.51 - 3.89	0.018		0.45
	101 - 250	6.96 - 17.23	0.025		0.63
	251 - 400	17.30 - 27.57	0.032		0.81
	401 and Above	27.64 and Above	0.038		0.97
H - J	To 50	To 3.44	0.019		0.48
	51 - 100	3.51 - 6.89	0.025		0.63
	101 - 250	6.96 - 17.23	0.029		0.73
	251 - 400	17.30 - 27.57	0.032		0.81
	401 - 800	27.64 - 55.15	0.038		0.97
	801 + add 0.005 inch/100 psi	55.22 + add 0.12 mm/7 bar	0.038 - 0.070 Max		0.97 - 1.77 Max
K - N	To 50	To 3.44	0.025		0.63
	51 - 100	3.51 - 6.89	0.030		0.76
	101 - 250	6.96 - 17.23	0.035		0.88
	251 - 400	17.30 - 27.57	0.040		1.01
	401 - 800	27.64 - 55.15	0.045		1.14
	801 + add 0.005 inch/100 psi	55.22 + add 0.12 mm/7 bar	0.045 - 0.070 Max		1.14 - 1.77 Max
P - R	To 50	To 3.44	0.030		0.76
	51 - 100	3.51 - 6.89	0.037		0.93
	101 - 250	6.96 - 17.23	0.045		1.14
	251 - 400	17.30 - 27.57	0.052		1.32
	401 - 800	27.64 - 55.15	0.059		1.49
	801 +	55.2 +	0.064		1.62
T - U	To 50	To 3.44	0.040		1.01
	51 - 100	3.51 - 3.89	0.045		1.14
	101 - 250	6.96 - 17.23	0.053		1.34
	251 - 300	17.30 - 20.68	0.060		1.52
V	To 50	To 3.44	0.075		1.90
	51 - 100	3.51 - 3.89	0.095		2.41
	101 - 250	6.96 - 17.23	0.115		3.92
	251 - 300	17.30 - 20.68	0.130		3.30
W	To 50	To 3.44	0.100		2.54
	51 - 100	3.51 - 3.89	0.120		3.04
	101 - 250	6.96 - 17.23	0.140		3.55
	251 - 300	17.30 - 20.68	0.160		4.06

XIII. Maintenance Instructions (Contd.)

Table 1d: Nozzle Seat Width (Standard Soft Seat Design (UM))

Orifice	Set Pressure Range		Lapped Seat Width	
	psig	barg	in.	mm
F-H	1 - 124	0.07 - 8.55	.010	0.25
	125 - 359	8.62 - 24.75	No Lapping, Sharp Angle	
	360 - 749	24.82 - 51.64	.005	0.13
	750 - Above	51.71 - Above	.010	0.25
J-L	1 - 124	0.07 - 8.55	.015	0.38
	125 - 359	8.62 - 24.75	No Lapping, Sharp Angle	
	360 - 749	24.82 - 51.64	.010	0.25
	750 - Above	51.71 - Above	.015	0.38
M-P	1 - 124	0.07 - 8.55	.025	0.64
	125 - 359	8.62 - 24.75	.005	0.13
	360 - 749	24.82 - 51.64	.018	0.46
	750 - Above	51.71 - Above	.050	1.27
Q-R	1 - 124	0.07 - 8.55	.072	1.83
	125 - 200	8.62 - 13.79	.013	0.33
	201 - 360	13.86 - 24.82	.025	0.64
T-U	1 - 124	0.07 - 8.55	.072	1.83
	125 - 200	8.62 - 13.79	.013	0.33
	201 - 360	13.86 - 24.82	.025	0.64
V-W	1 - 124	0.07 - 8.55	.100	2.54
	125 - 200	8.62 - 13.79	.017	0.43
	201 - 300	13.86 - 20.68	.025	0.64

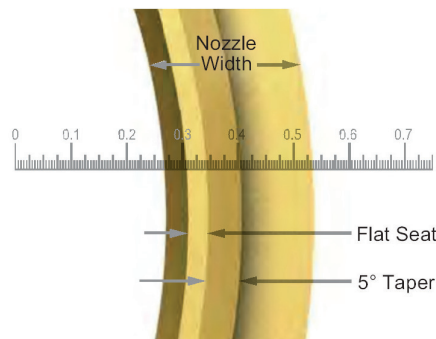

Figure 21b: Measuring Magnifier Detail

D. Lapping Disc Seats

Use a ring lap or lapping plate to lap the disc in a circular motion, applying uniform pressure and slowly rotating the disc or lap.

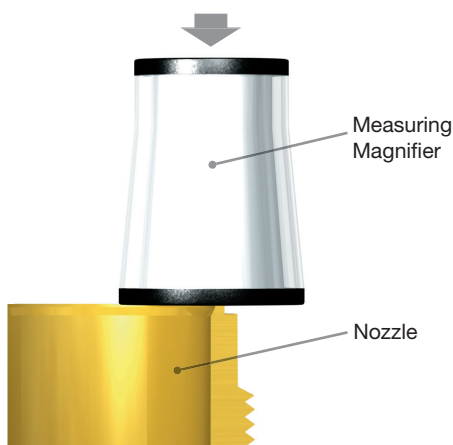

Figure 21a: Measuring Magnifier

E. Precautions and Hints for Lapping Seats

To ensure a quality lapping process, observe precautions and guidelines as follows:

- Keep work materials clean.
- Always use a fresh lap. If signs of wear (out of flatness) are evident, recondition the lap.
- Apply a very thin layer of lapping compound to the lap to prevent rounding off the edges of the seat.
- Keep the lap squarely on the flat surface, and avoid rocking the lap, which causes rounding of the seat.
- When lapping, keep a firm grip on the lapped part to prevent dropping it and damaging the seat.
- Lap in a circular motion while applying a uniform pressure. Slowly rotate the lap to evenly distribute the lapping compound.
- Wipe off the old compound and replace it with new compound frequently. Apply more pressure to speed the cutting action of the compound.
- To check the seating surfaces, remove all compound from the seat and the lap. Then, shine the seat with the same lap using the lapping method as described above. Low sections on the seating surface show up as shadow in contrast to the shiny portion.
- If shadows are present, further lapping is necessary. Only laps known to be flat can be used. It should take only a few minutes to remove the shadows.
- When lapping is complete, any lines appearing as cross-scratches can be removed by rotating the lap on its axis (which has been wiped clean of compound) on the seat.
- Thoroughly clean the lapped seat using a lint free cloth and a cleansing fluid.

XIII. Maintenance Instructions (Contd.)

ATTENTION!

Before assembly, lap the contact surfaces of the nozzle, soft-seat disc (UM DA) and o-ring retainer to provide metal-to-metal seat tightness in the event of O-ring or Teflon™ seal (UM DA) failure.

F. Lapping O-Ring Seating Surfaces

Refer to Figures 10a and 10b and assemble the O-ring retainer to the disc holder (8) (D through J orifice) or disc (6) (K through U orifice) using the retainer lock screw(s) as follows:

1. Apply 3A lapping compound to the retainer seating surface.
2. Place the O-ring retainer on the nozzle seat (see Figure 10a and 10b) and lap the O-ring retainer to the nozzle (2).
3. Once uniform contact is established, clean the nozzle (2) and O-ring retainer.
4. Repeat the procedure with 1000-grit compound.
5. Remove the retainer lock screw(s) and O-ring retainer, and thoroughly clean the O-ring retainer, retainer lock screws, and disc holder (8) or disc (6).

G. Reconditioning of Laps

Ring laps are reconditioned by lapping them on a flat lapping plate in a figure-eight motion (see Figure 22). To ensure the best results, recondition the ring laps after each use. Use an optical flat to check the quality of the lap.

Nozzle laps (see Figure 23) must be re-machined to recondition the lapping surfaces. Place the nozzle lap in a lathe between centers (see Figure 23). The surfaces marked A and B must be running concentrically.

One lapping surface is 90° and the other is 85°. The angle of each surface is marked on the lap. Machine surfaces C and D by taking light cuts at the proper angle until the lapping surfaces are reconditioned.

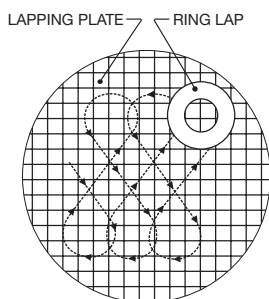

Figure 22: Lapping Pattern

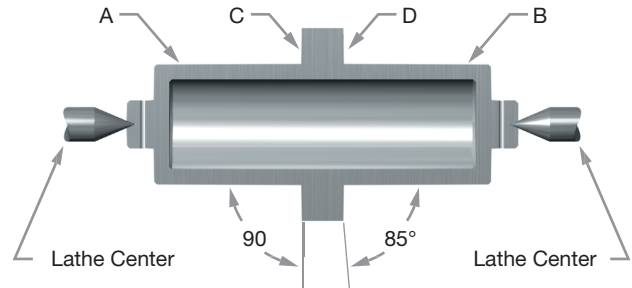

Figure 23: Nozzle Lap in a Lathe

H. Re-Machining Nozzle Seats and Bores

1. Remove the nozzle (2) from the valve to be remachined. If it cannot be removed from the base (1), re-machine it inside the base.
2. Set-up the lathe and nozzle (2) as follows:
 - Grip the nozzle in a four-jaw independent chuck (or collet, if appropriate) using a piece of soft material such as copper or fiber between the jaws and the nozzle (see Figure 24).
 - True-up the nozzle so that the surfaces marked B, C, and D run true within .001" (.025 mm) on the total indicator reading (see Figure 24).

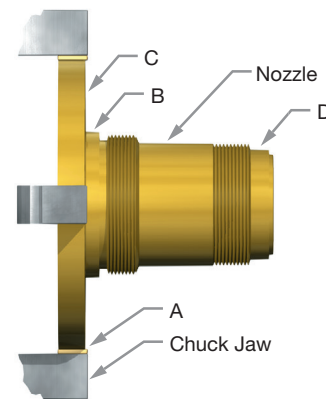

Figure 24: Nozzle Positioned in a Jaw

3. Re-machine the metal-to-metal seat (see Figure 19 and Tables 1a, 1b and 1c) as follows:
 - Make light cuts across the surface L at 5° until the damaged areas are removed. Turn to the smoothest possible finish.
 - Cut back the outside surface at G until dimension N is obtained. The surface at G is common to all nozzles.
 - Re-machine diameter H, until dimension E is obtained. Reestablish angle P.

XIII. Maintenance Instructions (Contd.)

The nozzle is now ready for lapping.

- Discard the nozzle when the minimum dimension D (see Figure 29a, 29b and 29c and Table 3a, 3b, 3c) is reached.
4. Re-machine the o-ring seat seal (see Figure 29b and Table 3b) as follows:
- Make light cuts across surface A at 45° until the damaged areas are removed. Turn to the smoothest possible finish.
 - Cut back the outside surface at M until dimension J is obtained. Re-machine radius B.

I. Re-Machining the Disc Seat

Machine the standard disc seating surface (see Figure 25) as follows:

1. Grip the disc (6) in a four-jaw independent chuck (or collet, if appropriate), using a piece of soft material such as copper or fiber between the jaws and the disc (see Figure 25).
2. True-up the disc (6) so that the surface marked B and C run true within .001" (0.025 mm) on the total indicator reading (see Figure 25).
3. Make light cuts across the seating surface L until damaged areas are removed. Turn to the smoothest possible finish.

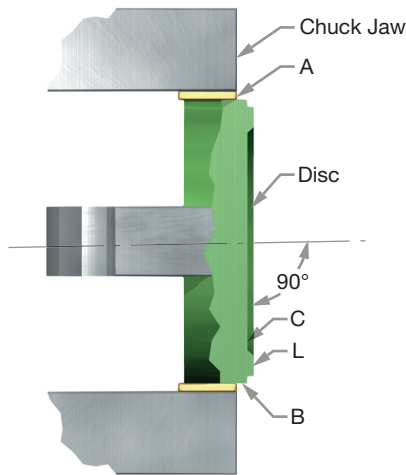

Figure 25: Standard Disc Seating Surface

The disc (6) is now ready for lapping.

- Discard the disc if the minimum dimension N or T (Figures 30a, 30b, 30c and Tables 5a and 5b) is reached. Do not reestablish surface C (see Figure 25).

ATTENTION!

Do not machine a Thermodisc,
o-ring Seat disc, or Soft-seat (UM DA) disc.

J. Checking Spindle Concentricity

It is important that the spindle (15) of an SRV be straight in order to transmit the spring load to the disc (6) without binding laterally. Over-gagging is a common cause of bent spindles. Check the essential working surfaces of the spindle using any of the recommended methods as follows:

1. Set up the V-block support (see Figure 26) as follows:
 - Place the ball-pointed spindles in a piece of material B that has been recessed to permit free rotation of the spindle (15). For hollow spindles, a ball-pointed support is required.
 - Support the spindle with a V-block A placed near the upper end of the spindle, but below the threads.
 - Apply a dial indicator at approximately 45° to the outer edge of the spring washer seat at C.
 - Rotate the spindle. The total indicator reading should not exceed .007" (.17 mm). Straighten the spindle, if necessary. To straighten the spindle, place the unthreaded portion of the small and large end in padded V-blocks, with the point of maximum indicator readout upward, and then apply a downward force with a padded press or jack as required, until the spindle is within the specifications.

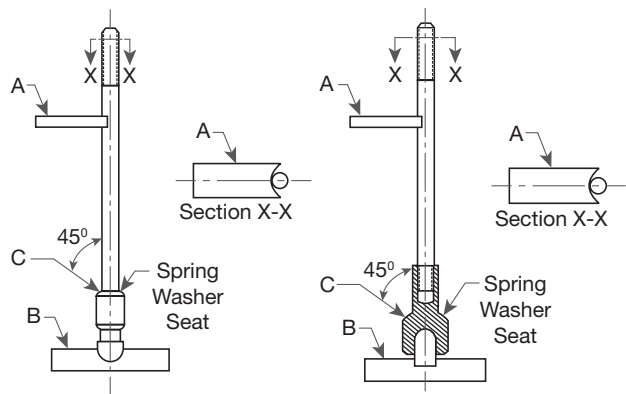

Figure 26: V-Block Support Setup

XIII. Maintenance Instructions (Contd.)

K. Set Pressure Change-Disc Holder

The disc holder (8) must be replaced if the set pressure must be changed and the change involves crossing the dividing line between high pressure and low pressure. Determine whether the disc holder must be changed when changing the set pressure (see Tables 2a and 2b).

Other 1900 Series valves may be restricted in the same manner when necessary. These valves may be restricted to a minimum lift of 30% of the full rated capacity or .080" (2.03 mm).

It is important to check lift on all restricted lift valves after servicing or replacing parts. This procedure is necessary to ensure reliability of the nameplate capacity.

L. Checking Lift on Restricted Lift Valves

ATTENTION!

Restricted lift valves may be identified by the restricted lift value stamped on the nameplate.

General

Restricted lift valves have a limit washer that prevents the disc (6) and disc holder (8) from lifting beyond the required lift and resulting capacity. The D-2 and E-2 valves are naturally a restricted lift valve, as the seat dimensions and bore diameter are identical to the F orifice nozzle. The 1900 UM D and E have components identical to the 1900 F UM, but with limit washers.

ATTENTION!

The required lift for a restricted lift valve is indicated on the valve nameplate (see Figure 27). The minimum certified lift shall be per National Board NB-18 document.

Note: The values to be subtracted from the full lift measurement given in the "Value to be subtracted" chart on page 32 are not in all cases the same as the lift value given in NB-18 document. This is due to accounting for O-ring expansion on O-ring seated valves. Nameplate lift values shall be per NB-18 document.

		Consolidated® Valve <small>Dresser, Inc. Subsidiary of General Electric Company</small>	
		SIZE	
		CRN	
		SERIAL NO	
MANUF		ASSEMBLER	
TYPE			
SET PRESS	CDTP	BACK PRESS	
PRESS UNITS	LIFT		
CAP	CAP UNITS		
MEDIA			

Figure 27: Valve Nameplate
 (Note: Lift value to be obtained from NB-18 document)

XIII. Maintenance Instructions (Contd.)

Table 2a: Disc Holder Selection									
Orifice Size	Air/Gas (Non-Liquid, Non-O-Ring) Low Pressure Disc Holder	Air/Gas (Non-Liquid, Non-O-Ring) High Pressurer Disc Holder	Liquid Service (LS)	Liquid Service OORing (DL or LS-DA)	Air/Gas O-Ring High Pressure (DA)	Air/Gas O-Ring Low Pressurer (DA)	Liquid Service (LA)	Liquid Service O-Ring (LA-DA) High Pressurer	Liquid Service O-Ring (LA-DA) Low Pressure
D-1 Sup-plantd	-	All Pressures	All Pressures	All Pressures	-	All Pressures (Same as "DL" Disc Holder)	All Pressures	N/A	N/A
30D-1 Sup-plantd	-	All Pressures	All Pressures	All Pressures	-	All Pressures (Same as "DL" Disc Holder)	All Pressures	N/A	N/A
E-1 Sup-plantd	100 psig and Below	Above 100 psig	All Pressures	All Pressures	36 psig and Above (Same as "DL" Disc Holder)	5 - 35 psig	All Pressures	N/A	N/A
30E-1 Sup-plantd	100 psig and Below	Above 100 psig	All Pressures	All Pressures	36 psig and Above (Same as "DL" Disc Holder)	5 - 35 psig	All Pressures	N/A	N/A
D - 2 E - 2	100 psig and Below	Above 100 psig	All Pressures (Same as Low Pressure Air/Gas Disc Holder)	All Pressures	36 psig and Above (Same as "DL" Disc Holder)	5 - 35 psig	All Pressures	Above 75 psig	75 psig and Below
30D - 2 30E - 2	100 psig and Below	Above 100 psig	All Pressures (Same as Low Pressure Air/Gas Disc Holder)	All Pressures	36 psig and Above (Same as "DL" Disc Holder)	5 - 35 psig	All Pressures	Above 75 psig	75 psig and Below
F - 1	100 psig and Below	Above 100 psig	All Pressures (Same as Low Pressure Air/Gas Disc Holder)	All Pressures	36 psig and Above (Same as "DL" Disc Holder)	5 - 35 psig	All Pressures	Above 75 psig	75 psig and Below
30F - 1	100 psig and Below	Above 100 psig	All Pressures (Same as Low Pressure Air/Gas Disc Holder)	All Pressures	36 psig and Above (Same as "DL" Disc Holder)	5 - 35 psig	All Pressures	Above 75 psig	75 psig and Below
G - 1	50 psig and Below	Above 50 psig	All Pressures (Same as Low Pressure Air/Gas Disc Holder)	All Pressures	121 psig and Above	5 - 120 psig	All Pressures	All Pressures	-
30G - 1	50 psig and Below	Above 50 psig	All Pressures (Same as Low Pressure Air/Gas Disc Holder)	All Pressures	121 psig and Above	5 - 120 psig	All Pressures	All Pressures	-
H - 1	50 psig and Below	Above 50 psig	All Pressures (Same as Low Pressure Air/Gas Disc Holder)	All Pressures	121 psig and Above	5 - 120 psig	All Pressures	All Pressures	-
30H - 1	50 psig and Below	Above 50 psig	All Pressures (Same as Low Pressure Air/Gas Disc Holder)	All Pressures	121 psig and Above	5 - 120 psig	All Pressures	All Pressures	All Pressures
J - 2	50 psig and Below	Above 50 psig	All Pressures (Same as Low Pressure Air/Gas Disc Holder)	All Pressures	121 psig and Above	5 - 120 psig	All Pressures	All Pressures	All Pressures
K - 1	-	All Pressures	All Pressures	All Pressures	All Pressures	All Pressures	-	All Pressures	All Pressures

Table 2b: Disc Holder Selection Criteria (UM)						
Orifice	Low Pressure Disc Holder		Medium Pressure Disc Holder		High Pressure Disc Holder	
	psig	barg	psig	barg	psig	barg
D-F	50 & below	3.45 & below	51 - 100	3.52 - 6.89	101 and Above	6.96 and Above
G	80 & below	5.52 & below	-	-	81 and Above	5.58 and Above
H	60 & below	4.14 & below	-	-	61 and Above	4.21 and Above
J	40 & below	2.76 & below	-	-	41 and Above	2.83 and Above
K-U	Not Applicable	Not Applicable	-	-	All Pressures	All Pressures
V-W	Not Applicable	Not Applicable	-	-	15 and Above	1.03 and Above

XIII. Maintenance Instructions (Contd.)

M. Determining the Correct Limit Washer Length

Determine the correct limit washer length (see Figure 28) as follows:

1. Assemble the disc (6) and disc holder (8) (installing the bellows gasket and bellows, if applicable) as follows:

ATTENTION!

Do not use an impact wrench on bellows valves.

ATTENTION!

For O-ring seated valves, leave out the O-ring when determining the limit washer length.

- Place the guide over the disc holder barrel and connect the spindle (15) to the disc holder (8).
 - Install the eductor tube (40) in base (1), if applicable.
 - Install the adjusting ring (3) below the seat.
2. Install the guide gasket (10), and insert the disc assembly from Step 1 into the base (1).
 3. Install the bonnet gasket (12) and bonnet (11) (leaving out the spring assembly at this time).
 4. Tighten the stud nuts (14) to compress the bonnet gasket (12).
 5. Place a dial indicator on the bonnet (11) and over the spindle (15) and then zero the indicator. Measure total lift by pushing the disc (6) upward. Subtract the required lift of the valve from the measured lift to find the required limit washer length. Value to be subtracted shall be per chart below.
 6. Machine the limit washer to the required length.
 7. Machine the inside chamfer, deburring and polishing as required.
 8. Disassemble the valve.

9. Install the limit washer with the chamfer down and reassemble the valve as described in Steps 2 through 4.
10. Measure the lift of the valve and compare it with the required lift as given on the NB-18 document (-0.000", +0.005" [-0.000 mm, +0.127 mm]). Take one of the following steps, based on the results, if the lift is not correct:
 - If the actual lift is less than required, machine the limit washer as necessary to obtain the required lift. (Machine chamfer, deburr and polish before installation into the valve.)
 - If the actual lift is greater than required, obtain a new limit washer, and return to Step 7. (Machine chamfer, deburr and polish before installation into valve.)
11. Once correct lift is obtained, disassemble the valve. Install spring assembly and O-ring (if required).

ATTENTION!

Ensure the limit washer has been chamfered to fit over the radius of the disc holder (8). The limit washer must be installed so that the chamfered end is mating to the back face of disc holder.

ATTENTION!

Check all dimension requirements for each valve. Do not interchange internal parts or use a different base after a set of parts has been custom-fit.

ATTENTION!

For bellows Type D and E valves, check the outside diameter and, if necessary, emery cloth down to .680" (17.3 mm) maximum diameter in order to avoid interference with the bellows threads.

Orifice	VALUE TO BE SUBTRACTED					
	STD. 1900 & 1900 TD Steam, Air & Gas	1900 XDA Steam, Air & Gas	1900 Liquid Valves on Liquid Valve Applications			
			XLS	LA	XDL	DALA
D-2	0.066 in.	0.100 in.	0.063 in.	0.056 in.	0.100 in.	0.100 in.
E-2	0.119 in.	0.139 in.	0.100 in.	0.093 in.	0.139 in.	0.139 in.

XIII. Maintenance Instructions (Contd.)

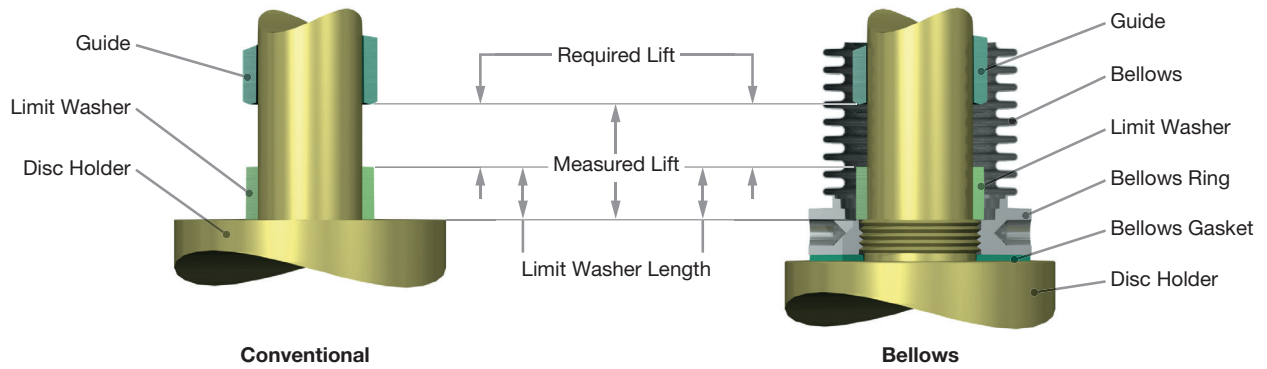

Figure 28: Determining Lift and Limit Washer Length

XIV. Inspection and Part Replacement

A. Nozzle Inspection Criteria

Nozzle should be replaced if:

- Dimension from seat to first thread, after re-machining and lapping, is less than D min. (see Tables 3).
- Threads are damaged from pitting and/or corrosion.
- Top of flange and intersecting surface are damaged from galling and/or tearing.
- Seat width is outside specification and can not be reestablished per Nozzle Dimensions in Table 3a & 3c (see Tables 3a, 3b or 3c).

B. Nozzle Seat Width

Using a measuring magnifying glass (see Lapped Nozzle Seat Widths), determine whether the seating surface must be machined before lapping. If the seat can be lapped flat without exceeding the required seat width (see Tables 1a, 1b or 1c), it does not require machining. To reduce the seat width, the 5° angle surface must be machined and all seat dimensions need to be verified, and reestablished if necessary. The nozzle must be replaced if the D dimension is reduced below the minimum (see Tables 3).

C. Nozzle Bore Inspection

All 1900 Series SRV nozzles manufactured after August 1978 have increased bore diameters. Original and new nozzles are interchangeable, but the rated capacities are different (see Tables 4).

D. 1900 Series SRV Standard Disc Inspection Areas

The standard 1900 Series disc (see Figure 30) can be machined until the N dimension is reduced to its minimum size (see Table 5). The T dimension is provided to ensure the disc has not been machined beyond its limits. If re-machining reduces the thickness of the disc (T min.), the entire disc holder assembly drops with respect to the seating plane of the nozzle. This creates a significant change in the huddle chamber configuration and results in significantly more simmer before opening.

E. 1900 Series Thermodisc* Replacement Criteria

The Thermodisc must be replaced if:

- Seat defects and damage cannot be lapped out without reducing the A dimension below those listed in Table 6 (see Figure 31).

ATTENTION!

Flange thickness changes the center-to-face dimension. Ensure the minimum dimension for orifice D through P is .656" (16.67 mm), and for Q through W is .797" (20.24 mm).

ATTENTION!

The A dimension on orifice D through H is difficult to measure. If the .006" (0.15 mm) minimum thickness of the thermal lip cannot be measured, replace the Thermodisc.

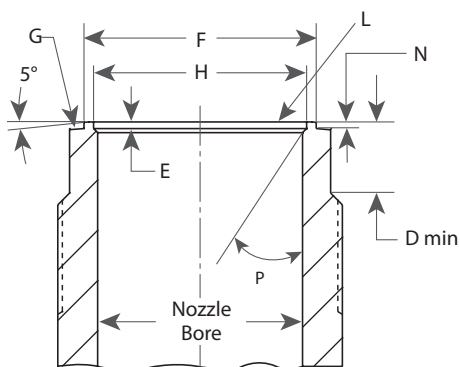

Figure 29a: Metal Seated Nozzle

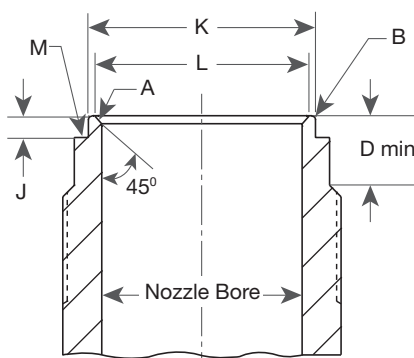

Figure 29b: O-Ring Seal Nozzle

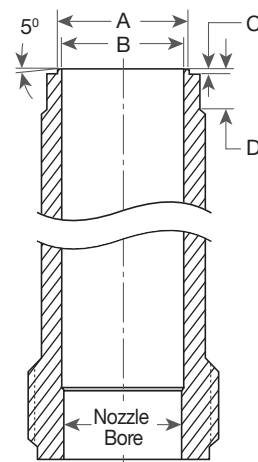

Figure 29c: Soft-Seat O-Ring Nozzle

Figure 29: Metal Seated and O-Ring Nozzles

XIV. Inspection and Part Replacement (Contd.)

Table 3a: Nozzle Machined Dimensions (Metal Seated Nozzle)
English Units: Inch

Nozzle		Metal-To-Metal						O-Ring Seat Seal			
Orifice	D Min.	E ± $\begin{smallmatrix} .005 \\ .000 \end{smallmatrix}$	F ± $\begin{smallmatrix} .005 \\ .000 \end{smallmatrix}$	H ± $\begin{smallmatrix} .005 \\ .000 \end{smallmatrix}$	N ± $\begin{smallmatrix} .005 \\ .000 \end{smallmatrix}$	P ± 1/2°	Radius B ± $\begin{smallmatrix} .005 \\ .000 \end{smallmatrix}$	J ± $\begin{smallmatrix} .005 \\ .000 \end{smallmatrix}$	K	L Max.	
D-1	13/32	0.015	-	0.518	-	30°	0.015	0.062	0.573	$\begin{smallmatrix} +.000 \\ -.002 \end{smallmatrix}$	0.537
E-1	15/32	0.020	0.788	0.686	0.025	30°	0.015	0.060	0.733	$\begin{smallmatrix} +.000 \\ -.002 \end{smallmatrix}$	0.688
D-2, E-2, F	5/16	0.030	0.955	0.832	0.035	30°	0.015	0.079	0.868	$\begin{smallmatrix} +.000 \\ -.003 \end{smallmatrix}$	0.814
G	5/16	0.035	1.094	0.954	0.035	30°	0.021	0.090	1.060	$\begin{smallmatrix} +.000 \\ -.003 \end{smallmatrix}$	0.999
H	1/4	0.035	1.225	1.124	0.035	45°	0.021	0.060	1.216	$\begin{smallmatrix} +.000 \\ -.003 \end{smallmatrix}$	1.167
J	3/8	0.035	1.546	1.436	0.035	45°	0.021	0.074	1.534	$\begin{smallmatrix} +.000 \\ -.003 \end{smallmatrix}$	1.481
K	7/16	0.063	1.836	1.711	0.063	45°	0.021	0.126	1.838	$\begin{smallmatrix} +.000 \\ -.004 \end{smallmatrix}$	1.781
L	7/16	0.063	2.257	2.132	0.063	45°	0.016	0.126	2.208	$\begin{smallmatrix} +.000 \\ -.004 \end{smallmatrix}$	2.158
M	7/16	0.063	2.525	2.400	0.063	45°	0.021	0.126	2.536	$\begin{smallmatrix} +.000 \\ -.004 \end{smallmatrix}$	2.480
N	1/2	0.063	2.777	2.627	0.063	45°	0.021	0.101	2.708	$\begin{smallmatrix} +.000 \\ -.004 \end{smallmatrix}$	2.652
P	5/8	0.093	3.332	3.182	0.093	45°	0.021	0.150	3.334	$\begin{smallmatrix} +.000 \\ -.004 \end{smallmatrix}$	3.279
Q	7/8	0.093	4.335	4.185	0.093	45°	0.021	0.188	4.338	$\begin{smallmatrix} +.000 \\ -.006 \end{smallmatrix}$	4.234
R	1	0.093	5.110	4.960	0.093	45°	0.021	0.215	5.095	$\begin{smallmatrix} +.000 \\ -.006 \end{smallmatrix}$	5.036
T	3/4	-	6.234	6.040	0.093	-	0.021	0.142	6.237	$\begin{smallmatrix} +.000 \\ -.007 \end{smallmatrix}$	6.174
W	1 3/4	0.350	11.058	10.485	0.348	30°	-	-	-	-	-

Table 3b: Nozzle Machined Dimensions (O-Ring Seat Nozzle)
Metric Units: mm

Nozzle		Metal-To-Metal						O-Ring Seat Seal			
Orifice	D Min.	E ± $\begin{smallmatrix} .127 \\ .000 \end{smallmatrix}$	F ± $\begin{smallmatrix} .127 \\ .000 \end{smallmatrix}$	H ± $\begin{smallmatrix} .127 \\ .000 \end{smallmatrix}$	N ± $\begin{smallmatrix} .127 \\ .000 \end{smallmatrix}$	P ± 1/2°	Radius B ± $\begin{smallmatrix} .127 \\ .000 \end{smallmatrix}$	J ± $\begin{smallmatrix} .127 \\ .000 \end{smallmatrix}$	K	L Max.	
D-1	10.3	0.38	-	13.16	-	30°	0.38	1.57	14.55	$\begin{smallmatrix} +.000 \\ -.051 \end{smallmatrix}$	13.64
E-1	11.9	0.51	20.01	17.43	0.64	30°	0.38	1.52	18.62	$\begin{smallmatrix} +.000 \\ -.051 \end{smallmatrix}$	17.47
D-2, E-2, F	7.9	0.76	24.26	21.13	0.89	30°	0.38	2.01	22.05	$\begin{smallmatrix} +.000 \\ -.076 \end{smallmatrix}$	20.68
G	7.9	0.89	27.79	24.24	0.89	30°	0.53	2.29	26.92	$\begin{smallmatrix} +.000 \\ -.076 \end{smallmatrix}$	25.37
H	6.3	0.89	31.12	28.55	0.89	45°	0.53	1.52	30.89	$\begin{smallmatrix} +.000 \\ -.076 \end{smallmatrix}$	29.64
J	9.5	0.89	39.27	36.47	0.89	45°	0.53	1.88	38.96	$\begin{smallmatrix} +.000 \\ -.076 \end{smallmatrix}$	37.62
K	11.1	1.60	46.63	43.46	1.60	45°	0.53	3.20	46.69	$\begin{smallmatrix} +.000 \\ -.10 \end{smallmatrix}$	45.24
L	11.1	1.60	57.33	54.15	1.60	45°	0.41	3.20	56.08	$\begin{smallmatrix} +.000 \\ -.10 \end{smallmatrix}$	54.81
M	11.1	1.60	64.14	60.96	1.60	45°	0.53	3.20	64.41	$\begin{smallmatrix} +.000 \\ -.10 \end{smallmatrix}$	62.99
N	12.7	1.60	70.54	66.73	1.60	45°	0.53	2.57	68.78	$\begin{smallmatrix} +.000 \\ -.10 \end{smallmatrix}$	65.07
P	15.9	2.36	84.63	80.82	2.36	45°	0.53	3.81	84.68	$\begin{smallmatrix} +.000 \\ -.10 \end{smallmatrix}$	83.28
Q	22.2	2.36	110.11	106.30	2.36	45°	0.53	4.78	110.19	$\begin{smallmatrix} +.000 \\ -.152 \end{smallmatrix}$	107.54
R	25.4	2.36	129.79	125.98	2.36	45°	0.53	5.46	129.41	$\begin{smallmatrix} +.000 \\ -.152 \end{smallmatrix}$	127.92
T	19.0	-	158.34	153.42	2.36	-	0.53	3.61	158.42	$\begin{smallmatrix} +.000 \\ -.178 \end{smallmatrix}$	156.82
W	44.5	8.89	280.90	266.30	8.84	30°	-	-	-	-	-

XIV. Inspection and Part Replacement (Contd.)

Table 3c: Nozzle Machined Dimensions (UM Soft-Seat Nozzle)

Orifice	D min.		A		B		C	
	in.	mm	in.	mm	in.	mm	in.	mm
D	.313	7.95	.906	23.01	.831	21.11	.026	0.66
E	.313	7.95	.906	23.01	.831	21.11	.026	0.66
F	.313	7.95	.906	23.01	.831	21.11	.026	0.66
G	.313	7.95	1.039	26.39	.953	24.21	.030	0.76
H	.250	6.35	1.224	31.09	1.123	28.52	.035	0.89
J	.375	9.53	1.564	39.73	1.435	36.45	.045	1.14
K	.438	11.13	1.866	47.40	1.712	43.48	.053	1.35
L	.438	11.13	2.325	59.06	2.133	54.18	.066	1.68
M	.438	11.13	2.616	66.45	2.400	60.96	.075	1.91
N	.500	12.70	2.863	72.72	2.627	66.73	.082	2.08
P	.625	15.88	3.468	88.09	3.182	80.82	.099	2.51
Q	.875	22.23	4.561	115.85	4.185	106.30	.130	3.30
R	1.000	25.40	5.406	137.31	4.960	125.98	.155	3.94
T	.750	19.05	6.883	174.83	6.315	160.40	.197	5.00
U	.750	19.05	7.409	188.19	6.798	172.67	.212	5.38
V	1.250	31.75	9.086	230.78	8.336	211.73	.260	6.60
W	1.750	44.45	11.399	289.53	10.458	265.63	.326	8.28

Table 4: Nozzle Bore Diameter

Orifice		Pre-1978				Current			
		min.		max.		min.		max.	
Std.	UM	in.	mm	in.	mm	in.	mm	in.	mm
D-1	-	.393	9.98	.398	10.11	.404	10.26	.409	10.39
E-1	-	.524	13.31	.529	13.44	.539	13.69	.544	13.82
D-2	D	.650	16.51	.655	16.64	.674	17.12	.679	17.25
E-2	E	.650	16.51	.655	16.64	.674	17.12	.679	17.25
F	F	.650	16.51	.655	16.64	.674	17.12	.679	17.25
G	G	.835	21.21	.840	21.34	.863	21.92	.868	22.05
H	H	1.045	26.54	1.050	26.67	1.078	27.38	1.083	27.51
J	J	1.335	33.91	1.340	34.04	1.380	35.05	1.385	35.18
K	K	1.595	40.51	1.600	40.64	1.650	41.91	1.655	42.04
L	L	1.985	50.42	1.990	50.55	2.055	52.20	2.060	52.32
M	M	2.234	56.74	2.239	56.87	2.309	58.65	2.314	58.78
N	N	2.445	62.10	2.450	62.23	2.535	64.39	2.540	64.52
P	P	2.965	75.31	2.970	75.44	3.073	78.05	3.078	78.18
Q	Q	3.900	99.06	3.905	99.19	4.045	102.74	4.050	102.87
R	R	4.623	117.42	4.628	117.55	4.867	123.62	4.872	123.75
T, -2T, T-3	-	6.000	152.40	6.005	152.52	6.037	153.34	6.042	153.47
T-4	T	-	-	-	-	6.202	157.53	6.208	157.68
U	U	-	-	-	-	6.685	169.80	6.691	169.95
V	V	-	-	-	-	8.000	203.20	8.005	203.33
W	W	-	-	-	-	10.029	254.74	10.034	254.86

Note: If an old style nozzle is machined to the new configuration, it should be done to a 63 micro inch finish and shall be concentric and parallel to the original centerline within .004" (0.10 mm) T.I.R.

XIV. Inspection and Part Replacement (Contd.)

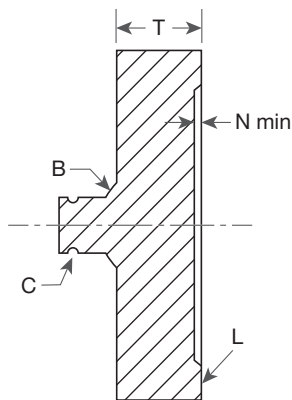

Type 1

Figure 30a: D - H Orifice Discs
D - U Orifice Discs (UM)

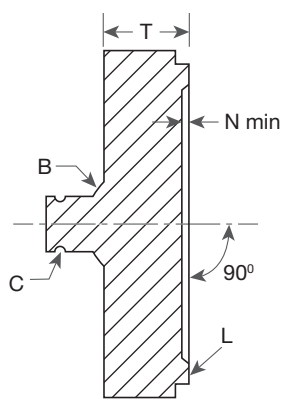

Type 2

Figure 30b:
J - U Orifice Discs

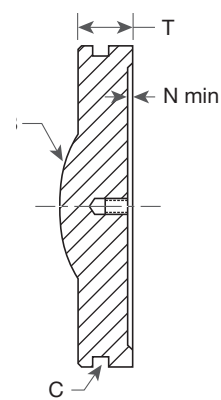

Type 3

Figure 30c: V & W Orifice Discs
(Std. & UM)

Figure 30: Disc Inspection Areas

Table 5a: Minimum Dimensions after Machining of the Disc Seat (Standard)					
Disc Type	Orifice	T min.		N min.	
		in.	mm	in.	mm
Type 1	D-1	0.155	3.94	.005	.013
	E-1	0.158	4.00	.005	.013
	D-2	0.174	4.42	.010	0.25
	E-2	0.174	4.42	.010	0.25
	F	0.174	4.42	.010	0.25
	G	0.174	4.42	.010	0.25
	H	0.335	8.51	.010	0.25
Type 2	J	0.359	9.12	.010	0.25
	K	0.422	10.72	.015	0.38
	L	0.457	11.60	.015	0.38
	M	0.457	11.60	.015	0.38
	N	0.495	12.57	.015	0.38
	P	0.610	15.49	.015	0.38
	Q	0.610	15.49	.015	0.38
	R	0.610	15.49	.015	0.38
	T-3	0.822	20.88	.015	0.38
	T-4	0.822	20.88	.015	0.38
	U	0.822	20.88	.015	0.38
Type 3	V	1.125	28.57	.015	0.38
	W	1.692	42.97	.015	0.38

Table 5b: Minimum Dimensions after Machining of the Disc Seat (Universal Media)					
Disc Type	Orifice	T min.		N min.	
		in.	mm	in.	mm
Type 1	D	.175	4.45	.010	0.25
	E	.175	4.45	.010	0.25
	F	.175	4.45	.010	0.25
	G	.169	4.29	.013	0.33
	H	.343	8.71	.018	0.46
	J	.406	10.31	.026	0.66
	K	.477	12.12	.033	0.84
	L	.530	13.46	.052	1.32
	M	.543	13.79	.059	1.50
	N	.579	14.71	.063	1.60
	P	.716	18.19	.073	1.85
	Q	.747	18.97	.099	2.51
	R	.769	19.53	.120	3.05
	T	1.013	25.73	.156	3.96
Type 3	V	1.258	31.95	.210	5.33
	W	1.888	47.96	.267	6.78

XIV. Inspection and Part Replacement (Contd.)

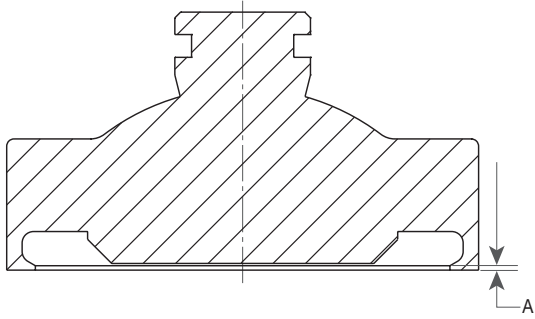

Figure 31a: D - H Orifices

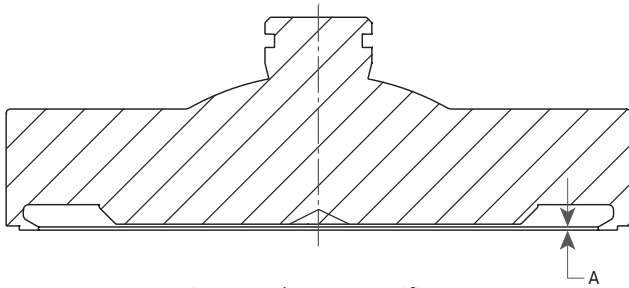

Figure 31b: J - W Orifices

Figure 31: Thermodisc Design (D - W Orifices)

Table 6: Minimum A Dimensions (Thermodisc)		
Orifice	A min.	
	in.	mm
D	.006	0.15
E	.006	0.15
F	.006	0.15
G	.006	0.15
H	.006	0.15
J	.013	0.33
K	.014	0.36
L	.014	0.36
M	.014	0.36
N	.014	0.36
P	.017	0.43
Q	.015	0.38
R	.015	0.38
T-4	.025	0.64
U	.025	0.64
V	.033	0.84
W	.033	0.84

XIV. Inspection and Part Replacement (Contd.)

F. Disc Holder Inspection Criteria

Several disc holder designs are available, depending on the service and the type of valve (see Figure 32).

For identification, the G diameter (Dia.) is provided (see Tables 7a and 7b).

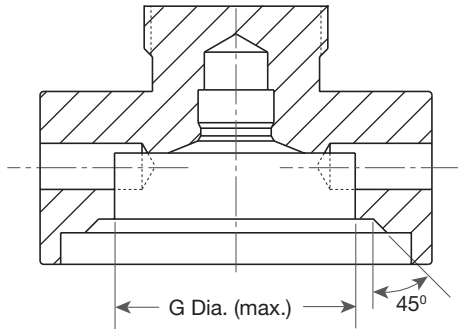

Figure 32a: Detail 1
Standard Disc Holder

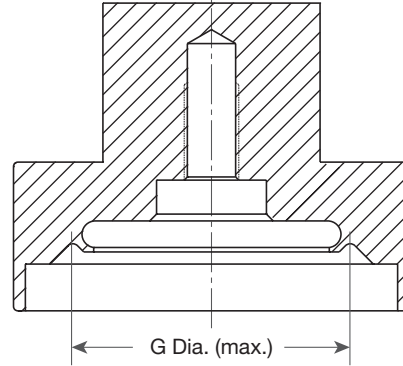

Figure 32b: Detail 2
O-Ring Disc Holder

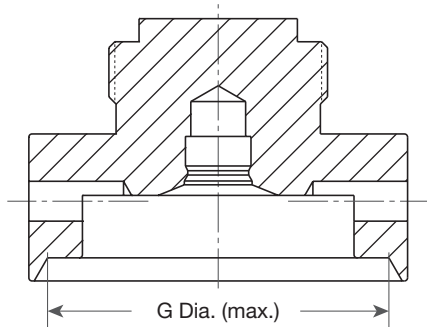

Figure 32c: Detail 3
Liquid Service Disc Holder
(LA Design)

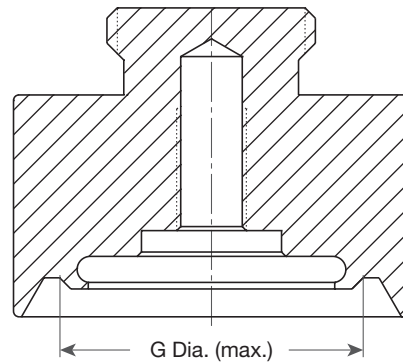

Figure 32d: Detail 4
O-Ring Liquid Service (DALA Design)
D-2, E-2, F & G Orifice

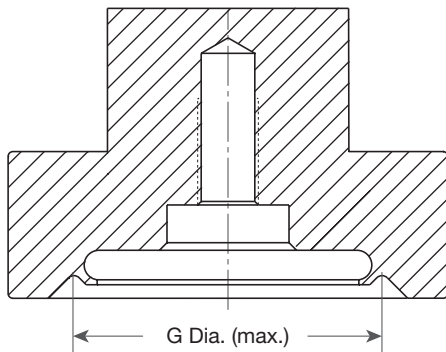

Figure 32e: Detail 5
O-Ring Liquid Service (DALA Design) - H & J Orifice

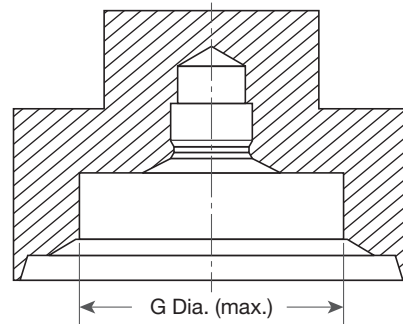

Figure 32f: Detail 6
Universal Media Service
(UM Design)

Figure 32: Disc Holder Designs

XIV. Inspection and Part Replacement (Contd.)

Table 7a: Maximum Inside Diameter (G) for Disc Holder Identification

Orifice	Standard Disc Holder						O-Ring Disc Holder					
	Air/Gas Trim				Liquid Trim		Air/Gas Trim				Liquid Trim	
	Low Pressure		High Pressure		LA Design		Low Pressure		High Pressure		DALA Design	
	in.	mm	in.	mm	in.	mm	in.	mm	in.	mm	in.	mm
D-1	.715	18.16	.715	18.16	.765	19.43	.811	20.60	.811	20.60	N/A	N/A
E-1	1.012	25.70	.922	23.41	1.061	26.95	.940	23.87	.971	24.66	N/A	N/A
D-2	1.167	29.64	1.032	26.21	1.265 ⁽³⁾	32.13 ⁽³⁾	1.105 ⁽²⁾	28.07 ⁽²⁾	1.032	26.21	1.092 ⁽⁴⁾	27.74 ⁽⁴⁾
E-2	1.167	29.64	1.032	26.21	1.265 ⁽³⁾	32.13 ⁽³⁾	1.105 ⁽²⁾	28.07 ⁽²⁾	1.032	26.21	1.092 ⁽⁴⁾	27.74 ⁽⁴⁾
F	1.167	29.64	1.032	26.21	1.265 ⁽³⁾	32.13 ⁽³⁾	1.105 ⁽²⁾	28.07 ⁽²⁾	1.032	26.21	1.092 ⁽⁴⁾	27.74 ⁽⁴⁾
G	1.272	32.31	1.183	30.05	1.375 ⁽³⁾	34.93 ⁽³⁾	1.275 ⁽²⁾	32.39 ⁽²⁾	1.183	30.05	1.265 ⁽⁴⁾	32.13 ⁽⁴⁾
H	1.491	37.87	1.394	35.41	1.656 ⁽³⁾	42.06 ⁽³⁾	1.494 ⁽²⁾	37.95 ⁽²⁾	1.394	35.41	1.494 ⁽⁵⁾	37.95 ⁽⁵⁾
J	1.929	49.00	1.780	45.21	2.156 ⁽³⁾	54.76 ⁽³⁾	1.856 ⁽²⁾	47.14 ⁽²⁾	1.780	45.21	2.155 ⁽⁴⁾	54.74 ⁽⁴⁾
K	2.126	54.00	2.126	54.00	2.469 ⁽³⁾	62.71 ⁽³⁾	2.264	57.51	2.264	57.51	2.469 ⁽³⁾	62.71 ⁽³⁾
L	2.527	64.19	2.527	64.19	3.063 ⁽³⁾	77.80 ⁽³⁾	2.527	64.19	2.527	64.19	3.063 ⁽³⁾	77.79 ⁽³⁾
M	2.980	75.69	2.980	75.69	3.359 ⁽³⁾	85.32 ⁽³⁾	2.980	75.69	2.980	75.69	3.359 ⁽³⁾	85.32 ⁽³⁾
N	3.088	78.44	3.088	78.44	3.828 ⁽³⁾	97.23 ⁽³⁾	3.088	78.44	3.088	78.44	3.828 ⁽³⁾	97.23 ⁽³⁾
P	3.950	100.33	3.950	100.33	4.813 ⁽³⁾	122.25 ⁽³⁾	3.950	100.33	3.950	100.33	4.813 ⁽³⁾	122.25 ⁽³⁾
Q	5.197	132.00	5.197	132.00	6.109 ⁽³⁾	155.17 ⁽³⁾	5.197	132.00	5.197	132.00	6.109 ⁽³⁾	155.18 ⁽³⁾
R	6.155	156.34	6.155	156.34	7.219 ⁽³⁾	183.36 ⁽³⁾	6.155	156.34	6.155	156.34	7.219 ⁽³⁾	183.36 ⁽³⁾
T, -2T, T-3	7.494	190.35	7.494	190.35	8.624 ⁽³⁾	219.05 ⁽³⁾	7.494	190.35	7.494	190.35	8.624 ⁽³⁾	219.05 ⁽³⁾
T-4	7.841	199.16	7.841	199.16	8.625 ⁽³⁾	219.08 ⁽³⁾	7.841	199.16	7.841	199.16	8.625 ⁽³⁾	219.08 ⁽³⁾
U	8.324	211.43	8.324	211.43	•	•	•	•	•	•	•	•
V	10.104	256.64	10.104	256.64	11.844 ⁽³⁾	300.84 ⁽³⁾	10.594	269.08	10.594	269.08	11.844 ⁽³⁾	300.84 ⁽³⁾
W	12.656	321.46	12.656	321.46	14.641 ⁽³⁾	371.88 ⁽³⁾	13.063	331.80	13.063	331.80	14.641 ⁽³⁾	371.88 ⁽³⁾

• Contact the factory for this information

⁽²⁾ Figure 32: Detail 2

⁽⁴⁾ Figure 32: Detail 4

⁽³⁾ Figure 32: Detail 3

⁽⁵⁾ Figure 32: Detail 5

Table 7b: Maximum Inside Diameter (G) for Disc Holder Identification - UM Disc Holder (Detail 6)

Orifice	Low Pressure		Medium Pressure		High Pressure	
	in.	mm	in.	mm	in.	mm
D	1.131	28.73	1.081	27.46	1.031	26.19
E	1.131	28.73	1.081	27.46	1.031	26.19
F	1.131	28.73	1.081	27.46	1.031	26.19
G	1.297	32.94	-	-	1.182	30.02
H	1.528	38.81	-	-	1.393	35.38
J	1.953	49.61	-	-	1.780	45.21
K	2.124	53.95	-	-	2.124	53.95
L	2.646	67.21	-	-	2.646	67.21
M	2.977	75.62	-	-	2.977	75.62
N	3.259	82.78	-	-	3.259	82.78
P	3.947	100.25	-	-	3.947	100.25
Q	5.191	131.85	-	-	5.191	131.85
R	6.153	156.29	-	-	6.153	156.29
T	7.833	198.96	-	-	7.833	198.96
U	8.432	214.17	-	-	8.432	214.17
V	10.340	262.64	-	-	10.340	262.64
W	12.972	329.49	-	-	12.972	329.49

XIV. Inspection and Part Replacement (Contd.)

Set Pressure Change: If it is necessary to change valve set pressure, it may also be necessary to change the disc holder (8). Determine if the disc holder must be changed to/from low pressure from/ to high pressure when changing the set pressure (see Tables 2).

Media Change: If the protected media is changed in form from a compressible fluid (air, gas, or steam) to a non-compressible fluid (liquid), it is necessary to change from a standard to a liquid trim disc holder for non-UM valves. No change in disc holder is required for the UM valve when the protected media changes from compressible to non-compressible, or vice-versa.

Bellows Conversion: If a conventional 1900 Series SRV has a D, E, F, G or H orifice disc holder (8), the disc holder must be replaced with a new disc holder included in the bellows conversion kit.

O-Ring Conversion: If a standard metal-seated 1900 Series SRV is to be converted to an o-ring valve, the disc holder (8) must be replaced with an o-ring disc holder which is included in the o-ring conversion kit. For K through U orifice valves, the standard disc holder may be machined to receive the larger o-ring disc.

Soft-Seat Universal Media Conversion: If a UM metal-seated 1900 Series SRV is to be converted to a soft-seat valve, the disc (2) must be replaced with a soft-seat disc (2) which is included in the soft-seat conversion kit.

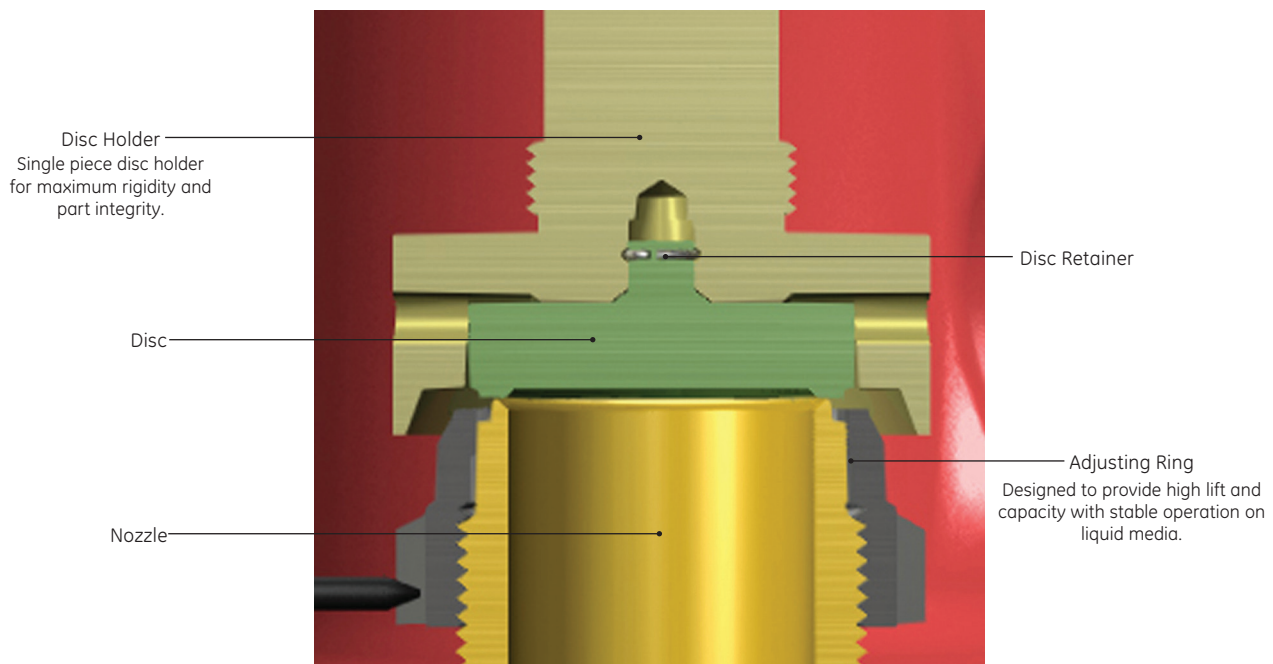

Figure 33: 1900 Series Liquid Service (LA) Internals

XIV. Inspection and Part Replacement (Contd.)

G. Guide Inspection Criteria

Replace the guide (9) if:

- Visible galling is present on the inside guiding surface.
- Gasket seating areas are pitted and cause the valve to leak between the bonnet (11) and base (1).

The guide (9) type varies depending on the valve type: O-ring valve, bellows valve, or standard valve.

Inspect the guide as follows:

- Find the correct valve orifice size and disc holder (8) measurements (see Table 8).
- Measure the barrel portion of the disc holder and compare it to the nominal measurement on Table 6 to determine the maximum allowable clearance between the disc holder and the guide.

- Replace the guide and disc holder if the clearance between the inner diameter (I.D) and the guide and/or the outer diameter (O.D) of the disc holder is not within the clearance dimensions.

H. Spindle Inspection Criteria

Replace the spindle (15) if:

- The bearing point is pitted, galled, or distorted.
- Threads are torn so that release nut and/or release locknut will not thread on or off.
- The spindle cannot be straightened less than the .007" (0.17 mm) total indicator reading (See Checking Spindle Concentricity and Figure 26).

Table 8: Allowable Clearance for Guide and Disc Holder (Std.^(1 and 2) and UM⁽²⁾)

Orifice		Bellows Type (-30)						Non-Bellows Type (-00)					
		Disc Holder Barrel O.D		Clearance				Disc Holder Barrel O.D		Clearance			
		min.		min.	max.			min.		min.	max.		
Std.	UM	in.	mm	in.	mm	in.	mm	in.	mm	in.	mm	in.	mm
D-1	D	.448	11.38	.003	0.08	.007	0.18	.993	25.22	.005	0.13	.008	0.20
E-1	E	.448	11.38	.003	0.08	.007	0.18	.993	25.22	.005	0.13	.008	0.20
D-2	D	.448	11.38	.003	0.08	.007	0.18	.993	25.22	.005	0.13	.008	0.20
E-2	E	.448	11.38	.003	0.08	.007	0.18	.993	25.22	.005	0.13	.008	0.20
F	F	.448	11.38	.003	0.08	.007	0.18	.993	25.22	.005	0.13	.008	0.20
G	G	.494	12.55	.003	0.08	.007	0.18	.993	25.22	.005	0.13	.008	0.20
H	H	.680	17.27	.004	0.10	.008	0.20	1.117	28.37	.005	0.13	.009	0.23
J	J	.992	25.20	.005	0.13	.009	0.23	0.992	25.20	.005	0.13	.009	0.23
K	K	1.240	31.50	.007	0.18	.011	0.28	1.240	31.50	.007	0.18	.011	0.28
L	L	1.365	34.67	.007	0.18	.011	0.28	1.365	34.67	.007	0.18	.011	0.28
M	M	1.742	44.25	.005	0.13	.009	0.23	1.742	44.25	.005	0.13	.009	0.23
N	N	1.868	47.45	.004	0.10	.008	0.20	1.868	47.45	.004	0.10	.008	0.20
P	P	2.302	58.47	.008	0.20	.012	0.30	2.302	58.47	.008	0.20	.012	0.30
Q	Q	2.302	58.47	.008	0.20	.012	0.30	2.302	58.47	.008	0.20	.012	0.30
R	R	2.302	58.47	.008	0.20	.012	0.30	2.302	58.47	.008	0.20	.012	0.30
T-4	T	2.302	58.47	.007	0.18	.011	0.28	2.302	58.47	.007	0.18	.011	0.28
U	U	2.302	58.47	.007	0.18	.011	0.28	2.302	58.47	.007	0.18	.011	0.28
V	V	6.424	163.17	.018	0.46	.023	0.58	6.424	163.17	.018	0.46	.023	0.58
W	W	8.424	213.97	.018	0.46	.023	0.58	8.424	213.97	.018	0.46	.023	0.58

⁽¹⁾ For valves manufactured prior to 1978, contact the factory for dimensions and clearances.

⁽²⁾ Guide and disc holder assembly: The disc holder and the guide may be retained provided their diametrical clearance falls within the limits within the table. If the fit between the assembled parts is outside the allowable clearance, replace either component or both to provide proper assembly clearance.

XIV. Inspection and Part Replacement (Contd.)

I. Spring Inspection Criteria

Replace the spring (18) if:

- Pitting and corrosion of the coils reduce coil diameter.
- Spring ends are not parallel in the free height condition.
- Obvious uneven coil spacing or spring distortion is present.
- The maximum clearance between A and A₁ and between B and B₁ (see Figure 34) is more than:

- .031" (.79 mm) for springs with an inner diameter (ID) of less than 4" (100 mm).
- .047" (1.19 mm) for springs with an ID of 4" (100 mm) or greater.

If there is constant backpressure in a conventional 1900 Series SRV (without balancing bellows), check that the cold differential set pressure of the replacement spring (18) is within the recommended range. If the relieving temperature causes the cold differential set pressure, then select a spring based on the valve's actual set pressure, not on the cold differential set pressure (See Set Pressure Compensation).

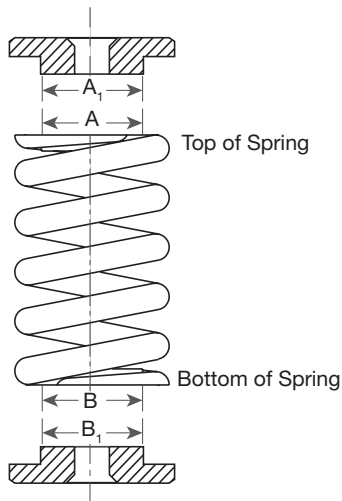

Figure 34: Spring Allowed Tolerance

ATTENTION!

If a spring must be replaced, order a spring assembly, as it includes custom fit spring washers.

XV. Reassembly of 1900 Series SRV

A. General Information

The 1900 Series SRV can be easily reassembled after the required internal parts maintenance has been performed. All parts should be clean before reassembly.

B. Preparation

Before beginning reassembly take these steps as follows:

1. Inspect guiding surfaces, bearing surfaces, flange faces, retainer recesses, and grooves for cleanliness (See Replacement Parts Planning for recommended compounds and tools).
2. Check all gaskets used during reassembly. Reuse undamaged, solid metal gaskets (not pitted or creased) and replace all soft gaskets.
3. Before installing the (flat) gaskets, apply a light uniform coating of lubricant to the surface to be sealed. Then coat the top of the gasket with lubricant.
4. If lapping of bearing points was necessary, ensure all lapping compound is removed. Then, thoroughly clean both surfaces and rinse with alcohol or another suitable cleaner.
5. Apply a light, uniform layer of lubricant to each bearing surface.
6. If the valve has an o-ring seat seal or Teflon™ seal (UM DA), the o-ring or Teflon™ should be replaced. Please refer to its tag plate (see Figure 35) to determine o-ring material and “as-built” part number.

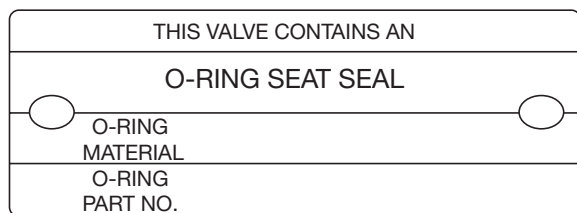

Figure 35: Valve O-Ring Tag

C. Lubrication

Use a nickel-based, anti-seize lubricant on all threads and bearing surfaces. Recommended lubricant is Jet – Lube, GE Non-metallic, product code #14613.

D. Reassembly Procedure

1. If the nozzle (2) was removed, apply thread lubricant to the nozzle threads before reinstalling it in the valve base (1).
2. Insert the nozzle (2) into the inlet flange of the base (1) and torque to the correct value (see Table 9).

Orifice		Required Torque	
Std.	UM	ft-lbs	Nm
D-1	D	95	129
E-1	E	165	224
D-2	D	95	129
E-2	E	165	224
F	F	165	224
G	G	145	197
H	H	165	224
J	J	335	454
K	K	430	583
L	L	550	746
M	M	550	746
N	N	640	868
P	P	1020	1383
Q	Q	1400	1898
R	R	1070	1451
T-4	T	1920	2603
U	U	1920	2603
V	V	1960	2657
W	W	2000	2712

3. Install the adjusting ring (3) on the nozzle (2) below the seat level so that the disc (6) will seat on the nozzle and not on the adjusting ring.
4. For restricted lift valves:
 - If the nozzle (2) did not require machining, the same limit washer (tagged during disassembly) may possibly be reused. However, lift should be checked and verified as described in Checking Lift on Lift-Restricted Valves.
 - If the nozzle was remachined, measure the required lift as described in Checking Lift on Lift-Restricted Valves and replace limit washer if necessary.
5. Assemble the disc/disc holder as follows:
 - Before assembly of the disc (6) into the disc holder (8), remove the disc retainer (7) from the back of the disc.

XV. Reassembly of 1900 Series SRV (Contd.)

- Use 1000-grit lapping compound on the bearing surface to lap the disc (6) into the disc holder (8) and to properly establish the bearing surface.
 - For D through U orifice valves with metal-to-metal discs (see Figure 1 to 6), place the disc retainer (7) into the groove in the disc (6). The retainer should “snap” into the disc holder (8) with moderate finger or hand force. Check that the disc “rocks” after set in place.
 - For V and W orifice discs (see Figure 9), place the disc into the disc holder and secure it with disc retaining bolts.
8. For D through U valves:
 - Place the guide (9) over the disc holder (8). If bellows are present, the weight of the guide will slightly compress the bellows.
 - For V and W orifice valves:
 - Install guide rings into the grooves located inside the guide ID. Make sure the space where the upper and lower guide ring ends meet is positioned 180° apart. Mark both the guide and disc holder at the point where the bottom guide ring ends meet. This mark must be faced 180° away from the outlet when the assembly is place into the valve. Gently lower the guide down onto the disc holder ensuring that guide rings remain in their respective groove.

ATTENTION!

Do not use excessive force to insert the disc (6) into the disc holder (8).

- For O-ring disc sizes D through J (see Figure 10a), reassemble the disc holder using a new O-ring Seat Seal, O-ring retainer, and retainer lock screw(s).
 - For O-ring disc sizes K through U (see Figure 10b), reassemble the disc using a new O-ring Seat Seal, O-ring retainer, and retainer lock screws. Assemble the disc into the disc holder.
 - For soft-seat (UM DA) discs (see Figure 10c), reassemble the disc using a new Teflon™ seal, soft-seat retainer, and retainer lock screw(s).
6. Install the bellows gasket and bellows ring as follows:
 - For bellows valves D through U (see Figure 7):
 - Clamp the stem portion of the disc holder (8), barrel-end up, firmly between two wooden V-blocks in a vise.
 - Place a new bellows gasket on the disc holder.
 - Thread the bellows ring, hand-tight, down to the gasket on the disc holder.
 - Use a pin spanner wrench or special cable-type wrench to tighten the bellows ring until a pressure-tight joint is formed.
 - For bellows valves V and W:
 - Place a new bellows gasket on the disc holder.
 - Bolt the assembly in place and tighten bolts to 7-9 ft-lbs (9.5-12.2 Nm).
 7. On restricted lift valves, install the limit washer with the chamfered side down.
 9. Set the disc holder (8), disc side down, on the work surface. Place a small amount of 1000- grit lapping compound onto the ball end of the spindle (15) and place it in the spindle socket of the disc holder. Turn the spindle clockwise and then counterclockwise to seat the spindle/disc holder bearing point. When finished, clean lapping compound from all parts.
 10. Spread a small amount of 320-grit lapping compound on the spring washer bearing surface.
 11. Place the spring washer (17) over the spindle/spring washer bearing surface and turn it clockwise and then counterclockwise to seat it on the bearing surface. In the same manner, lap the adjusting screw (19) into the bearing surface of the upper spring washer to establish a smooth bearing surface. When finished, clean lapping compound from all parts.
 12. Place the spindle retainer (16) over the end of the spindle head or disc holder (8), as applicable.
 13. Apply lubricant sparingly to the ball tip of the spindle (15).
 14. Place a new guide gasket (10) in the base (1).
 15. Install the spindle/disc guide assembly as follows:
 - For D through L size valves:
 - Place the spindle (15) in the disc holder (8) and align the spindle retainer (16) so that the gap is midway between the two slots.
 - Use a screwdriver to compress the spindle retainer and guide it into the retaining groove. Ensure the spindle turns freely.
 - Lift complete assembly and carefully lower it into the valve base (1).

XV. Reassembly of 1900 Series SRV (Contd.)

- Ensure proper fit for a conventional valve by aligning the hole in the guide (9) over the extended end of the eductor tube (40).
 - For M through U size valves:
 - Install lifting tool (see Figure 14) onto disc holder and carefully lower the disc holder assembly into the valve base.
 - Ensure proper fit for a conventional valve by aligning the hole(s) in the guide over the extended end of the eductor tube(s).
 - Then, install the spindle in the disc holder and align the spindle retainer so that the gap is midway between the two slots.
 - Use a screwdriver to compress the spindle retainer and guide it into the retaining groove. Ensure the spindle turns freely.
 - For V and W size valves:
 - Using the same lifting lugs used during disassembly (see Figure 14), carefully lower the disc holder assembly into the valve base.
 - Install the spindle in the disc holder and align the spindle retainer so that the gap is midway between the two slots.
 - Use a screwdriver to compress the spindle retainer and guide it into the retaining groove. Ensure the spindle turns freely.
16. Apply a small quantity of lubricant to the spring washer bearing surface of the spindle (15).
 17. Place the spring assembly on the spindle (15).
 18. Place a new bonnet gasket (12) in the base (1) before installing the bonnet (11). Uniformly tighten the stud nuts (14) using the appropriate bolt tightening pattern (see Figure 36). Determine the required torque for the subject valve (see Table 10). Determine the torque values for each round of the pattern (see Table 11). The last round ensures that all stud nuts are at the required torque.
 19. With the adjusting screw locknut (20) assembled near the top of the adjusting screw (19), apply a small quantity of lubricant to the spherical end and threads of the adjusting screw.
 - For V and W orifices, use the setting device to assemble the spring plunger and adjusting screw. Contact the factory for procedure on how to use the setting device.
 20. Thread the adjusting screw (19) into the bonnet (11) until it contacts the spring washer (17).

Table 10: Bonnet Nut Torque

Orifice		1905		1906		1910		1912		1914		1916		1918	
Std.	UM	ft lb	Nm	ft lb	Nm	ft lb	Nm	ft lb	Nm	ft lb	Nm	ft lb	Nm	ft lb	Nm
D-1	-	55	75	55	75	55	75	60	81	60	81	60	81	120	163
E-1	-	55	75	55	75	55	75	60	81	60	81	60	81	120	163
D-2	-	55	75	55	75	55	75	60	81	60	81	60	81	120	163
E-2	-	55	75	55	75	55	75	60	81	60	81	60	81	120	163
F	F	55	75	55	75	55	75	60	81	70	95	70	95	115	156
G	G	55	75	55	75	55	75	60	81	70	95	70	95	75	102
H	H	90	122	90	122	60	81	75	102	65	88	65	88	----	----
J	J	60	81	60	81	75	102	100	136	100	136	100	136	----	----
K	K	65	88	65	88	60	81	60	81	135	183	145	197	----	----
L	L	75	102	75	102	90	122	90	122	140	190	140	190	----	----
M	M	95	129	95	129	110	149	95	129	95	129	----	----	----	----
N	N	105	142	105	142	130	176	85	115	85	115	----	----	----	----
P	P	120	163	120	163	145	197	125	169	125	169	----	----	----	----
Q	Q	105	142	105	142	125	169	150	203	----	----	----	----	----	----
R	R	115	156	115	156	115	156	135	183	----	----	----	----	----	----
T-4	T	95	129	95	129	95	129	----	----	----	----	----	----	----	----
U	U	95	129	95	129	95	129	----	----	----	----	----	----	----	----
V	V	130	176	130	176	130	176	----	----	----	----	----	----	----	----
W	W	130	176	130	176	130	176	----	----	----	----	----	----	----	----

XV. Reassembly of 1900 Series SRV (Contd.)

Table 10: Bonnet Nut Torque (Contd.)

Orifice		1920		1921		1922		1923		1924		1926		1928	
Std.	UM	ft lb	Nm	ft lb	Nm	ft lb	Nm	ft lb	Nm	ft lb	Nm	ft lb	Nm	ft lb	Nm
D-1	-	55	75	----	----	55	75	----	----	60	81	60	81	115	156
E-1	-	55	75	----	----	55	75	----	----	60	81	60	81	115	156
D-2	-	55	75	----	----	55	75	----	----	60	81	60	81	115	156
E-2	-	55	75	----	----	55	75	----	----	60	81	60	81	115	156
F	F	55	75	----	----	55	75	----	----	70	95	70	95	115	156
G	G	55	75	----	----	60	81	----	----	70	95	70	95	75	102
H	H	60	81	----	----	60	81	----	----	75	102	85	115	----	----
J	J	75	102	----	----	75	102	----	----	100	136	100	136	----	----
K	K	60	81	----	----	60	81	----	----	60	81	140	190	----	----
L	L	90	122	----	----	90	122	----	----	140	190	140	190	----	----
M	M	90	122	----	----	95	129	----	----	95	129	----	----	----	----
N	N	130	176	----	----	85	115	----	----	85	115	----	----	----	----
P	P	145	197	----	----	----	----	125	169	125	169	----	----	----	----
Q	Q	105	142	----	----	150	203	----	----	----	----	----	----	----	----
R	R	115	156	----	----	135	183	----	----	----	----	----	----	----	----
T-4	T	125	169	----	----	----	----	----	----	----	----	----	----	----	----
U	U	125	169	----	----	----	----	----	----	----	----	----	----	----	----
V	V	130	176	----	----	----	----	----	----	----	----	----	----	----	----
W	W	130	176	----	----	----	----	----	----	----	----	----	----	----	----

- Use pliers to hold the spindle (15) and prevent it from turning in the disc holder (8). Turn the adjusting screw (19) clockwise until the original distance between the end of the spindle and the top of the adjusting screw is obtained. This method of compressing the spring (18) will approximately reestablish the original set pressure. The valve must still be reset for the required pressure.
- Restore the adjusting ring (3) to its original position, with reference to the disc holder (8), as recorded.
- Fit the adjusting ring pin (4) with a new adjusting ring pin gasket (5).
- Install the adjusting ring pin (4) in the valve assembly in the original position. If the original position is not known, verify the number of notches

on the adjusting ring (3) and refer to Tables 12, 13, 14 or 15 depending on the valve serial number or trim. Set the ring position according to the applicable set pressure and orifice size.

The valve is now ready for setting and testing.

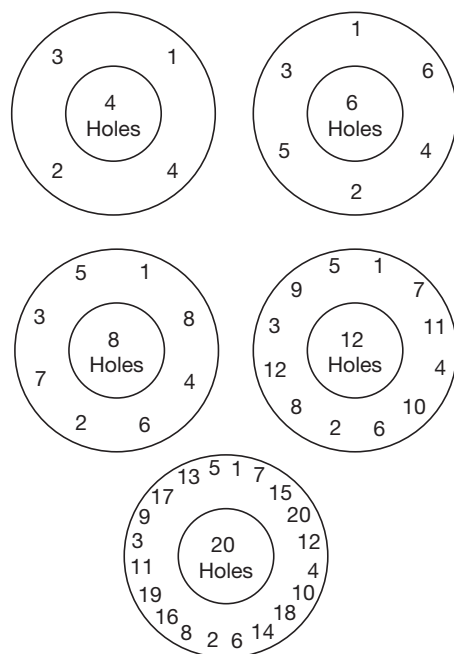

Figure 36: Bolt Tightening Patterns

Table 11: Torque Required for Each Round of Pattern

Round	Percentage of Required Torque
1	Wrench Tight
2	25
3	60
4	100
5	100

XV. Reassembly of 1900 Series SRV (Contd.)

Table 12a: Adjusting Ring Setting (Standard Trim) for Valves with Serial Numbers BEFORE TK-68738⁽²⁾

Orifice	No. of Notches on Adj. Ring	Set Pressure 100 psig (6.90 bar) and Below	Set Pressure Above 100 psig (6.90 bar)
D-1	16	1 Notch	4 Notches
D-2	16 24	1 Notch 2 Notches	4 Notches 6 Notches
E-1	16	1 Notch	4 Notches
E-2	16 24	1 Notch 2 Notches	4 Notches 6 Notches
F	16 24	1 Notch 2 Notches	4 Notches 6 Notches
G	18 30	1 Notch 2 Notches	4 Notches 6 Notches
H	24 30	1 Notch 2 Notches	5 Notches 6 Notches
J	24 30	1 Notch 2 Notches	5 Notches 8 Notches
K	24 32	6 Notches 8 Notches	14 Notches 19 Notches
L	24 40	6 Notches 10 Notches	18 Notches 31 Notches
M	24 40	7 Notches 10 Notches	20 Notches 30 Notches
N	24 40	7 Notches 10 Notches	20 Notches 30 Notches
P	24 40	8 Notches 14 Notches	24 Notches 42 Notches
Q	28 48	10 Notches 17 Notches	28 Notches 47 Notches
R	32 48	28 Notches 42 Notches	36 Notches 64 Notches
T	24	30 Notches	38 Notches
W	-	-	-

⁽²⁾ Valve Serial Numbers are alphabetically and numerically chronological.

Table 12b: Adjusting Ring Setting (Standard Trim) for Valves with Serial Numbers AFTER TK-68738⁽²⁾

Orifice	No. of Notches on Adj. Ring	Set Pressure 100 psig (6.90 bar) and Below	Set Pressure Above 100 psig (6.90 bar)
D-1	16	1 Notch	4 Notches
D-2	16 24	1 Notch 2 Notches	4 Notches 6 Notches
E-1	16	1 Notch	4 Notches
E-2	16 24	1 Notch 2 Notches	4 Notches 6 Notches
F	16 24	1 Notch 2 Notches	4 Notches 6 Notches
G	18 30	1 Notch 2 Notches	4 Notches 6 Notches
H	24 30	1 Notch 2 Notches	5 Notches 6 Notches
J	24 30	1 Notch 2 Notches	5 Notches 8 Notches
K	24 32	2 Notches 2 Notches	5 Notches 7 Notches
L	24 40	2 Notches 4 Notches	6 Notches 11 Notches
M	24 40	2 Notches 4 Notches	7 Notches 12 Notches
N	24 40	3 Notches 4 Notches	8 Notches 13 Notches
P	24 40	3 Notches 5 Notches	9 Notches 16 Notches
Q	28 48	5 Notches 8 Notches	15 Notches 25 Notches
R	32 48	7 Notches 10 Notches	20 Notches 30 Notches
T	24	6 Notches	19 Notches
W	24	10 Notches	30 Notches

⁽²⁾ Valve Serial Numbers are alphabetically and numerically chronological.

XV. Reassembly of 1900 Series SRV (Contd.)

Orifice	No. of Notches	Metal Seat Liquid Trim (MS - LA) ⁽¹⁾	Soft Seat Liquid Trim (DA - LA)	
		Position ⁽²⁾	Pressure Range	Position ⁽²⁾
D-2	24	5 Notches	Set < 100 psig (6.89 barg) Set > 100 psig (6.89 barg)	1 Notch ⁽³⁾ 3 Notches ⁽³⁾
E-2	24	5 Notches	Set < 100 psig (6.89 barg) Set > 100 psig (6.89 barg)	1 Notch ⁽³⁾ 3 Notches ⁽³⁾
F	24	5 Notches	Set < 100 psig (6.89 barg) Set > 100 psig (6.89 barg)	1 Notch ⁽³⁾ 3 Notches ⁽³⁾
G	30	5 Notches	Set < 100 psig (6.89 barg) Set > 100 psig (6.89 barg)	1 Notch 5 Notches
H	30	5 Notches	All Pressures	7 Notches ⁽³⁾
J	30	5 Notches	Set < 80 psig (5.52 barg) Set > 80 psig (5.52 barg)	1 Notch ⁽³⁾ 5 Notches ⁽³⁾
K	32	5 Notches	All Pressures	5 Notches
L	40	5 Notches	All Pressures	5 Notches
M	40	5 Notches	All Pressures	5 Notches
N	40	5 Notches	All Pressures	5 Notches
P	40	5 Notches	All Pressures	5 Notches
Q	48	5 Notches	All Pressures	5 Notches
R	48	5 Notches	All Pressures	5 Notches
T-4	24	5 Notches	All Pressures	5 Notches
U	24	5 Notches	All Pressures	5 Notches

⁽¹⁾ MS-LA uses standard trim adjusting ring

⁽²⁾ Position Below Disc Holder

⁽³⁾ Ring setting to be made with no pressure acting on the valve and no compression on the spring

Orifice	No. of Notches	Affected Set Pressure Range & Adjusting Ring Position ⁽¹⁾																			
		3 Notches		5 Notches		10 Notches		15 Notches		20 Notches											
		psig	barg	psig	barg	psig	barg	psig	barg	psig	barg										
D	24	0	100	0	6.89	101	200	6.96	13.79	201	400	13.86	27.58	401	800	27.65	55.16	801	1600	55.23	110.32
E	24	0	100	0	6.89	101	200	6.96	13.79	201	400	13.86	27.58	401	800	27.65	55.16	801	1600	55.23	110.32
F	24	0	300	0	20.68	301	600	20.75	41.37	601	1200	41.44	82.74	1201	2400	82.81	165.47	2401	4800	165.54	330.95
G	30	0	200	0	13.79	201	400	13.86	27.58	401	800	27.65	55.16	801	1600	55.23	110.32	1601	3200	110.39	220.63
H	30	0	100	0	6.89	101	200	6.96	13.79	201	400	13.86	27.58	401	800	27.65	55.16	801	1600	55.23	110.32
J	30	-	-	-	-	0	50	0.00	3.45	51	125	3.52	8.62	126	250	8.69	17.24	251	500	17.31	34.47
K	32	-	-	-	-	0	50	0.00	3.45	51	125	3.52	8.62	126	250	8.69	17.24	251	500	17.31	34.47
L	40	-	-	-	-	0	50	0.00	3.45	51	125	3.52	8.62	126	250	8.69	17.24	251	500	17.31	34.47
M	40	-	-	-	-	0	25	0.00	1.72	26	50	1.79	3.45	51	125	3.52	8.62	126	250	8.69	17.24
N	40	-	-	-	-	0	25	0.00	1.72	26	50	1.79	3.45	51	125	3.52	8.62	126	250	8.69	17.24
P	40	-	-	-	-	0	25	0.00	1.72	26	50	1.79	3.45	51	125	3.52	8.62	126	250	8.69	17.24
Q	48	-	-	-	-	-	-	-	-	0	25	0.00	1.72	26	50	1.79	3.45	51	100	3.52	6.89
R	48	-	-	-	-	-	-	-	-	-	-	-	-	0	25	0.00	1.72	26	50	1.79	3.45
T	24	-	-	-	-	0	25	0.00	1.72	26	50	1.79	3.45	51	100	3.52	6.89	101	200	6.96	13.79
U	24	-	-	-	-	-	-	-	-	-	-	-	-	0	25	0.00	1.72	26	50	1.79	3.45
V	24	-	-	-	-	-	-	-	-	-	-	-	-	0	25	0.00	1.72	26	50	1.79	3.45
W	24	-	-	-	-	-	-	-	-	-	-	-	-	0	25	0.00	1.72	26	50	1.79	3.45

⁽¹⁾ Position Relative to Disc Holder

XV. Reassembly of 1900 Series SRV (Contd.)

Table 14: Ring Settings for Universal Media Valves (Contd.)

Orifice	No. of Notches	Affected Set Pressure Range & Adjusting Ring Position ⁽¹⁾															
		25 Notches				30 Notches				35 Notches				40 Notches			
		psig		barg		psig		barg		psig		barg		psig		barg	
D	24	1601	3200	110.39	220.63	3201	6250	220.70	430.92	-	-	-	-	-	-	-	-
E	24	1601	3200	110.39	220.63	3201	6250	220.70	430.92	-	-	-	-	-	-	-	-
F	24	4801	6250	331.02	430.92	-	-	-	-	-	-	-	-	-	-	-	-
G	30	3201	5000	220.70	344.74	-	-	-	-	-	-	-	-	-	-	-	-
H	30	1601	3200	110.39	220.63	3201	3300	220.70	227.53	-	-	-	-	-	-	-	-
J	30	501	2000	69.02	137.90	2001	3100	137.96	213.74	-	-	-	-	-	-	-	-
K	32	501	2000	69.02	137.90	2001	3000	137.96	206.84	-	-	-	-	-	-	-	-
L	40	501	2000	69.02	137.90	2001	2900	137.96	199.95	-	-	-	-	-	-	-	-
M	40	251	500	17.31	34.47	501	1000	34.54	68.95	1001	1600	69.02	110.32	-	-	-	-
N	40	251	500	17.31	34.47	501	1000	34.54	68.95	1001	1600	69.02	110.32	-	-	-	-
P	40	251	500	17.31	34.47	501	1000	34.54	68.95	1001	1700	69.02	117.21	-	-	-	-
Q	48	101	200	6.96	13.79	201	400	13.86	27.58	401	900	27.65	62.05	-	-	-	-
R	48	51	100	3.52	6.89	101	200	6.96	13.79	201	400	13.86	27.58	401	650	27.65	44.82
T	24	201	360	13.86	24.82	-	-	-	-	-	-	-	-	-	-	-	-
U	24	51	100	3.52	6.89	101	200	6.96	13.79	201	360	13.86	24.82	-	-	-	-
V	24	51	100	3.52	6.89	101	200	6.96	13.79	201	300	13.86	20.68	-	-	-	-
W	24	51	100	3.52	6.89	101	200	6.96	13.79	201	300	13.86	20.68	-	-	-	-

⁽¹⁾ Position Relative to Disc Holder

ATTENTION!

If the valve has an o-ring seat seal, tighten and lock the adjusting screw (19) before final setting of the adjusting ring (3).

ATTENTION!

Ensure the adjusting ring pin (4) enters the notch in the adjusting ring (3) but does not bind the adjusting ring. If binding occurs, cut the adjusting ring pin until adjusting ring moves freely from side-to-side within the notch.

XVI. Setting and Testing

A. General Information

Before putting the reconditioned valve in service, it must be set to open at the required set pressure as shown on the nameplate. Although the valve can be set on the service installation, it is more convenient to set the valve and check seat tightness on a test stand. Any spring replacement shall be in accordance with current GE guidelines.

B. Test Equipment

The test stand used for testing SRVs normally consists of a pressure source supply line with a throttle valve and receiver that have the following features:

- Outlet for attaching the valve to be tested
- Pressure gauge with a shut-off valve
- Drain line with a shut-off valve
- Adequate receiver volume for the valve to be tested and to achieve proper operation

C. Test Media

For best results, valves shall be tested by type as follows:

- Steam valves are tested on saturated steam.
- Air or gas valves are tested on air or gas at ambient temperature.
- Liquid valves are tested on water at ambient temperature.

D. Setting the Valve

Set the valve to open at the set pressure as shown on the nameplate. If a cold differential set pressure is indicated on the nameplate, set the valve to open at that pressure. (The cold differential set pressure is the set pressure corrected to compensate for backpressure and/or operating temperature.) A new cold differential set pressure may need to be determined if changes are to be made to the set pressure or backpressure or if the service temperature changes.

E. Set Pressure Compensation

Cold Differential Set Pressure for Temperature Compensation

During production testing, the SRV is often tested at temperatures that are different from the temperatures the SRV will be exposed to in service. Increasing the temperature from ambient temperature causes the set pressure to decrease. The decrease in set pressure is due to thermal expansion of the seating area and spring relaxation. Therefore, it is important to compensate for the difference between production test temperature and service temperature. The service temperature is the normal operating temperature of the SRV. If the operating temperature is unavailable, do not correct the SRV set pressure.

Table 15 lists the set pressure multipliers to be used when computing the cold differential set (CDS) pressure for valves being set on an air or water test stand at ambient temperatures

Valves to be used in saturated steam service are tested on saturated steam. Therefore, no CDS is required. However, valves in superheated steam service are tested on saturated steam and require a CDS.



XVI. Setting and Testing (Contd.)

Table 15: Set Pressure Multipliers for Cold Differential Set Pressure at Ambient Temperature

Operating Temp.		Multiplier	Operating Temp.		Multiplier
°F	°C		°F	°C	
250	120	1.003	900	498	1.044
300	149	1.006	950	510	1.047
350	177	1.009	1000	538	1.050
400	204	1.013	1050	565	1.053
450	248	1.016	1100	593	1.056
500	260	1.019	1150	621	1.059
550	288	1.022	1200	649	1.063
600	316	1.025	1250	676	1.066
650	343	1.028	1300	704	1.069
700	371	1.031	1350	732	1.072
750	415	1.034	1400	760	1.075
800	427	1.038	1450	788	1.078
850	454	1.041	1500	815	1.081

Table 16 lists the multiplier to be used based on temperature above the saturated temperature (degrees of superheat).

Table 16: Set Pressure Multipliers for Cold Differential Set Pressure

Superheat Temperature		
Degrees of Superheat, Temp. above Sat.		Multiplier
°F	°C	
100	55.6	1.006
200	111.1	1.013
300	166.7	1.019
400	222.2	1.025
500	277.8	1.031
600	333.3	1.038
700	388.9	1.044
800	444.4	1.050

Cold Differential Set Pressure for Back Pressure Compensation

ATTENTION!

Install a bellows to allow the set pressure to remain constant for valves with variable superimposed backpressure.

When a conventional 1900 Series SRV operates with a constant backpressure, the cold differential set (CDS) pressure is the set pressure minus the constant backpressure.

When Consolidated Type 1900-30 D-2, 1900-30 E-2, and 1900-30 F through W balanced bellows valves are used with constant or variable backpressure, no compensation to the valve's set pressure is required due to backpressure.

Sample Calculations for 1900 Series Consolidated Safety Relief Valve

Set pressure 2500 psig (172.37 barg), temperature 500°F (260°C), backpressure atmospheric.

Set Pressure 2500 psig (172.37 barg)
 Multiplier (see Table 16) X1.019

Cold Differential Set Pressure 2548 psig (175.68)

Set pressure 2500 psig (172.37 barg), temperature 500°F (260°C), constant backpressure 150 psig (10.34 barg)

Set Pressure 2500 psig (172.37 barg)
 Minus Constant Back Pressure ... -150 psig (-10.34 barg)

Differential Pressure 2350 psig (162.03 barg)

Multiplier (see Table 16) X1.019

Cold Differential Set Pressure 2395 psi

Set pressure 2500 psig (172.37 barg), temperature 100° F (260°C), constant backpressure 150 psig (10.34 barg)

Set Pressure 2500 psig (172.37 barg)
 Minus Constant Back Pressure ... -150 psig (-10.34 barg)

Cold Differential Set Pressure ... 2350 psig (162.03 barg)

Set pressure 400 psig (27.58 barg) on superheated steam, temperature 650° F (343.3 °C), backpressure atmospheric Operating Temperature 650° F (343.3 °C)

Minus Temperature of Saturated Steam at 400 psig (27.58 barg) -448° F (-266.7°C)

Degrees of Superheat 202° F (94.4°C)

Set Pressure 400 psig (27.58 barg)

Multiplier (see Table 16) X1.013

Cold Differential Set Pressure 405 psig (27.92 barg).

XVI. Setting and Testing (Contd.)

ATTENTION!

- Ensure valves for steam service are set using saturated steam.
- Ensure valves for gaseous service are set using air or nitrogen.
- Ensure valves for liquid service are set using water.

ATTENTION!

The ASME Boiler and Pressure Vessel Code Section VIII set pressure tolerance is 2 psi (.14 bar) \leq 70 psi (4.8 bar) and 3% \leq 70 psi (4.8 bar).

F. Setting the Pressure

1. Before mounting the valve on the test stand, remove all dirt, sediment, or scale from the test tank nozzle and the inlet port of the valve. Ensure the test gauge has recently been calibrated on a deadweight gauge tester.
2. Mount the valve on the test stand.
3. If the adjusting screw (19) of the reconditioned valve has been turned down to its original position, slowly bring the pressure up in the test tank to the CDS pressure. If the valve opens before the desired pressure is reached, additional compression is required on the spring (18), as follows:
 - Hold the spindle (15) to prevent rotation and turn the adjusting screw clockwise.
 - If the valve does not open at the desired pressure, maintain the required pressure in the test tank and slowly release the compression on the spring by turning the adjusting screw counterclockwise until the valve opens.
 - Continue adjustment until the valve opens at the desired pressure.
4. After the required set pressure is obtained, tighten the adjusting screw locknut (20) and repeat the test. Obtain at least two repeat openings at the same pressure to ensure the valve is set accurately.

ATTENTION!

On compressible fluids, set pressure is defined as the pressure where the valve pops open, NOT as the pressure when it begins to simmer.

ATTENTION!

On liquid valves, set pressure is indicated by the first continuous flow of water from the valve outlet.

G. Seat Tightness Testing

General Information: Set up a typical test arrangement for determining seat tightness for SRVs on air or gas service (in accordance with ANSI B147.1/API RP 527) (see Figure 37).

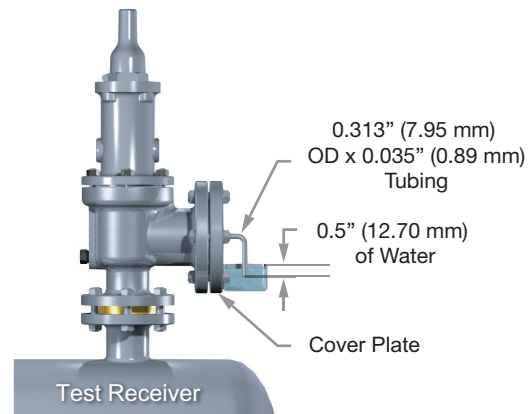

Figure 37: Typical Test Arrangement

ATTENTION!

Leakage may be detected by application of a soap solution, or equivalent, at points of possible leakage.

1. Cut the end of a piece of .313" (7.93 mm) OD tubing with .035" (0.89 mm) wall so that it is square and smooth.
2. Insert the tubing so that it is perpendicular to and .5" (12.7 mm) below the surface of the water.
3. Use the tubing to take a leakage measurement.

G.1 Metal-to-Metal Seats

1. With the valve mounted vertically (see Figure 37), determine the leakage rate, in bubbles per minute, with pressure at the SRV inlet held at 90% of the set pressure immediately after popping. For valves set at 50 psig (3.45 barg) or below, hold pressure at 5 psig (0.34 barg) below set point. The test pressure shall be applied for a minimum of 1 minute for valves on inlet sizes through 2" (50.8 mm); 2 minutes for sizes 2.5" (63.5 mm), 3" (76.2 mm) and 4" (101.6 mm), and 5 minutes for the 6" (152.4 mm),

XVI. Setting and Testing (Contd.)

8" (203.2 mm), 10" (254 mm) and 12" (304.8 mm) sizes. For metal-to-metal valves designated for gaseous service, the leakage rate shall not exceed maximum bubbles per minute (see Table 17). When using saturated steam as the test medium, the test pressure shall be held for at least 3 minutes.

- Check that there is no visible leakage for valves designated for steam service (and tested on steam) or for liquid service (and tested on water).

G.2 O-Ring Seat Seal Valve

The tightness standard for O-ring seat seal valves shall be no leakage at or below the test pressures listed (see Table 18).

Table 17: Valve Leakage Rate (Metal Seat)

Set Pressure (60°F or 15.6°C)		Valve Orifice D & E			Valve Orifice F and Larger		
		Approximate Leakage per 24 hrs			Approximate Leakage per 24 hrs		
Pressure		Leakage Rate (Bubbles per Minute)	ft ³	m ³	Leakage Rate (Bubbles per Minute)	ft ³	m ³
(psig)	(barg)						
15-1000	1.03-68.95	40	0.6	0.02	20	0.3	0.01
1500	103.42	60	0.9	0.03	30	0.45	0.01
2000	137.90	80	1.2	0.03	40	0.6	0.02
2500	172.37	100	1.5	0.04	50	0.75	0.02
3000	206.84	100	1.5	0.04	60	0.9	0.03
4000	275.79	100	1.5	0.04	80	1.2	0.03
5000	344.74	100	1.5	0.04	100	1.5	0.04
6000	413.69	100	1.5	0.04	100	1.5	0.04

Table 18: Leakage Rate (Soft Seat)

Set Pressure		Test Pressure ⁽¹⁾	
(psig)	(barg)	(psig)	(barg)
3	2.07	1.5	1.03
4	2.76	2	1.38
5	3.45	2.5	1.72
6	4.14	3	2.07
7.0 – 14.0	4.83 – 9.65	3.0 below Set	2.07 below set
15.0 – 30.0	10.34 – 20.68	90% of Set	90% of Set
31.0 – 50.0	22.06 – 34.47	92% of Set	92% of Set
51.0 – 100.0	35.16 – 68.95	94% of Set	94% of Set
Set > 100.0	Set > 68.95	95% of Set	95% of Set

⁽¹⁾ Set pressures below 15 psig are outside the scope of API 527.

XVI. Setting and Testing (Contd.)

H. Recommended Backpressure Testing for Joint Leakage

If the valve is to be used in a closed discharge system, backpressure-test the valve after it has been set for the correct opening pressure. Conduct testing by installing the screwed cap (21) with a cap gasket (27) and applying air or nitrogen to the base drain connection or to the valve outlet. Seal all other openings.

Test pressure should be the greater of 30 psig (2 barg) or the actual valve backpressure. Hold air or nitrogen pressure for 3 minutes before applying leak detector solution to all connections (joints).

On bellows valves, hand-tighten a clean pipe plug in the bonnet vent connection in order to obtain the smallest possible leak path. Remove this plug after the test.

Apply liquid leak detector to the following SRV components and examine for leakage during backpressure testing:

- Nozzle/base joint.
- Adjusting ring pin seal.
- Base/bonnet joint.
- Bonnet/cap joint.
- “Tight” bonnet vent plug, if conventional valve.
- “Loose” bonnet vent plug, if bellows valve.

If a leak is discovered, attempt repair of the leaking joint(s) by tightening it while the SRV is still on the stand. If the leak continues, tear down the leaking joint(s) and inspect both the metal surface(s) and gasket(s). If the valve internals have been disturbed, it is necessary to retest in accordance with the instructions within this manual. Otherwise, repeat the backpressure tests outlined above.



I. Blowdown Adjustment

Blowdown adjustments are made by means of the adjusting ring (3) on 1900 Series SRVs.

If longer or shorter blowdown is required, it can be obtained as follows:

ATTENTION!

Unless the test stand capacity is equal to or greater than that of the valve, return the adjusting ring (3) to the recommended position and do not attempt to set blowdown (see Tables 12 through 15).

To increase the blowdown (lower reseating pressure), raise the adjusting ring (3) by moving the notches from left to right past the ring pin hole.

ATTENTION!

The valve will not achieve rated relieving capacity if the adjusting ring (3) is positioned too low.

To decrease the blowdown (raise reseating pressure), lower the adjusting ring by moving the notches from right to left past the adjusting ring pin hole.

XVI. Setting and Testing (Contd.)

J. Hydrostatic Testing and Gaging

When hydrostatic tests are required after installation of an SRV, remove the SRV and replace it with a blind flange. If the hydrostatic test pressure will not be greater than the operating pressure of the equipment, a test gag may be used. Very little force, i.e., hand-tight pressure, on the test gag is sufficient to hold hydrostatic pressures. Too much force applied to the gag may bend the spindle (15) and damage the seat. After a hydrostatic test, the gag must be removed and replaced by the sealing plug furnished for this purpose (see Figure 38). (Test gags for Consolidated SRVs can be furnished for all types of caps and lifting gears.)

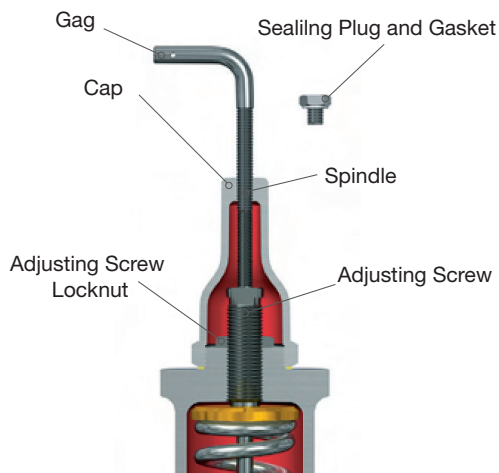

Figure 38: Hydrostatic Testing

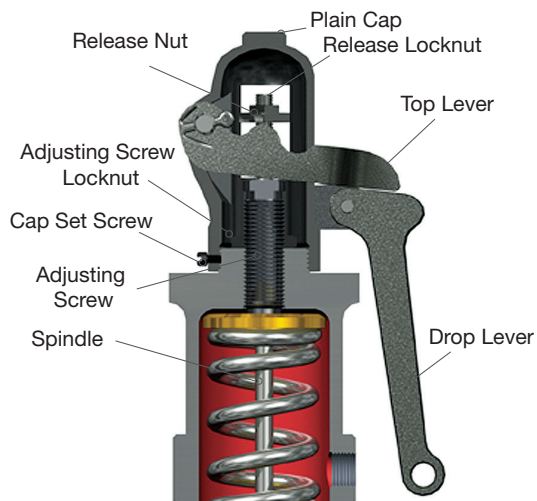

Figure 39: Plain Lever

K. Manual Popping of the Valve

Consolidated SRVs are furnished, when so ordered, with packed or plain lifting levers for hand-popping or with an air-operated lifting device for remote control (see Figures 40 through 42).

When the valve is to be opened by hand, ensure the pressure at the valve inlet is at least 75% of the valve's set pressure. Under flowing conditions, the valve must be fully lifted from its seat so that dirt, sediment, and scale do not become trapped on the seating surfaces. When allowing the valve to close under flowing conditions, completely release the lever from maximum lift to snap the valve back on its seat.

Since the deadweight of a Packed Lever, and Air-Operated Packed Lever has a tendency to lift the valve, the lever should be supported or counterweighted so that the lifting fork does not contact the release nut (see Figures 41 and 42)

The air-operated lifting device is designed to fully open the valve with 75% of set pressure under the valve disc in compliance with ASME Section VIII. For certain applications, the air operator may be designed to fully open the valve with no pressure at the valve inlet. An air-operated device can be operated from a remote point and can be used as a "drop out" valve. (A typical design is shown in Figure 41, and can be purchased from GE.)

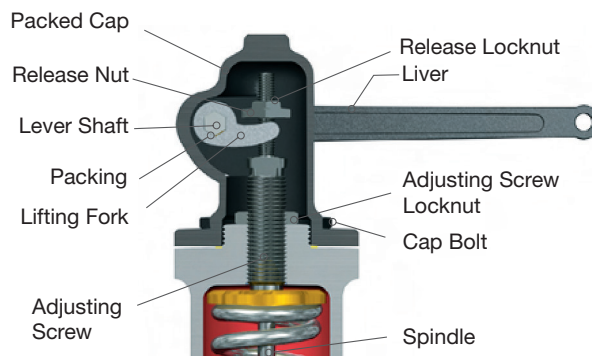

Figure 40: Packed Lever

XVII. Troubleshooting 1900 Series SRVs

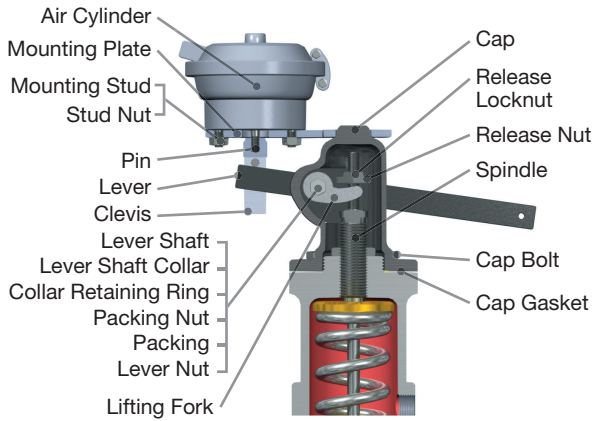

Figure 41: Air-Operated Packed Lever

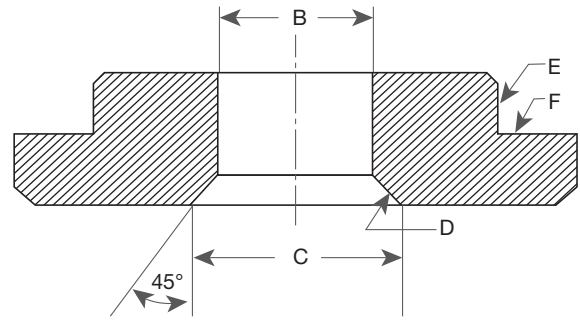

Figure 42: Lower Spring Washer

Table 19: Troubleshooting Seat Leakage, Simmer, and Chatter		
Malfunction	Cause	Solution
Seat Leakage	Damaged seats.	Rework seats or replace part.
	Improper installation.	Inspect installation, i.e., piping.
	Operating pressure too close to set pressure.	Increase differential.
	Excessive system vibration.	Recheck application.
	Misalignment of valve components.	Ensure valve is installed vertically. Ensure valve has been properly assembled.
	Debris trapped on seats.	Pop valve to clean seats. Rework seats.
Simmer	Damaged seats.	Rework seats or replace part.
	Wide nozzle seat.	Rework seat.
	Improper adjusting ring setting.	Check ring setting.
	Misalignment/binding.	Inspect valve and installation.
Chatter	Improper installation or valve sizing.	Check for piping restrictions. Check required capacity.
	Built-up back pressure.	Check outlet piping.
	Improper ring setting.	Check ring setting.

XVIII. 1900 Series Safety Relief Valve Options

A. General Information

Consolidated Type 1900 Flanged SRVs can be readily converted from conventional to bellows style, or vice versa, in the customer's repair shops. However, the Type 1901 and 1902 valves were constructed in the conventional type only. Table 20 shows the parts necessary for the typical conversion.

B. Conversion from Conventional to Bellows Type

ATTENTION!
Remove the bonnet plug (41) from the bellows valves (see Figure 7) and vent the bonnet (11) to a safe area.

Convert from a conventional to a bellows type valve as follows:

1. Remove the eductor tube (40) from the base (1) by selecting a drill bit approximately .016" (0.40 mm) smaller in diameter than the outside diameter of the eductor tube. Drill into the bore of the eductor tube where the tubing is attached to the base. This will reduce the tube wall thickness to the extent that it can easily be collapsed for removal. The bellows flange will cover the hole in the guide surface which will remain after the tube is removed.
2. Machine the existing lower spring washer (17) (see Figure 42 and Table 21).

Table 20: Conversion Parts: Conventional and Bellows Style Valves

Valve Orifice Size	New Parts to Convert From	
	Conventional to Bellows Valve	Bellows to Conventional Valve
D, E, F, G, H	<ol style="list-style-type: none"> 1. Bellows assembly - Standard Material, 316L Stainless Steel. 2. Set of gaskets for bellows valve. 3. Guide for bellows valve. 4. Disc holder for bellows valve. 5. Spindle for bellows valve (F, G and H only). 6. Spindle retainer for bellows valve. 7. Base studs for bellows valve (D, E, F and G only). 8. Machine existing lower spring washer (F, G and H orifices only). Upper spring washer, no change. 9. Drill .719" (18.26 mm) dia. on bonnet boss and tap 1/2" N.P.T. (as required) ⁽¹⁾ 	<ol style="list-style-type: none"> 1. Eductor tube for conventional valve. (Not required for UM valves.) 2. Set of gaskets for conventional valve. 3. Guide for conventional valve. 4. Disc holder for conventional valve. 5. Spindle for conventional valve (F, G and H only). 6. Spindle retainer for conventional valve. 7. Base studs for conventional valve (D, E, F and G only). 8. New lower spring washer for conventional valve (F, G and H orifices only). Upper spring washer, no change. 9. Bonnet vent plugged (if desired).

XVIII. 1900 Series Safety Relief Valve Options (Contd.)

Table 20: Conversion Parts: Conventional and Bellows Style Valves (Contd.)

Valve Orifice Size	New Parts to Convert From	
	Conventional to Bellows Valve	Bellows to Conventional Valve
K, L, M, Q, R, T, U	<ol style="list-style-type: none"> Bellows assembly - Standard Material, 316L Stainless Steel. Set of gaskets for bellows valve. Drill .719" (18.26 mm) dia. on bonnet boss and tap 1/2" N.P.T. (as required) ⁽¹⁾ Studs (1905-30 K and L, 1906-30 K and L only). 	<ol style="list-style-type: none"> Eductor tube for conventional valve. (Not required for UM valves.) Set of gaskets for conventional valve. Bonnet vent plugged (if desired). Studs (1905 K and L, 1906 K and L only).
Also J, N, P manufactured after 1981. ⁽²⁾		
J, N, P Manufactured before 1982. ⁽²⁾	<ol style="list-style-type: none"> Bellows assembly - Standard Material, 316L Stainless Steel. Set of gaskets for bellows valve. Guide for bellows valve. Disc holder for bellows valve. Drill .719" (18.26 mm) dia. on bonnet boss and tap 1/2" N.P.T. (as required). ⁽¹⁾ Studs (1905-30 N and P, 1906-30 N and P only). 	<ol style="list-style-type: none"> Eductor tube for conventional valve. (Not required for UM valves.) Set of gaskets for conventional valve. Bonnet vent plugged (if desired). Drill .438" (11.11 mm) dia. through guide flange 1.813 (46.04 mm) from guide bore centerline (J orifice only). Studs (1905 N and P, 1906 N and P only).
V, W	<ol style="list-style-type: none"> Bellows assembly. Set of gaskets for bellows valve. Disc holder for bellows valve. Guide for bellows valve. Lift restricting ring. Studs. 	<ol style="list-style-type: none"> Set of gaskets for conventional valve. Bonnet vent plug (if desired).

⁽¹⁾ Valves manufactured after 1980 are furnished with bonnet vent machined.

⁽²⁾ J, N, P orifice valves manufactured after 1981 are furnished with threaded disc holder and reduced guide bore for balanced bellows conversion.

XVIII. 1900 Series Safety Relief Valve Options (Contd.)

C. Conversion from Bellows to Conventional Type

Convert from a bellows to a conventional type valve as follows:

- Secure the eductor tube (40) in the base (1) by expanding or swaging into the hole provided. The upper end of the eductor tube should project above the guide surface of the base approximately .125" (3.18 mm) and the lower end should point directly and squarely toward the valve outlet. When the valve is assembled, the hole at the outer edge of the guide flange must fit loosely around the projection of the eductor tube.
- For F, G and H orifice valves only, machine the new lower spring washer (17) (see Figure 43 and Table 21).

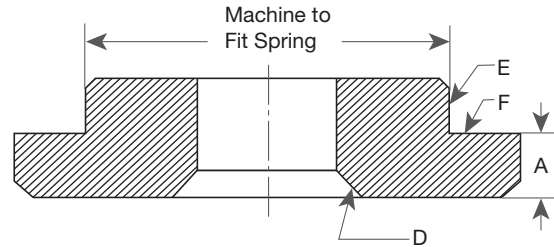

Figure 43: Lower Spring Washer F, G, and H Valves

ATTENTION!

For all 1900 Series SRVs, dimension A may not be less than specified in Table 21.

Table 21: Machining Conventional to Bellows Type Lower Spring Washer

Valve Type		B		C	
		in.	mm	in.	mm
1905F	1906F	.688	17.46	1.000	25.40
1910F	1912F				
1920F	1922F				
1905G	1906G				
1910G	1912G				
1920G	1922G				
1914F	1916G	.875	22.23	1.250	31.75
1924F	1926F				
1914G	1916G				
1918G	1924G				
1926G	1928G				
1918F	1928F	1.000	25.40	1.438	36.53
1905H	1906H	.688	17.46	1.126	28.60
1910H					
1920H	1922H				
1912H	1924H	.875	22.2	1.313	33.34
1914H	1916H	1.000	25.40	1.500	38.10
1926H					

Note: When indicated at surfaces D and E (see Figure 43), run out at surface F is not to exceed .005" (.127 mm) full indicator reading.

Table 22: Machining Bellows Type to Conventional Lower Spring Washer

Valve Type			A	
			in.	mm
1905-30F	1906-30F	1910-30F	.250	6.35
1920-30F	1922-30F	1905-30G		
1906-30G	1910-30G	1920-30G		
1905-30H	1906-30H			
1912-30F	1922-30G		.313	7.94
1910-30H	1920-30H			
1922-30H				
1914-30F	1916-30F	1924-30F	.375	9.53
1926-30F	1914-30G	1916-30G		
1918-30G	1924-30G	1926-30G		
1928-30G	1912-30H	1924-30H		
1918-30F	1928-30F			
1914-30H	1916-30H	1926-30H	.500	12.70

Note: When indicated at surfaces D and E (see Figure 43), run out at surface F is not to exceed .005" (.13 mm) full indicator reading.

XVIII. 1900 Series Safety Relief Valve Options (Contd.)

D. Optional Glide-Aloy™ Parts

Optional Glide-Aloy™ Parts and the Repair Processing of Such Components

Glide-Aloy™ is a proprietary process of GE utilized to provide a combination of a low coefficient of friction between sliding components and to protect the surfaces of the components to which the process has been applied. A Glide-Aloy™ surface-hardened valve component may be recognized by its flat, dull gray color and slick surface. The parent metal should not be visible on a new component.

ATTENTION!

Do not attempt to remove the coating of a Glide-Aloy™ treated component.

The Glide-Aloy™ reaction bonding process is commonly applied to Consolidated 1900 Series SRV disc holders and/or guides, when specified. Although the entire surface area of the component is treated, only the guiding surface is critical. When Consolidated 1900 Series SRVs contain Glide-Aloy™ parts, they may be identified by the coding found on the valve nameplate.

Example: 1905Jc-2-G1 where the “G” designation indicates Glide-Aloy™:

G1 - Glide-Aloy™ Holder

G2 - Glide-Aloy™ Guide

G3 - Glide-Aloy™ Holder and Guide

Glide-Aloy™ treated components may be cleaned by low-pressure compressed air, microbead blasting, or brushing. Also, a non-chlorinated, hydrocarbon shop solvent may be used. The latter is for personnel safety reasons and not because of any incompatibility between chlorides and Glide-Aloy™.

Regarding personnel safety, all personnel should be familiar with the appropriate processes as well as the material safety data sheets (MSDS) supplied by the vendor of any cleaning compounds used. Personal protective equipment (protective gloves, goggles, etc.) should be worn so as to avoid contact with materials that may be splashed during the cleaning process.

For a component in service after the cleaning process is completed, visually inspect parts to ensure all debris is removed, and that the components have the required finish.

GE's experience indicates that if the components have been properly cleaned, adequate coating will remain to ensure proper operation. The coating may appear lighter or missing in some areas, but the desired results will be achieved as a result of the coating characteristics imparted to the parent metal during the original coating process.

Components that are deeply gouged or galled, and that do not meet dimensional requirements, cannot be cleaned and returned to service. Machining removes the coating and renders the parts unacceptable. The surface-hardness approximates that of diamonds, and is approximately .002" (0.051 mm) thick.

ATTENTION!

Do not machine the guiding surfaces that have been Glide-Aloy™ treated.

ATTENTION!

Follow recommendations for safe handling of solvents as specified in the MSDS and observe safe practices for any cleaning method.

XIX. Maintenance Tools and Supplies

Table 23: Nozzle Bore Diameters											
Orifice		Original Nozzle ⁽¹⁾				New Nozzle ⁽¹⁾ (Std.& UM)				Nozzle Lap Handle ⁽²⁾	Ring Lap ⁽³⁾
		Nozzle Bore Diameter		Nozzle Lap Part No.	Nozzle Bore Diameter		Nozzle Lap Part No.				
Std.	UM.	in.	mm			in.		mm			
D-2	D	.393 to .398	9.98 to 10.11	543001	.404 to .409	10.26 to 10.39	4451501	544603	1672805		
E-2	E	.524 to .529	13.31 to 13.44	543002	.539 to .544	13.69 to 13.82	4451502	544601	1672805		
F	F	.650 to .655	16.51 to 16.64	543003	.674 to .679	17.12 to 17.25	4451503	544601	1672805		
G	G	.835 to .840	21.21 to 21.34	543004	.863 to .868	21.92 to 22.05	4451504	544601	1672805		
H	H	1.045 to 1.050	26.54 to 26.67	543005	1.078 to 1.083	27.38 to 27.51	4451505	544601	1672805		
J	J	1.335 to 1.340	33.91 to 34.04	543006	1.380 to 1.385	35.05 to 35.18	4451506	544601	1672805		
K	K	1.595 to 1.600	40.51 to 40.64	543007	1.650 to 1.655	41.91 to 42.04	4451507	544601	1672807		
L	L	1.985 to 1.990	50.42 to 50.55	543101	2.055 to 2.060	52.20 to 52.32	4451601	544601	1672807		
M	M	2.234 to 2.239	56.74 to 56.87	543102	2.309 to 2.314	58.65 to 58.78	4451602	544601	1672809		
N	N	2.445 to 2.450	62.10 to 62.23	543103	2.535 to 2.540	64.39 to 64.52	4451603	544601	1672809		
P	P	2.965 to 2.970	75.31 to 75.44	543104	3.073 to 3.078	78.05 to 78.18	4451604	544602	1672810		
Q	Q	3.900 to 3.905	99.06 to 99.19	543105	4.045 to 4.050	102.74 to 102.87	4451605	544602	1672812		
R	R	4.623 to 4.628	117.42 to 117.55	543106	4.867 to 4.872	123.62 to 123.75	4451606	544602	1672812		
T-4	T	N/A	N/A	N/A	6.202 to 6.208	157.53 to 157.68	4451608	544602	1672814		
U	U	N/A	N/A	N/A	6.685 to 6.691	169.80 to 169.95	None	None	1672814		
V	V	N/A	N/A	N/A	8.000 to 8.005	203.20 to 203.33	None	None	6267201		
W	W	N/A	N/A	N/A	10.029 to 10.034	254.74 to 254.86	None	None	4875201		

⁽¹⁾ After August 1978, all 1900 SRV Nozzles manufactured have increased bore diameter. The above chart shows how each orifice was affected. Nozzles - original vs. new - are interchangeable, but nozzle laps are not. On the outer diameter (O.D) of the new nozzles, the letter "C" is stamped. If this stamp becomes obliterated, the nozzle bore diameter must be measured to select the correct nozzle lap from above chart (see Table 23).

⁽²⁾ Nozzle lap handles are interchangeable between original and new nozzle laps.

⁽³⁾ Ring laps - One set of three (3) ring laps is recommended for each orifice to assure ample flat laps are available at all times.

XIX. Maintenance Tools and Supplies (Contd.)

A. Lapping Tools

The following tools are required for proper maintenance of Consolidated Safety Relief seats, and may be purchased from GE.

Nozzle Lap - The nozzle lap is used for lapping the nozzle seat and has one flat side, and one side with a 5° angle. This lap guides in the bore of the nozzle; therefore, a different size lap is required for each valve orifice.

Ring Lap - The ring lap is used for lapping the disc seat and finish lapping the nozzle seat.

Lapping Plate - The lapping plate is used for reconditioning the ring lap. It may also be used for lapping the disc (6). One 11" (279.40 mm) diameter plate is required for the entire line of valves (Part No. 0439004).

Lapping Compound - Lapping compound is used as a cutting medium when lapping the valve seats (see Table 24).

Brand	Grade	Grit	Lapping Function	Size Container	Part No.
Clover	1A	320	General	4 oz	199-3
Clover	3A	500	Finishing	4 oz	199-4
Kwik-Ak-Shun	----	1000	Polishing	1 lb 2 oz	199-11 199-12

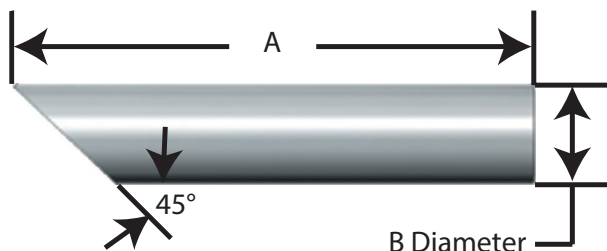

Figure 44: Drift Pins Specification

Drift Pins - Two drift pins are required for the removal of the disc (6) from the disc holder (8) (see Figure 43 and Table 25a).

Lifting Tools - Lifting tools are used for the removal of the upper internal parts of larger valves (see Table 25b).

Orifice	A		B		Part No.
	in.	mm	in.	mm	
D,E,F,G,H,J,K	1.75	44.5	.22	5.6	0430401
L,M,N,P	2.50	63.5	.38	9.5	0430402
Q,R	3.00	76.2	.63	15.9	0430403
T,U	3.50	88.9	.88	22.2	0430404

Orifice	Part No.
M, N	4464602

Spanner Wrench - Spanner wrench is used for the removal of the bellows from the disc holder (8) (see Table 26).

Valve Orifice	Description of Wrench				Pin Spanner Wrench No.
	Radius		Pin Dia.		
	in.	mm	in.	mm	
D, E, F	.750	19.05	.219	5.56	4451801
G	.750	19.05	.219	5.56	4451801
H	.875	22.23	.234	5.94	4451802
J	1.125	28.58	.266	6.76	4451803
K	1.250	31.75	.281	7.14	4451804
L	1.375	34.93	.297	7.54	4451805
M	1.625	41.28	.328	8.33	4451806
N	1.875	47.63	.359	9.12	4451807
P	1.875	47.63	.359	9.12	4451807
Q	2.500	63.50	.438	11.13	4451808
R	3.000	76.20	.500	12.70	4451809
T	3.750	95.25	.500	12.70	4451810
U	3.750	95.25	.500	12.70	4451810

XX. Replacement Parts Planning

A. Basic Guidelines

Use the following guidelines as reference for developing a replacement parts plan:

1. Classify the total number of valves in service by size, type, and temperature class.
2. Classify parts inventory by the tendency to require replacement.
 - Class I - Most frequently replaced
 - Class II - Less frequently replaced but critical in an emergency
3. Parts for the valve types covered by this manual are classified on Tables 27 and 28. "Qty. Parts" is the number of parts or sets recommended to achieve a desired need probability as it relates to the total number of valves in service by size and type. For example, a "Qty. Parts of 1" (25.4 mm) for "Valves in Service of 5" (127.00 mm) means that one part should be stocked for every five valves of the same type and size in service.
4. When ordering replacement parts, state the size, type, and serial number of the valve for which parts are required using correct nomenclature (see Figures 1 through 10).
5. Predicted availability indicates the percentage chance the user plant will have the right parts to make a proper repair (i.e., if Class I parts are stocked at the owner's facility, the parts needed to repair the valve in question will be immediately available in 70% of all instances).

B. Replacement Parts List

Consult the Recommended Spare Parts list (see Tables 27 and 28) to define the parts to be included in the inventory plan. Select the desired parts and determine those required for proper maintenance of the valve population in the plant.

C. Identification and Ordering Essentials

When ordering service parts, furnish the following information to ensure receipt of the correct replacement parts:

1. Identify valve by the following nameplate data:
 - Size
 - Type
 - Temperature Class
 - Serial Number
 - Example 1: 1.5" (38.10 mm) 1910Fc
S/N TD-94578
2. Specify parts required by:
 - Part Name (see Figures 1 through 10)
 - Part Number (if known)
 - Quantity

In addition, the serial number is stamped on the top edge of the outlet flange. Include the one or two letters preceding the figures in the serial number (see Figures 45 through 48).

Contact Parts Marketing: (318) 640-6044.

		Consolidated® Valve	
		Dresser, Inc. Subsidiary of General Electric Company	
		SIZE	
		CRN	
SERIAL NO		ASSEMBLER	
MANUF		ASSEMBLER	
TYPE			
SET PRESS		CDTP	
PRESS UNITS		BACK PRESS	
CAP		LIFT	
CAP UNITS		CAP UNITS	
MEDIA			

Figure 45: Typical Valve Nameplate

XX. Replacement Parts Planning (Contd.)

THIS VALVE CONTAINS AN	
O-RING SEAT SEAL	
○	O-RING MATERIAL
	O-RING PART NO.
	○

Figure 46: Typical Valve Nameplate

	PSV NUMBER	
	P. O. NUMBER	
	REQN NUMBER	
○		○

Figure 47: Optional Tag Number Nameplate

When the SRV is repaired, a metal repair nameplate (see Figure 48), Board “VR” symbol and stamp number, and the date of repair is permanently attached to the valve near the original nameplate. This repair nameplate may also contain information regarding altered set pressures, capacities, or blowdown, as applicable.

CERTIFIED BY	
Consolidated	
TYPE	
SIZE	SERIAL NO.
SET PRESS.	PSI
CDTP	PSI
○ TOTALBACK PRESSURE	PSITEMP.
°F ○	
CAP. LBS/HR	STD. CU. FT. / MIN. AIR
SAT. STEAM	
CAP. GPM	STD. CU. FT. / MIN. N.G.S.
WATER	
B/M	DATE

Figure 48: Repair Nameplate

ATTENTION!

To determine if the valve contains Glide-Aloy™ components (i.e., the disc holder (8) and/or the guide (9)), which are identified by the coding found on the valve nameplate, see Optional Glide-Aloy™ Parts.

XXI. Genuine Consolidated Parts

Each time replacement parts are needed, keep these points in mind:

- GE designed the parts
- GE guarantees the parts
- Consolidated valve products have been in service since 1879
- GE has worldwide service
- GE has fast response availability for parts

XXII. Recommended Spare Parts for 1900 Series SRVs

Table 27: 1900 Conventional and 1900-30 Bellows

1900 Conventional and 1900-30 Bellows with Liquid Trim (LA)

1900 Conventional and 1900-30 Bellows with Thermodisc (TD)

1900 Universal Media (UM) and 1900 UM -30 Bellows

Class	Part Name	C-conventional B-bellows	Qty. Parts/Same Valves in Service	Need Probability Coverage
I. Stocking Class I parts at the Qty. Parts column rate provides sufficient replacements for 70% of maintenance requirements	Disc (TD)	C and B	1/1	70%
	Disc (Std. & UM)	C and B	1/3	
	Nozzle (Std. & UM)	C and B	1/10	
	Limit Washer1 (Std. & UM)	C and B	1/1	
	Bellows (Std. & UM)	B	1/3	
	Adj. Ring Pin (Std. & UM)	C and B	1/3	
	Disc and Spindle Retainers (Std. & UM)	C and B	1 Set/1	
	Gasket (Set)			
	• Cap Gasket (Std. & UM)	C and B	1/1	
	• Bonnet Gasket (Std. & UM)	C and B	1/1	
	• Guide Gasket (Std. & UM)	C and B	1/1	
	• Adj. Ring Pin Gasket (Std. & UM)	C and B	1/1	
• Bellows Gasket (Std. & UM)	B	1/1		
II. Stocking Class II parts, in addition to Class I, at the Qty. Parts column rate provides sufficient replacements for 85% of maintenance requirements	Disc Holder (Std. & UM)	C and B	1/6	85%
	Spindle (Std. & UM)	C and B	1/6	
	Guide (Std. & UM)	C and B	1/6	
	Studs, Base (Std. & UM)	C and B	1 Set/6	
	Nuts, Base Stud (Std. & UM)	C and B	1 Set/6	

• For restricted lift valves only.

YOUR SAFETY IS OUR BUSINESS!!!

GE has not authorized any company or any individual to manufacture replacement parts for its valve products. When ordering replacement valve parts, please specify in your purchase order: "ALL PARTS MUST BE DOCUMENTED AS NEW AND SOURCED FROM GE."

XXII. Recommended Spare Parts for 1900 Series SRVs (Contd.)

Table 28: 1900 Conventional and 1900-30 Bellows with O-Ring Seat Seal Design (DA)

1900 Conventional and 1900-30 Bellows with O-Ring Seat Seal Design and Liquid Trim (DALA)

1900 Universal Media (UM) and 1900 UM -30 Bellows with Soft-Seat Design (UM DA)

Class	Part Name	C-conventional B-bellows	Qty. Parts/Same Valves in Service	Need Probability Coverage
<p>I. Stocking Class I parts at the Qty. Parts column rate provides sufficient replacements for 70% of maintenance requirements.</p>	O-Ring (Std.)	C and B	1/1	70%
	Teflon™ Seal (UM DA)	C and B	1/1	
	Disc (Std.: K-U only & UM DA)	C and B	1/10	
	O-Ring Retainer (Std.)	C and B	1/5	
	Soft-Seat Retainer (UM DA)	C and B	1/5	
	Retainer Lock Screw (Std. & UM)	C and B	1 Set/1	
	Limit Washer1 (Std. & UM)	C and B	1/1	
	Nozzle (Std. & UM)	C and B	1/5	
	Adj. Ring Pin (Std. & UM)	C and B	1/1	
	Gasket (Set)		1 Set/1	
	• Cap Gasket (Std. & UM)	C and B	1/1	
	• Bonnet Gasket (Std. & UM)	C and B	1/1	
	• Guide Gasket (Std. & UM)	C and B	1/1	
	• Adj. Ring Pin Gasket (Std. & UM)	C and B	1/1	
	• Bellows Gasket (Std. & UM)	B	1/1	
	Bellows (Std. & UM)	B	1/3	
	Disc Retainer (Std.: K-U only & UM)	C and B	1/1	
Spindle Retainer (Std. & UM)	C and B	1/1		
<p>II. Stocking Class II parts, in addition to Class I, at the Qty. Parts column rate provides sufficient replacements for 85% of maintenance requirements.</p>	Disc Holder (Std. & UM)	C and B	1/6	85%
	Spindle (Std. & UM)	C and B	1/6	
	Guide (Std. & UM)	C and B	1/6	
	Studs, Base (Std. & UM)	C and B	1 Set/6	
	Nuts, Base Stud (Std. & UM)	C and B	1 Set/6	

• For restricted lift valves only.

YOUR SAFETY IS OUR BUSINESS!!!

GE has not authorized any company or any individual to manufacture replacement parts for its valve products. When ordering replacement valve parts, please specify in your purchase order: "ALL PARTS MUST BE DOCUMENTED AS NEW AND SOURCED FROM GE."

XXIII. Manufacturer's Field Service, Repair and Training Program

A. Field Service

GE provides safe, reliable valve services through our Green Tag certified valve assemblers and repair centers. The first valve repair network of its kind and today's industry leader, our authorized Green Tag Centers have successfully served the valve market for over 25 years. Our services include:

Valve Survey

- Comprehensive, accurate record of all PRVs
- Identification of overlooked valves and valve interchangeability
- Product upgrades to reduce cost and improve performance

Inspection of the Valve & Installation

- Visual evaluation of the installation for compliance to codes and regulations
- Written evaluation covering compliance issues and discrepancies
- Expert recommendations and corrective actions

Testing

- On-site and in-place testing using the GE EVT* testing device
- High-capacity shop testing with steam, air or water
- Fully trained and certified pressure relief valve technicians
- Base line history established

Repair

- Audited facility with GE inspection criteria and critical dimensions
- Fully trained and certified pressure relief valve technicians
- Original manufacturer replacement parts

Inventory Control

- Global access to spare parts inventories
- Parts interchangeability
- Obsolete and excess inventory identification
- Recommend cost effective inventories

ValvKeep*

- Comprehensive computer-based valve management service
- Historical data storage and permanent record tracking
- Maintenance scheduling and planning
- Repair intervals validated by maintenance history of each valve
- Code Compliance
- Interfaces easily with enterprise or legacy systems

XXIII. Manufacturer's Field Service, Repair and Training Program (Contd.)

B. Factory Repair Facilities

The Repair Department, in conjunction with the manufacturing facilities, is equipped to perform specialized repairs and product modifications, e.g., butt-welding, bushing replacements, code welding, and pilot replacement.

For further information, please contact your local Green Tag Center.

C. SRV Maintenance Training

The rising costs of maintenance and repair in the utility and process industries indicate the need for trained maintenance personnel. GE conducts service seminars that help your maintenance and engineering personnel reduce these costs.

Seminars, conducted either at your site or ours, provide participants with an introduction to the basics of preventative maintenance necessary to minimize downtime, reduce unplanned repairs, and increase valve safety. While these seminars do not create "instant experts," they do provide the participants with hands-on experience with Consolidated valves. The seminar also includes valve terminology and nomenclature, component inspection, troubleshooting, setting, and testing with emphasis on the ASME Boiler and Pressure Vessel Code.

For further information, please contact your local Green Tag Center or the GE Consolidated Training Manager at +1 (281) 542-3646.

D. Self-Study Edition of the 1900 Series SRV

Maintenance Training Program is Available for Valve Shop Personnel

The Self-Study Program consists of a video tape that is integrated with a participant workbook. A participant begins with an introduction to the product and progresses through the various stages of disassembly, cleaning, maintenance repair, reassembly, setting, testing, installation, and conversions. The program can also be used as an instructor-led course. The training package includes:

- Five Participant Training Manuals
- Five Consolidated 1900 and 1900-30
- SRV Installation, Operation, and Maintenance Manuals
- Integral 1900 Series SRV video tape
- Coaches' Guide to facilitate learning

For all questions dealing with program kits, additional training and maintenance manuals, please contact your local Green Tag Center or the GE Consolidated Training Manager at +1 (281) 542-3646.

Notes

Notes

DIRECT SALES OFFICE LOCATIONS

AUSTRALIA

Brisbane
Phone: +61-7-3001-4319
Fax: +61-7-3001-4399

Perth

Phone: +61-8-6595-7018
Fax: +61-8-6595-7299

Melbourne

Phone: +61-3-8807-6002
Fax: +61-3-8807-6577

BELGIUM

Phone: +32-2-344-0970
Fax: +32-2-344-1123

BRAZIL

Phone: +55-19-2104-6900

CHINA

Phone: +86-10-5689-3600
Fax: +86-10-5689-3800

FRANCE

Courbevoie
Phone: +33-1-4904-9000
Fax: +33-1-4904-9010

GERMANY

Ratingen
Phone: +49-2102-108-0
Fax: +49-2102-108-111

INDIA

Mumbai
Phone: +91-22-8354790
Fax: +91-22-8354791

New Delhi

Phone: +91-11-2-6164175
Fax: +91-11-5-1659635

ITALY

Phone: +39-081-7892-111
Fax: +39-081-7892-208

JAPAN

Tokyo
Phone: +81-03-6871-9008
Fax: +81-03-6890-4620

KOREA

Phone: +82-2-2274-0748
Fax: +82-2-2274-0794

MALAYSIA

Phone: +60-3-2161-0322
Fax: +60-3-2163-6312

MEXICO

Phone: +52-55-3640-5060

THE NETHERLANDS

Phone: +31-15-3808666
Fax: +31-18-1641438

RUSSIA

Veliky Novgorod
Phone: +7-8162-55-7898
Fax: +7-8162-55-7921

Moscow

Phone: +7 495-585-1276
Fax: +7 495-585-1279

SAUDI ARABIA

Phone: +966-3-341-0278
Fax: +966-3-341-7624

SINGAPORE

Phone: +65-6861-6100
Fax: +65-6861-7172

SOUTH AFRICA

Phone: +27-11-452-1550
Fax: +27-11-452-6542

SOUTH & CENTRAL

AMERICA AND THE CARIBBEAN
Phone: +55-12-2134-1201
Fax: +55-12-2134-1238

SPAIN

Phone: +34-93-652-6430
Fax: +34-93-652-6444

UNITED ARAB EMIRATES

Phone: +971-4-8991-777
Fax: +971-4-8991-778

UNITED KINGDOM

Bracknell
Phone: +44-1344-460-500
Fax: +44-1344-460-537

Skelmersdale

Phone: +44-1695-526-00
Fax: +44-1965-526-01

UNITED STATES

Massachusetts
Phone: +1-508-586-4600
Fax: +1-508-427-8971

Corpus Christi, Texas

Phone: +1-361-881-8182
Fax: +1-361-881-8246

Deer Park, Texas

Phone: +1-281-884-1000
Fax: +1-281-884-1010

Houston, Texas

Phone: +1-281-671-1640
Fax: +1-281-671-1735

Visit us online at:

www.geoilandgas.com/valves

*Denotes a trademark of General Electric Company.

Other company names used in this document are the registered trademarks or trademarks of their respective owners.

© 2016 General Electric Company. All rights reserved.

GEA19379B

06/2016

