

41005 Series

Masoneilan* Cage Guided, Balanced Globe Valve
Instruction Manual

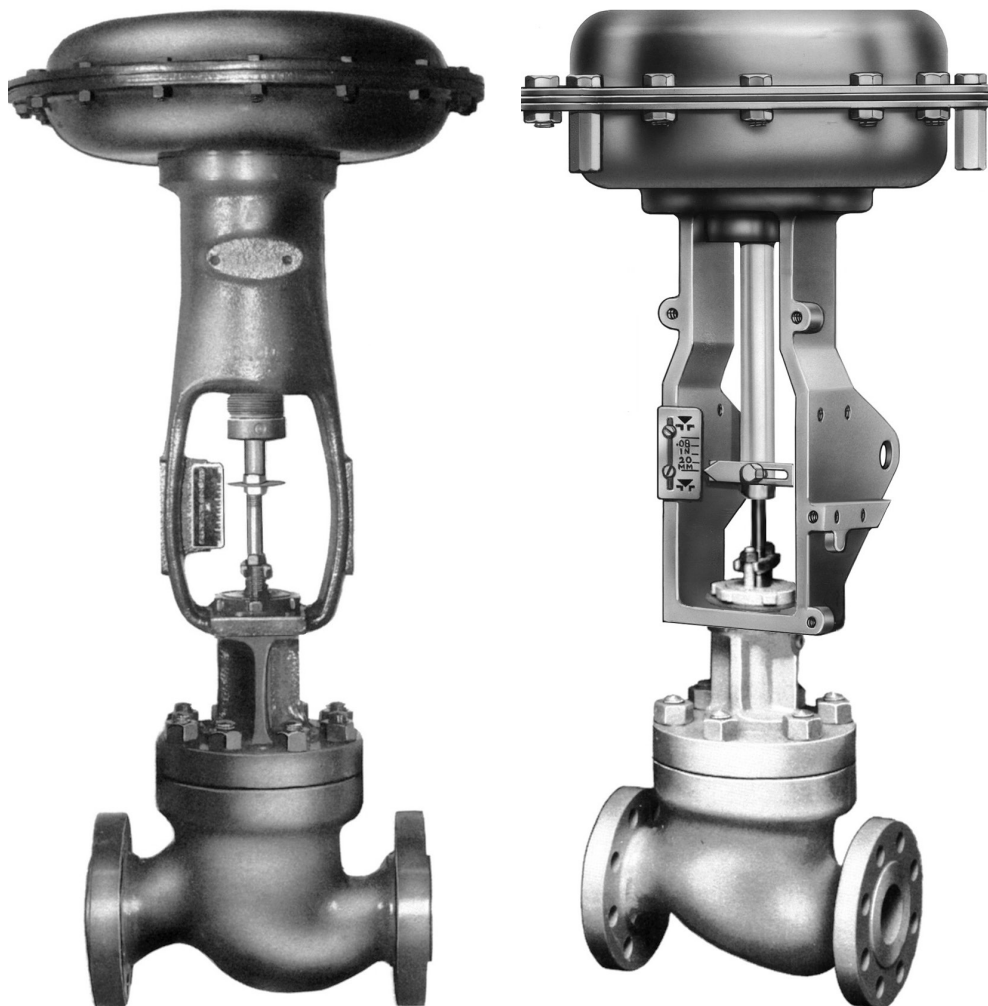

THESE INSTRUCTIONS PROVIDE THE CUSTOMER/OPERATOR WITH IMPORTANT PROJECT-SPECIFIC REFERENCE INFORMATION IN ADDITION TO THE CUSTOMER/OPERATOR'S NORMAL OPERATION AND MAINTENANCE PROCEDURES. SINCE OPERATION AND MAINTENANCE PHILOSOPHIES VARY, GE (GENERAL ELECTRIC COMPANY AND ITS SUBSIDIARIES AND AFFILIATES) DOES NOT ATTEMPT TO DICTATE SPECIFIC PROCEDURES, BUT TO PROVIDE BASIC LIMITATIONS AND REQUIREMENTS CREATED BY THE TYPE OF EQUIPMENT PROVIDED.

THESE INSTRUCTIONS ASSUME THAT OPERATORS ALREADY HAVE A GENERAL UNDERSTANDING OF THE REQUIREMENTS FOR SAFE OPERATION OF MECHANICAL AND ELECTRICAL EQUIPMENT IN POTENTIALLY HAZARDOUS ENVIRONMENTS. THEREFORE, THESE INSTRUCTIONS SHOULD BE INTERPRETED AND APPLIED IN CONJUNCTION WITH THE SAFETY RULES AND REGULATIONS APPLICABLE AT THE SITE AND THE PARTICULAR REQUIREMENTS FOR OPERATION OF OTHER EQUIPMENT AT THE SITE.

THESE INSTRUCTIONS DO NOT PURPORT TO COVER ALL DETAILS OR VARIATIONS IN EQUIPMENT NOR TO PROVIDE FOR EVERY POSSIBLE CONTINGENCY TO BE MET IN CONNECTION WITH INSTALLATION, OPERATION OR MAINTENANCE. SHOULD FURTHER INFORMATION BE DESIRED OR SHOULD PARTICULAR PROBLEMS ARISE WHICH ARE NOT COVERED SUFFICIENTLY FOR THE CUSTOMER/OPERATOR'S PURPOSES THE MATTER SHOULD BE REFERRED TO GE.

THE RIGHTS, OBLIGATIONS AND LIABILITIES OF GE AND THE CUSTOMER/OPERATOR ARE STRICTLY LIMITED TO THOSE EXPRESSLY PROVIDED IN THE CONTRACT RELATING TO THE SUPPLY OF THE EQUIPMENT. NO ADDITIONAL REPRESENTATIONS OR WARRANTIES BY GE REGARDING THE EQUIPMENT OR ITS USE ARE GIVEN OR IMPLIED BY THE ISSUE OF THESE INSTRUCTIONS.

THESE INSTRUCTIONS ARE FURNISHED TO THE CUSTOMER/OPERATOR SOLELY TO ASSIST IN THE INSTALLATION, TESTING, OPERATION, AND/OR MAINTENANCE OF THE EQUIPMENT DESCRIBED. THIS DOCUMENT SHALL NOT BE REPRODUCED IN WHOLE OR IN PART TO ANY THIRD PARTY WITHOUT THE WRITTEN APPROVAL OF GE.

Contents

1. General	5
1.2 Serial Plate	5
1.3 After Sales Service	5
1.4 Spare Parts	5
1.5 Actuator and Other Accessories	5
2. Numbering System	6
3. Installation	7
3.1 Cleanness of Piping	7
3.2 Isolating By-Pass Valve	7
3.3 Heat Insulation	7
3.4 Hydraulic Test and Cleaning of Lines	7
3.5 Flow Direction	7
4. Disassembly	8
4.1 Removal of Actuator	8
4.2 Opening of the Pressurized Chamber	8
4.3 Disassembly of Valve Plug Stem	9
4.4 Disassembly of the Auxiliary Pilot Plug	9
5. Maintenance – Repair	10
5.1 Packing Box	10
5.2 Repair of Parts	10
6. Valve Reassembly	12
6.1 Pinning the Valve Plug Stem	12
6.2 Assembly of Ring or Spring-Energized Seal Ring	13
6.3 41405 Valve Plug and Cage Assembly	14
6.4 Assembly of the Parts Inside the Valve Body	14
6.5 Assembly of Bonnet	14
6.6 Tightening of Body Stud Nuts	15
6.7 Assembly of Packing Box	16
7. Actuator	17
7.1 Coupling of Actuator Type 88 No. 6	17
7.2 Coupling of Actuator Type 87 No. 6	17
7.3 Coupling of Actuator Type 87 No. 10, 16 and 23	17
7.4 Coupling of Actuator Type 88 No. 10, 16 and 23	18
7.5 Coupling of Air-to-Extend Actuator (Type 37)	19
7.6 Coupling of Air-to-Retract Actuator (Type 38)	19
7.7 Other Types of Pneumatic Actuators	19
Body Sub Assembly	22

Safety Information

Important - Please Read Before Installation

Masoneilan 41005 Series instructions contain **DANGER**, **WARNING**, and **CAUTION** labels, where necessary, to alert you to safety related or other important information. Read the instructions carefully **before** installing and maintaining your control valve. **DANGER** and **WARNING** hazards are related to personal injury. **CAUTION** hazards involve equipment or property damage. Operation of damaged equipment can, under certain operational conditions, result in degraded process system performance that can lead to injury or death. Total compliance with all **DANGER**, **WARNING**, and **CAUTION** notices is required for safe operation.



This is the safety alert symbol. It alerts you to potential personal injury hazards. Obey all safety messages that follow this symbol to avoid possible injury or death.



Indicates a potentially hazardous situation which, if not avoided, could result in death or serious injury.



Indicates a potentially hazardous situation which, if not avoided, could result in serious injury.



Indicates a potentially hazardous situation which, if not avoided, could result in minor or moderate injury.



When used without the safety alert symbol indicates a potentially hazardous situation which, if not avoided, could result in property damage.

Note: Indicates important facts and conditions.

About this Manual

- The information in this manual is subject to change without prior notice.
- The information contained in this manual, in whole or part, shall not be transcribed or copied without GE's written permission.
- Please report any errors or questions about the information in this manual to your local supplier.
- These instructions are written specifically for the 41005 Series control valves, and do not apply for other valves outside of this product line.

Life Period

The current estimated useful life period for the Masoneilan 41005 Series control valve is 25+ years. To maximize the useful life of the product it is essential to conduct annual inspections, routine maintenance and ensure proper installation to avoid any unintended stresses on the product. The specific operating conditions will also impact the useful life of the product. Consult the factory for guidance on specific applications if required prior to installation.

Warranty

Items sold by General Electric are warranted to be free from defects in materials and workmanship for a period of one year from the date of shipment provided said items are used according to GE recommended usages. GE reserves the right to discontinue manufacture of any product or change product materials, design or specifications without notice.

Note: Prior to installation:

- The valve must be installed, put into service and maintained by qualified and competent professionals who have undergone suitable training.
- Under certain operating conditions, the use of damaged equipment could cause a degradation of the performance of the system which may lead to personal injury or death.
- Changes to specifications, structure, and components used may not lead to the revision of this manual unless such changes affect the function and performance of the product.
- All surrounding pipe lines must be thoroughly flushed to ensure all entrained debris has been removed from the system.

1. General

Important

This document contains all the instructions required for the installation, operation and maintenance of the equipment.

Regular maintenance, strict observance of these instructions and the use of manufacturer's replacement parts will guarantee optimum operation and reduce maintenance costs.

1.1 Scope

The following instructions are designed to guide the user through the installation and maintenance of the 41005 Series valves for all sizes and all pressure classes.

1.2 Serial Plate

The serial plate is usually fixed to the side of the actuator yoke. It indicates, amongst other things, the type of valve, the pressure class, the material used for the pressurized chamber and the air supply pressure of the actuator.

1.3 After Sales Service

GE offers its clientele an After Sales Service comprising highly qualified technicians, for the operation, maintenance and repair of its equipment. To benefit from this service, contact our local representative or the After Sales Service of the factory whose address is given at the end of the document.

1.4 Spare Parts

When carrying out maintenance operations, only manufacturer's replacement parts must be used, obtained through our local representatives or our Spare Parts Service.

When ordering spare parts, the model and serial numbers indicated on the manufacturer's serial plate must be given.

The recommended spare parts are indicated in the parts list included in this instruction manual on page 20.

1.5 Actuator and Other Accessories

The valve is equipped with an actuator; like all the other valve accessories, actuators are the subject of special instructions which provide information on the electric and pneumatic connections. The instruction manuals to be used for standard actuators are GEA31171 for types 37/38, GEA19530A for types 87/88.

2. Numbering System

Actuator (2 Digits)	Body S/A (5 Digits)				
Actuator Type and Action on Air Failure	Body Series	Balanced Plug Seal Type	Trim Type/Characteristic	Design Series	Optional Config.
Conventional 37 – Open 38 – Close Cylinder 51– Double Acting 52 – Open 53 - Close Multispring 87 – Open 88 – Close	41 Cage guided globe	0. Undefined 3. Pressure energized PTFE seal ring 4. With pilot 5. With seal ring 6. With PTFE seal 9. Graphite seal ring	0. Undefined 1. Standard cage/Linear 2. Standard cage/Equal percentage 3. Lo-dB*/anticavitation single stage/Linear/Equal % 4. Lo-dB* single stage with diffuser/Linear/Equal % 5. Lo-dB* double stage/Linear 6. VRT (stack) TYPE S/Linear 7. VRT (stack partial)/Type S/ modified percentage 8. VRT (cage) TYPE C/Linear 9. Anticavitation double stage/Linear (1)	5	A. Angle Body EB. Extension bonnet C. Cryogenic extension bonnet

Note: This instruction manual describes all the standard options in the 41005 Series valve. To satisfy the particular conditions of your application, GE may have had to develop a special option which is the subject of an additional clause to this instruction manual. In this case, the instructions given in the additional clause always take precedence over the general instructions.

3. Installation

3.1 Cleanness of Piping

Before installing the valve in the line, clean piping and valve of all foreign material such as welding chips, scale, oil, grease or dirt. Gasket surfaces must be thoroughly cleaned to insure leak-free joints.

3.2 Isolating By-Pass Valve

To allow for in-line inspection, maintenance and removal of the valve without service interruption, provide a manually operated stop valve on each side of the control valve and a manually operated throttling valve in the by-pass line.

3.3 Heat Insulation

In case of heat insulated installation, do not insulate the valve bonnet and take protection measures related to personal safety.

3.4 Hydraulic Test and Cleaning of Lines

During this operation, the control valve must not be used as an isolating valve.

This means that the valve must always be opened before carrying out pressure tests in the process line, cleaning of pipes, etc., otherwise equipment damages or destroying of seal rings could result.

3.5 Flow Direction

The valve must be installed so that the controlled substance will flow through the valve in the direction indicated by the flow arrow located on the body.

4. Disassembly

4.1 Removal of Actuator

(Figures 15 and 16)

Access to the internal components of the body should be accomplished with the actuator removed. To carry out this operation, follow the instructions below and refer to the specific actuator instructions, reference GEA19530A for a type 87/88 actuator and GEA31171 for the type 37/38 actuator.

4.1.1 Disconnection of instruments

Disconnect all mechanical couplings between the positioner and the other instruments on the one hand and the valve stem/actuator stem coupling on the other hand.

4.1.2 Plug stems screwed into the actuator stem

In the case of air-to-retract actuators, apply sufficient air pressure on the diaphragm to retract the stem completely.

Loosen the counter-nut, unscrew the stem.

CAUTION

During this operation, make sure that the plug does not turn when it is seated. If the plug travel is very small and there is a large amount of plug stem inside the actuator, it may be necessary to remove the yoke nut and lift the actuator so that the plug is not touching the seat.

4.1.3 Stems attached with a stem connector

In the case of air-to-retract actuators, apply sufficient air pressure on the diaphragm to retract the stem completely.

Loosen the screws and remove the stem connector.

4.1.4 Removal of actuator

Disconnect all the ingoing and outgoing air and electrical connections from the actuator. Loosen the yoke nut or attachment screws and lift the actuator, making sure that the concentricity and/or the thread of the bonnet is not damaged.

4.2 Opening of the Pressurized Chamber

(Figures 17, 18 and 19)

DANGER

Prior to disassembly, vent the process pressure and isolate the valve if necessary.

Note: The valve must always be reassembled with new packing rings and gaskets; before disassembly, make sure that the appropriate parts are available.

- A. Remove the packing flange nuts (3) then remove the packing flange (4) and the packing follower (23).
- B. Check that the exposed part of the valve plug stem (1) is clean enough for the bonnet (7) to be removed easily.
- C. Remove the body stud nuts (8).
- D. By means of a pad eye secured instead of the actuator, lift the bonnet (7) up and separate it from the valve body (18). During this operation, the valve plug stem (1) must be pushed downwards so that the valve plug remains in the valve body (18).
- E. Remove the spring washer (17) and the body gasket (10).
- F. In the case of type 41305, 41375, 41505, 41605 and 41905 valves, remove the valve plug stem (1) and valve plug (15) assembly from the cage by pulling the valve plug stem upward, then remove the cage (16) and "stack" (37) assembly for 41375 type valve.

CAUTION

Because of the cage gasket (31), the cage can sometimes be lifted along with the valve plug. If this should happen, press down on the cage so that it remains in the body. If the cage is lifted along with the valve plug, it could slip during handling and fall

In the case of a 41905 series valve [equipped with a graphite ring (45)], make sure that the ring is not damaged during the operation.

- G. In the case of a 41405 valve, remove the valve plug and body cage assembly by pulling the valve plug stem upward; in this case, the valve plug has a shoulder which prevents the cage from falling. Remove the valve plug from the cage by pulling on the end of the valve plug stem.
- H. Remove the seat ring (13) and the seat ring gasket (14) from the valve body (18).
- I. Remove the packing (6), the packing spacer (5) and the guide bushing (22) from the bonnet (7).

Note: A packing spacer (5) is only mounted when the bonnet has a side connection.

4.3 Disassembly of Valve Plug Stem

The valve plug stem is screwed and pinned into the valve plug (15).

To dismount the stem, the valve plug must be held as indicated below, taking care not to damage the guiding surfaces; the plug stem pin (9) is then removed. By means of flats or using a nut and counter-nut on the end of the stem, unscrew the stem taking care not to apply a bending moment which could deform it.

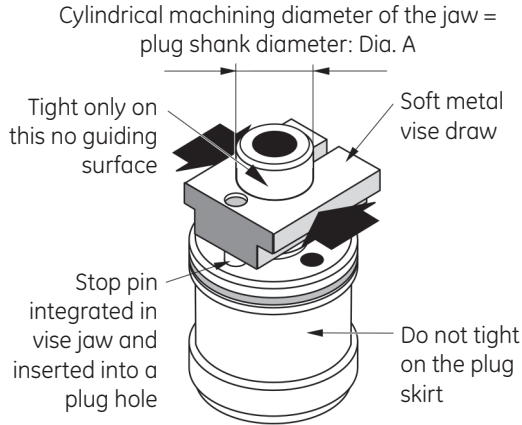

Figure 1

4.4 Disassembly of the Auxiliary Pilot Plug

When the valve is of the 41405 type.

In the case of 50, 80 or 100 mm (2", 3" or 4") valves (Figure 17).

Exert a sufficient force on the auxiliary pilot plug (20) to compress the spring washers (12). The retaining ring (19) can then be removed, releasing the auxiliary pilot plug and spring washers.

In the case of 150 to 400 mm (6" to 16") valves (Figure 17).

To carry out this operation safely, screws of the diameter and length indicated in the table in Figure 2 must be used. Thread the socket head cap screws through the holes in the auxiliary pilot plug (20). Tighten until the retainer ring (19) can be removed. Loosen the screws gradually. Remove the auxiliary pilot plug and the spring (12).

Valve size		Pilot Dismounting Screws Size			
mm	in.	Qty.	Length		Dia.
			mm	in.	
150	6	2	57	2.25	1/4" - 20 UNC 2A
200	8	2	70	2.75	3/8" - 16 UNC 2A
250	10	2	63.5	2.5	
300	12	3	101.5	4	
400	16	3	63.5	2.5	

Figure 2

5. Maintenance – Repair

5.1 Packing Box

Tightness of the packing box is obtained by compression of the packing (6). Compression must be achieved by evenly tightening the packing flange nuts (3) on the packing flange (4). Periodical retightening of the packing flange nuts is required to maintain tightness.

Make sure that the packing is not over tightened as this could prevent smooth operation of the valve. If a leak persists after the packing has been compressed to a maximum, the packing needs to be changed.

A packing spacer (5) is only mounted when the bonnet has a side connection.

5.1.1 Carbon/PTFE and pure PTFE packing rings

Carbon/PTFE and pure PTFE packing rings are cut in such a way that they can be replaced without having to separate the valve plug stem from the actuator stem.

- A. Unscrew and remove the packing flange nuts (3).
- B. Lift the packing flange (4) and packing follower (23) up along the valve stem.
- C. By means of a puller, remove the packing (6) and packing spacer (5), taking care not to damage the sealing surface of the packing box lantern or the valve plug stem.
- D. Replace the packing rings, with the cut in each ring placed about 120° from the next, pressing them down one at a time and respecting the table below:

Carbon/PTFE and pure PTFE packing box			
Number of rings			
N.D. mm (in.)	without side connection	with side connection	
		on top of packing spacer	under packing spacer
50 (2")	6	2	4
80 – 100 (3" – 4")	8	3	5
150 to 600 (6" to 24")	7	2	5

Figure 3

- E. Put the follower (23) and the packing flange (4) back on.
- F. Screw and tighten the packing flange nuts (3) without cramming the packing rings.

- G. Put the valve back into service and check for tightness. Tighten packing flange nuts (3) as required.

5.1.2 Graphite packing ring

To carry out this operation, the valve plug stem must be removed. See chapter on actuator disassembly.

- A. Loosen and remove packing flange nuts (3).
- B. Remove packing flange (4), and packing follower (23) from the plug stem.
- C. By means of a puller, remove packing rings (6), insuring not to damage the sealing surface of packing box or plug stem.
- D. Replace new packing set (6); first one back-up ring (Carbon/Graphite braided ring), then expanded graphite rings (smooth rings), at last, one other braided back-up ring; it is important to press the rings down one at a time in the packing box.

Number of packing set	Number of rings		
	N.D. mm (in.)	Braided	Graphite
50 (2")	1	4	1
80 – 100 (3" – 4")	1	6	1
150 to 600 (6" to 24")	1	5	1

Figure 4

- E. Put the follower (23) and packing flange (4) back on.
- F. Screw and moderately tighten the packing flange nuts (3).
- G. Reassemble the valve plug stem (see chapter on actuator re-assembly).
- H. Open and close the valve several times then tighten the packing.
- I. Put the valve back into service and check for tightness. Tighten packing flange nuts (3) as required.

5.2 Repair of Parts

Before re-assembly, the parts must be carefully examined in order to eliminate any scratched, worn or damaged parts.

5.2.1 Guiding surfaces

The guiding surfaces of the cage and valve plug, the guide bushing, and the guiding surfaces of the plug stem and auxiliary pilot plug must be checked in particular. If

there is only slight damage, a light abrasive can be used. Otherwise the part must be replaced as soon as possible (see paragraph "Spare parts").

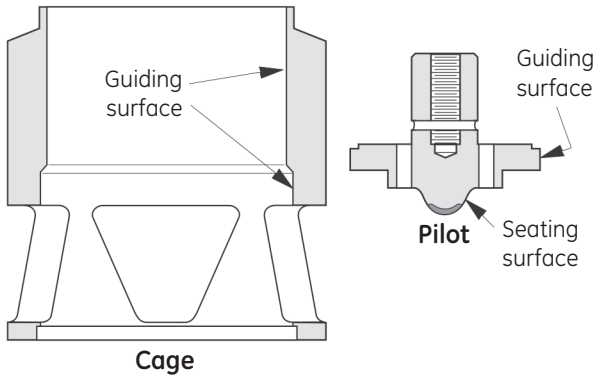

Figure 5

5.2.2 Sealing surfaces (Figure 6)

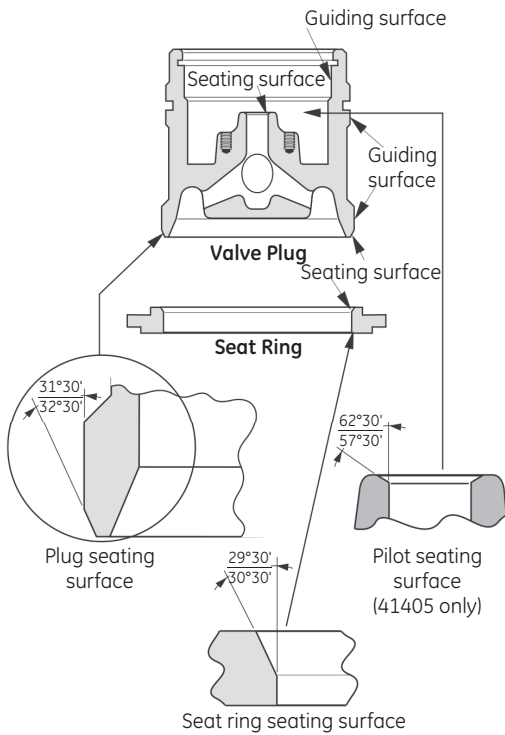

Figure 6

If the surface of the auxiliary pilot plug (20) is damaged, the auxiliary pilot plug must be replaced (see paragraph "Spare parts").

The seat ring (13), plug and auxiliary pilot plug (20) seating surfaces must be completely free of dents, wear and scratches.

If the auxiliary pilot plug seat in the valve plug (15) and/or other valve plug or seat ring seating surfaces show signs of slight deterioration, they can be touched up on a lathe.

However, not more than 0.25 mm (0.010") of metal must be removed in the case of a 50, 80 or 100 mm (2", 3" or 4") valve or more than 0.4 mm (0.015") in the case of a 150 to 400 mm (6" to 16") valve. Make sure that the seating angle indicated in Figure 6 is respected.

If a slight defect exists on any of the above seating surfaces, lapping can be envisaged, in which case the following must be respected:

- Spread a fine layer of high quality sealing compound on the seating surface.
- Put the seat ring (13) in the body, noting the angle.
- In the case of 41305, 41505, 41605 and 41905 valves, put the cage (16) on the seat ring.
- In case of 41375 valves, put the stack (48) on the seat ring and the cage (16) on the stack.
- In the case of 41405 valves, assemble the valve plug, cage and stem (15)-(16)-(1).
- In case of 41305, 41505, 41605, 41375 and 41905, assemble the valve plug (15) and stem (1).
- Assemble the bonnet (7) and its guide bushing (22).
- Place an appropriate tool on the valve plug stem (1) to turn it.
- Lap by slightly rotating the valve plug or the auxiliary pilot plug in alternative directions. After several rotations, lift the valve plug, turn it 90°, and start again.
- Lapping can be repeated, but must be limited as much as possible so that the seat remains sufficiently narrow to guarantee tightness.
- Disassemble the parts, clean them and put them back, respecting the initial angle.

5.2.3 Gasket seating surfaces

Gasket seating surface must be free of dents, scratches and corrosion; otherwise, they will need to be repaired.

5.2.4 Seal rings and gaskets

Spiral-wound gaskets (10), (14) and (36) must always be changed after disassembly. Seal rings (11A), (11C) or (11E) can be reused if they are free of scratches, erosion and corrosion.

5.2.5 Valve plug, valve plug stem

If the valve plug has to be changed, then the stem must also be completely changed to guarantee correct pinning of the assembly. If only the valve plug stem has to be changed, then the valve plug can be reused.

6. Valve Reassembly

6.1 Pinning the Valve Plug Stem

The valve plug (15) and stem (1) assembly consists of a rod threaded into the valve plug and pinned in place.

If the valve plug (15) [or the auxiliary pilot plug (20) in the case of a 41405 valve] needs to be replaced, it is recommended using a new stem. The hole of the original pin in an old stem often prevents satisfactory results being obtained and can seriously impair the mechanical strength of the stem-valve assembly.

Assembly is carried out as follows:

6.1.1 Reference marking on the valve plug stem

Make a reference mark on the valve plug stem at a distance "X" (Figures 7 and 8), equivalent to the stem recess in the valve plug.

Note: For shouldered plug stems with two flats, the above marking is unnecessary.

6.1.2 Tightening of the plug stem

To carry out this operation, the valve plug must be prevented from moving by holding the plug shank with an appropriate tool.

Screw two nuts on to the end of the new plug stem and lock them together. Screw the valve plug stem solidly into the plug, checking that the reference mark is level with the end of the plug shank.

If the stem has flats, apply a torque "T" using a wrench of dimension "E" (see Figure 7).

6.1.3 Drilling the pin hole (Figures 7 and 8)

Note: For this operation, it is recommended clamping the valve plug-stem assembly by the plug shank to avoid damaging the guiding surfaces; particular care must be taken so that the pin hole goes through the valve plug axis.

If the valve plug is new, drill a hole of diameter "C" at a distance "D" from the end of the valve plug; choose the diameter "C" from the table according to the type of pin used (metric or Anglo Saxon pin).

If the hole is already drilled in the valve plug, use the hole as a guide to drill through the valve plug stem.

Valve plug stem diameter B	Diameter A	Metric pin, diameter C	Anglo-Saxon pin dia. C	F	D	Distance X	E	Torque T	
								Non-Shouldered stem	Shouldered stem
mm (in.)	mm (in.)	mm	In.	mm (in.)	mm (in.)	mm (in.)	mm (in.)	N.m (Ft.lbs)	N.m (Ft.lbs)
12.7 (1/2)	20 (.79)	3.5	0.14	18 (.70)	18.5 (.73)	6 (.24)	17 (11/16)	50 (37)	60 (44)
15.87 (5/8)	25.5 (.98)	5.0	0.2	24 (.95)	28 (1.1)	8 (.30)	22 (7/8)	50 (37)	160 (118)
19.05 (3/4)	35 (1.38)	5.0	0.2	30 (1.2)	45 (1.77)	19 (.75)	27 (11/16)	160 (118)	160 (118)
25.4 (1.0)	44.5 (1.66)	8.0	5/16	40 (1.58)	47.5 (1.88)	25 (.98)	30 (11/4)	160 (118)	250 (184)
31.75 (1 1/4)	58 (2.28)	8.0	5/16	55 (2.20)	70 (2.76)	31.5 (1.24)	40 (1 5/8)	-	800 (590)
38.1 (1 1/2)	70 (2.76)	10.0	-	65 (2.56)	90 (3.54)	33 (1.30)	50 (2)	-	1 500 (1100)

Figure 7

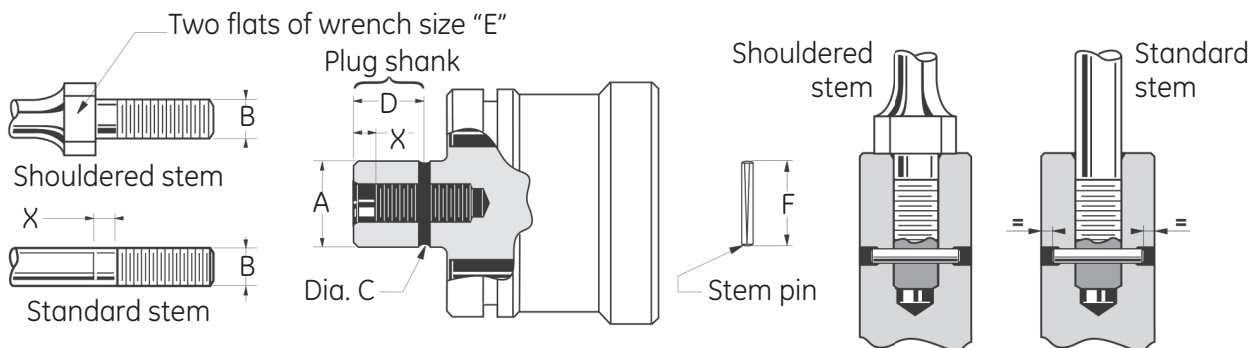

Figure 8

6.1.4 Pinning

By means of a hammer, introduce the pin into the hole. Complete the pinning operation, taking care to ensure that the pin is recessed by the same amount at both sides.

Using a ball tooling and hammer, caulk the pin hole edge of the plug.

Place the assembly in the soft jaw chuck of a lathe to check alignment of the two parts; correct any alignment defects.

6.2 Assembly of Ring or Spring-Energized Seal Ring

6.2.1 41305 valve

(Figures 9, 18 and 19)

These valves have a spring-energized seal rings composed of a PTFE-based jacket maintained expanding by a spring.

To insert the ring into the plug groove:

- Lubricate the entry chamber.
- Place the ring over the conical top of the plug so that the lips of the ring face to the pressure (see Figure 9).

CAUTION

To the assembly direction of the radial ring (11F) on the plug (see Figure 9).

Flow Tends to Open: the open side is in the top.

Flow Tends to Close: the open side is in the lower part.

- Slip to the ring into the groove (without spinning it) as shown in Figure 9. This operation can be facilitated by heating the ring. The temperature of the ring should not exceed 150°C.
- Keep the ring retained until it returns to room temperature and goes back in place within the groove. Clamping with a collar (SERFLEX type) will help to properly position the ring.

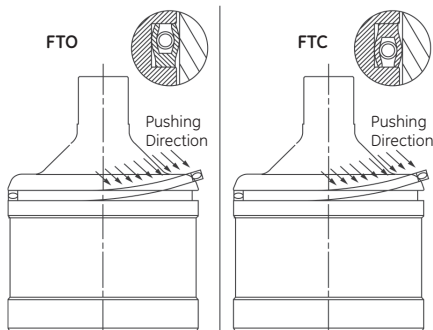

Figure 9

6.2.2 41405 and 41505 valves

(Figures 17 and 19)

These valves are equipped with metal rings; the inner ring has a straight cut while the outer ring has a staggered cut.

To insert the rings into the cage groove, open the rings slightly by hand and slide them, one after the other, along the plug making sure that the parts are not damaged.

Note: The cuts in the outer and inner rings are to be placed at about 180° from each other.

6.2.3 41605 valve

(Figure 19)

These valves are equipped with an inner elastomeric ring and a PTFE gasket.

Insert the elastomeric ring (11D) in the groove.

Place the PTFE gasket (11C) at a temperature of 100°C (boiling water) to 160°C for a few minutes to facilitate insertion, then slide along the plug until it slips into the groove.

For optimum insertion of the ring, a Serflex type ring compressor can be used to compress the ring in the groove for several minutes.

6.2.4 41905 valve

(Figure 19)

These valves are equipped with rings; the inner metal ring has a straight cut and the outer ring is made of graphite.

The new graphite seal ring (11A) is supplied in the form of a closed ring in which a notch must be cut before being inserted.

CAUTION

Graphite seal rings are fragile and the following operations must be carried out very carefully.

Using a sharp blade, carry out two V notches on the two opposite faces. Hold the ring on either side of the notch between the thumb and index and bend until it breaks.

Using a very fine file, adjust each end of the ring so that its external circumference corresponds to the internal circumference of the inside diameter of the cage (16).

To adjust the length of the ring correctly, insert the new graphite ring into the cage, with the ring against the inner wall of the hole in the cage, allowing minimum play between the two ends of the ring.

To insert the inner ring, then the graphite ring into the

cage groove, slightly open the rings by hand and slide them one after the other along the plug, taking care not to damage the parts.

Note: The cuts on each ring are to be placed at about 180° from each other.

6.2.5 41375 high temperature valve (232°C to 316°C) (Figure 19)

These valves are equipped with a seal ring composed of a jacket and a metallic spring and two backup rings (11G).

Assemble the different parts as shown in Figure 19, starting by the backup rings.

CAUTION

Put these parts as shown in Figure 19, the angle of 90° of the backup ring in front of the extrusion gap between cage and plug.

6.3 41405 Valve Plug and Cage Assembly (Figure 17)

6.3.1 Assembly of valve plug and auxiliary pilot plug

Assemble, as appropriate, the flat spring or the coil springs then the valve plug/plug stem assembly.

Using the same tools as those used for disassembly (see chapter "Disassembly"), compress the springs so that the retaining ring can be inserted in the groove of the main plug.

6.3.2 Assembly of cage

Place the cage over the valve plug assembly via the top of the plug stem. When doing so, take particular care to position the ring correctly.

6.4 Assembly of the Parts Inside the Valve Body (Figures 17, 18 and 19)

Proceed as follows:

- After checking that the surfaces are perfectly clean, place the seat gasket (14) in the valve body, making sure that it is centered as well as possible.
- Mount the seat ring or the diffuser seat (13).
- Mount:
 - The cage (16) for 41305, 41605 and 41905 valves,

- The cage/plug/stem assembly for 41405 valves,
- The STACK assembly (making sure that the face with the smallest number of holes is in contact with the seat ring), and cage (16) for 41375 valves.

CAUTION

For the double-cage assembly, carry out the following operations:

- Put the inner cage (16) upside down,
- Encase the outer cage (75) on the inner cage, maintain them together with the two pins (76).
- In the case of valves other than 41405 valves, insert the valve plug/stem/ring assembly into the cage taking particular care as it goes past the ring or spring-energized seal ring.
- In the case of valves with a N.D. less than 150 (6"), place the body/cage gasket in the valve body, making sure that it is centered as well as possible.
- For valve sizes 150 to 400 mm (6 to 16"), insert either the cage gasket (24) or the flat spring washer (17).
- For valve sizes 450, 600 and 750 mm (18, 20 and 24"), insert either the first cage gasket, the cage washer and the second cage gasket or the flat spring depending on the type of valve, then place the body gasket (10) in the valve body making sure that it is centered as well as possible.

CAUTION

To the direction of assembly of spring washer:

- ND 150 (6") to 450 (18") valves, the concave face is upwards,
- ND 500 (20"), and 600 (24"), the concave face is downwards and the tapped holes are visible.

6.5 Assembly of Bonnet

Check that the packing ring (6), the spacer (5) and the guide bushing (22) have been removed from the bonnet.

Position the bonnet (7) above the valve, so that the packing flange studs (2) are perpendicular to the flow direction of the valve.

Thread the bonnet (7) onto the valve stem (1) and push it down carefully until it goes into the valve body studs (21) and takes up its correct position.

Grease the threads of the valve body studs (21) and the bearing surfaces of the body stud nuts (8).

Screw on the body stud nuts by hand. Tighten the nuts lightly and evenly so that the internal parts are held in place. The face of the bonnet should be parallel to the upper face of the body.

Slide the guide bushing (22) onto the valve plug stem and let it drop to the bottom of the packing box housing.

6.6 Tightening of Body Stud Nuts

Alignment of internal parts

In order to achieve perfect alignment of the seat ring and the valve plug, a force must be applied to the plug stem during tightening of the bonnet which results in correct relative positioning of the two parts.

The force can be applied with the pneumatic actuator as follows:

Place the actuator on the valve bonnet (7) by means of the yoke nut (33) or attachment screws and connect the valve plug stem to the actuator stem. See chapter on actuators for installation instructions.

CAUTION

During this operation, make sure that the plug does not turn when it is seated. If the plug travel is very small and there is a large amount of plug stem inside the actuator, it may be necessary to remove the yoke nut and lift the actuator so that the plug is not touching the seat.

Align the internal parts as follows:

In the case of air-to-extend actuators, supply air to the actuator at the maximum pressure indicated on the serial plate and in the case of spring-to-extend actuators, do not supply air to the actuator, so that the optimum positioning of the valve plug and seat can be obtained.

Single bolting circle:

Evenly tighten the nuts (8) by applying the torque indicated in table in Figure 10 and the tightening sequence in Figure 11.

Double bolting circle:

Beginning by the internal nuts, manually screw all the bolts. Screw the internal nuts in order indicated by the Figure 2 and screw them by successive, uniform and progressive levels. During the tightening, make sure that the bonnet face stays parallel at that of the body. When the torque values given in the following table are reached, the bonnet face must be in contact with that

of the body. Screw the external nuts in order indicated by the Figure 2 and screw them by successive, uniform and progressive levels until the torque values given in the following table.

Torque Valve body stud/Bonnet					
Body		Nuts (21)		Torque	
Nominal size (in)	ASME Pressure classe	Size (in)	No.	m.N	ft.lb
2 3 x 2 4 x 2	300/600	3/4 - 10	6	150	110
	900/1500	7/8 - 9	8	250	180
2	2500	1 1/4 - 8	6	550	410
	900/1500	1 - 8	8	400	300
3 4 x 3 6 x 2	300/600	3/4 - 10	8	150	110
	900 / 1500 900/1500	1 1/4 - 8	6	800	600
3	2500	1 1/2 - 8	6	1050	775
4 6 x 4 8 x 4	300/600	7/8 - 9	8	250	180
	900	1 1/2 - 8	6	1200	900
	1500	1 1/2 - 8	6	1400	1000
4	2500	1 5/8 - 8	8	1250	930
6 8 x 6 10 x 6	300	1 - 8	8	400	300
	600	1 - 8	12	350	250
	900/1500	1 3/4 - 8	8	1800	1300
6	2500	1 7/8 - 8	8	1900	1400
8 10 x 8 12 x 8	300/600	1 1/4 - 8	8	700	500
	900	1 3/4 - 8	8	1900	1400
	1500	1 3/4 - 8	8	2300	1700
8	2500	1 3/4 - 8	12	1650	1220
10	300	1 1/2 - 8	8	1200	900
	600	1 1/2 - 8	12	1200	900
	900	1 3/4 - 8	12	1800	1300
	1500	1 3/4 - 8	12	2000	1500
	2500	2 - 8	12	2800	2070
12 16 x 12	300	1 1/2 - 8	8	1300	950
	600	1 1/2 - 8	12	1200	900
	900	1 1/2 - 8	16	1200	900
	1500	1 3/4 - 8	16	2000	1500
12	2500	1 7/8 - 8	20	2200	1630
16	300	1 1/2 - 8	12	1300	950
	600	1 1/2 - 8	16	1300	950
	900	1 1/2 - 8	20	1400	1000
	1500	1 3/4 - 8	20	2300	1700
	2500	2 - 8	24	2650	1960
20	300	1 3/8 - 8	24	900	650
	600	1 3/4 - 8	24	2000	1500
	900	1 7/8 - 8	24	2700	2000
24	300	1 3/4 - 8	20	1900	1400
	600	1 3/4 - 8	26	2200	1600
30	300	1 3/4 - 8	28	2000	1500

Figure 10

6.7 Assembly of Packing Box

To assemble the packing box, proceed as indicated in the "maintenance" chapter, paragraph 5.1.1 or 5.1.2.

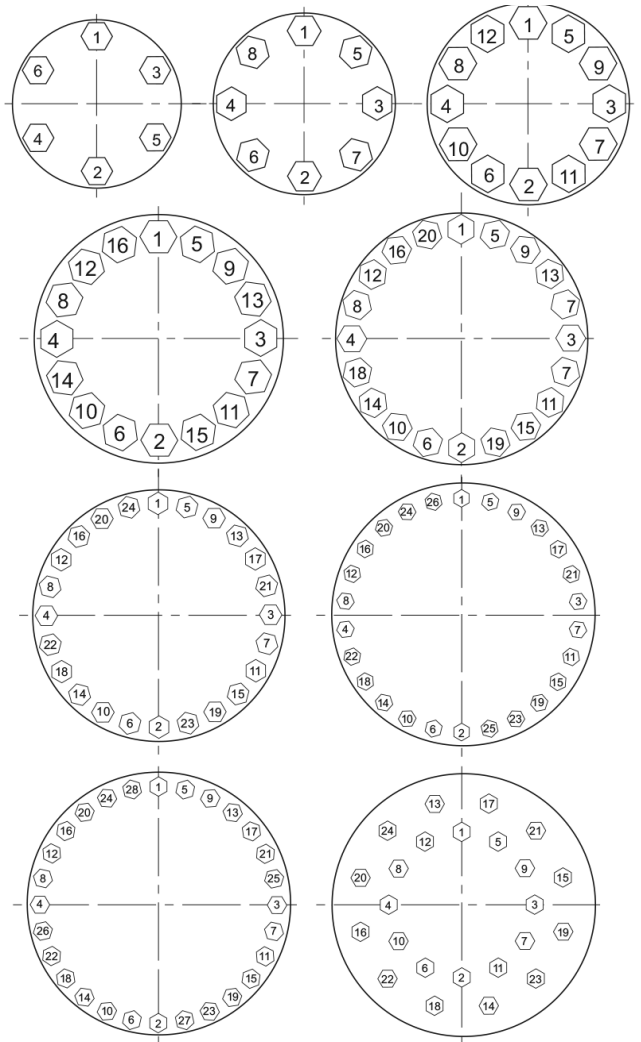

Figure 11. Tightening sequence of nuts (8)

7. Actuator

CAUTION

For coupling operations of actuators on valves, it is necessary as a preliminary:

- to position the plug (15) on its seat ring (13). (In no case, one should not turn the plug on its seat, to avoid any deterioration of tightness seat).
- connect a temporary air supply line to the actuator.

7.1 Coupling of Actuator Type 88 No. 6

(Figure 15)

- A. Tighty screw the two hex nuts (1) onto the plug stem.
- B. Push down the actuator and, at the same time, screw on the yoke nut (33), then the bottom stem connector (2). As soon as it becomes possible, insert the valve stem into the actuator stem. The stem must be inserted far enough so that when there is no air in the actuator, the valve plug does not touch the seat.
- C. Tighten the yoke nut.
- D. Unscrew the valve plug stem until the valve plug comes into contact with the seat. Do not turn the valve plug on the seat as this could damage the sealing surfaces.
- E. Supply air to the actuator until the stem has travelled at least 10 mm.
- F. Unscrew the plug stem the number of turns N1 specified in Figure 13.

CAUTION

In the case of 41405 valves, use the N2 valve so ensure tightness of the pilot plug.

- G. Screw the 2 nuts (1) as far as they will go and check that operation is correct.
- H. Use the pointer (7) to set the travel scale (9) to the closed valve position.

7.2 Coupling of Actuator Type 87 No. 6

(Figure 15)

- A. Tighty screw the two hex nuts (1) onto the plug stem.
- B. Push down the actuator and, at the same time, screw on the yoke nut (33), then the bottom stem connector (2). As soon as it becomes possible, insert the valve stem into the actuator stem. The stem must be inserted far enough so that, when there is air in the

actuator, the valve plug does not touch the seat.

- C. Tighten the yoke nut.
- D. Supply air to the actuator at the initial pressure of spring range.
- E. Use the pointer (7) to set the travel scale (9) to the open valve position.
- F. Supply the actuator with air at a high enough pressure to obtain a travel equal to the nominal travel of the valve.

CAUTION

In the case of the 41405 valves, reduce the travel by value A indicated in Figure 14.

- G. Unscrew the plug stem until the valve plug is in contact with the seat. Do not turn the valve plug on the seat as this could damage the sealing surfaces.
- H. Screw the 2 nuts (1) as far as they will go and check that operation is correct.

7.3 Coupling of Actuator Type 87 No. 10, 16 and 23

(Figure 15)

- A. Tighty screw hex nut (1) onto the plug stem.
- B. Screw the top stem connector assembly tightly onto the actuator stem.
- C. Push down the actuator and, at the same time, screw on the yoke nut (33), then the bottom stem connector assembly by screwing until they come into contact with the hex nut (1).
- D. Push down the actuator and tighten the yoke nut.
- E. Supply the actuator with air at the initial pressure indicated on the spring scale.
- F. Position the stem connector assembly at distance "X" indicated in Figure 12.
- G. Use the pointer (7) to set the travel scale (9) to the open valve position.
- H. Supply the actuator with air at a high enough pressure to obtain a travel equal to the nominal travel of the valve

CAUTION

In the case of the 41405 valves, reduce the travel by value A indicated in Figure 14.

- I. With the plug correctly positioned on the seat, unscrew the bottom stem connector assembly until it comes into contact with the top stem connector. Tighten the socket head cap screws (5), nuts (1) and (32) and check that operation is correct.

Actuator No	Travel		"X" Actuator 87		"X" Actuator 88	
	mm	inches	mm	inches	mm	inches
10	20	0.8	130	5.12	117.3	4.62
10	38	1.5	138.2	5.44		
16	20	0.8	203.2	8.00	178.3	7.02
16	38	1.5	228.6	8.50		
16	51	2.0	235.7	9.28		
16	63.5	2.5	241.3	9.50		
23	20	0.8	209.5	8.25		
23	38	1.5	218.9	8.62		
23	51	2.0	231.6	9.12		
23	63.5	2.5	243.6	9.59		

Figure 12. Position of top stem connector

7.4 Coupling of Actuator Type 88 No. 10, 16 and 23

(Figure 15)

- A. Tightly screw hex nut (1) onto the plug stem.
- B. Tightly screw the top stem connector assembly onto the actuator stem.
- C. Push down the actuator and, at the same time, screw on the yoke nut (33), then the bottom stem connector assembly by screwing until they come into contact with the hex nut (1).
- D. Push down the actuator and tighten the yoke nut.
- E. Unscrew the top stem connector to respect dimension "X" in Figure 12.
- F. With the plug correctly positioned on the seat, unscrew the bottom stem connector assembly to bring it into contact with the top stem connector.
- G. Supply air to the actuator until the stem has travelled at least 15 mm.
- H. Unscrew the bottom stem connector the number of turns N1 specified in Figure 13 then lock manually with hex nut (1).

CAUTION

For 41405 valves, use the N2 valve so ensure tightness of the pilot plug.

- I. Release the pressure in actuator so that the two parts of connector come into contact and tighten the socket head cap screws and nuts (1) and (32).
- J. Shut off the supply pressure in the actuator and use the pointer (7) to set the travel scale (9) to the closed valve position and check that operation is correct.

Valve size (in)	ASME class	Plug stem diameters mm (in)	N1 (turn)	N2 41405 (turn)	a mm (in)
2	150, 300 or 600	12.7 (1/2")	1.5	3.5	1.9 (0.075)
3	2500				
2	900 to 2500			3.25	
3 and 4	150 to 1500	15.87 (5/8")	1.5	3.5	2.0 (0.08)
4 and 6	2500				
6	150 to 1500	19.05 (3/4")	1.25	4.25	2.0 (0.08)
8	2500				
8	150 to 1500	25.4 (1")	1.25	4.5	2.3 (0.09)
10	2500				
10, 12 and 16	150 to 1500				
12 and 16	2500				
18	150 to 1500				
20	150 to 900				
24	150 to 600				
				—	

Figure 13. Reverse actuators – seating values for 41305 – 41505 – 41605 – 41905 valves

Valve size (in)	ASME class	Value A mm (in)	Value a1 mm (in)
2	150, 300 or 600	2.5 (0.1)	4.4 (0.17)
3	2500		
2	900 or 2500	2 (0.08)	3.9 (0.15)
3 and 4	150 to 1500	3 (0.12)	5 (0.2)
4 and 6	2500		
6	150 to 1500	5 (0.2)	7 (0.27)
8	2500		
8	150 to 1500	6 (0.24)	8.3 (0.33)
10	2500		
10, 12 and 16	150 to 1500	7 (0.275)	9.3 (0.37)
12 and 16	2500		
18	150 to 1500		

A = Pilot plug travel

Figure 14. Seating value for 41405 valves

7.5 Coupling of Air-to-Extend Actuator (Type 37)

(Figure 16)

- Push down on the plug stem (1) until the plug rests is seated.
- Attach the actuator to the valve bonnet with the yoke nut (33) or attachment screws. Apply a sufficient pressure to the diaphragm to extend the actuator stem by the normal valve travel for valves 41305, 41505, 41605 and 41905 and the travel minus the value of A in Figure 14 for 41405 valves.
- Assemble the two parts of the stem connector (51) and the point (58). The number of threads inside the stem connection must be approximately equal for each stem. Tighten screw(s) (52).
- Check that the travel of the actuator stem corresponds to the normal travel of the valve and that the closed position is obtained for the maximum spring range indicated on the serial plate.
- Shut off the air pressure. Use the pointer (58) to set the travel scale (56). The pointer (58) must indicate "open" when the air pressure is off.

7.6 Coupling of Air-to-Retract Actuator (Type 38)

(Figure 16)

- Connect a temporary air supply line to the actuator. Apply sufficient pressure to the diaphragm to retract the actuator stem completely. Attach the actuator to the valve bonnet with the yoke nut (33) or attachment screws.
- Shut off the air pressure completely. Increase the air pressure to retract the actuator stem by the value of a in Figure 13.

CAUTION

For 41405 valves, use value a1 of Figure 14.

- Assemble the two stem connectors (51) and the pointer (58). The number of threads inside the stem connection must be approximately equal for each stem. Tighten screw(s) (52).
- Check that the travel of the actuator stem corresponds to the effective travel of the valve and that the closed position is obtained for the minimum spring range indicated on the serial plate.
- Shut off the air pressure then use the pointer (58) to set the travel scale (56). The pointer (58) must indicate "closed" when the air pressure is nil.

7.7 Other Types of Pneumatic Actuators

For other type of actuators which the coupling valve actuator is realized by coupling parts (see Figure 16) follow the procedure:

- § 7.5. for actuator opens by air failure.
- § 7.6. for actuator closes by air failure.

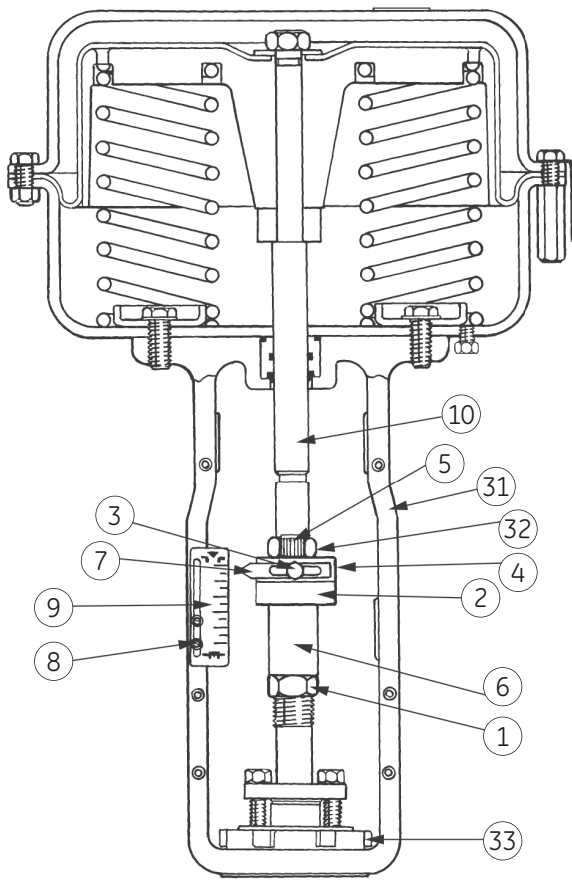

Model 87
No. 10-16-23

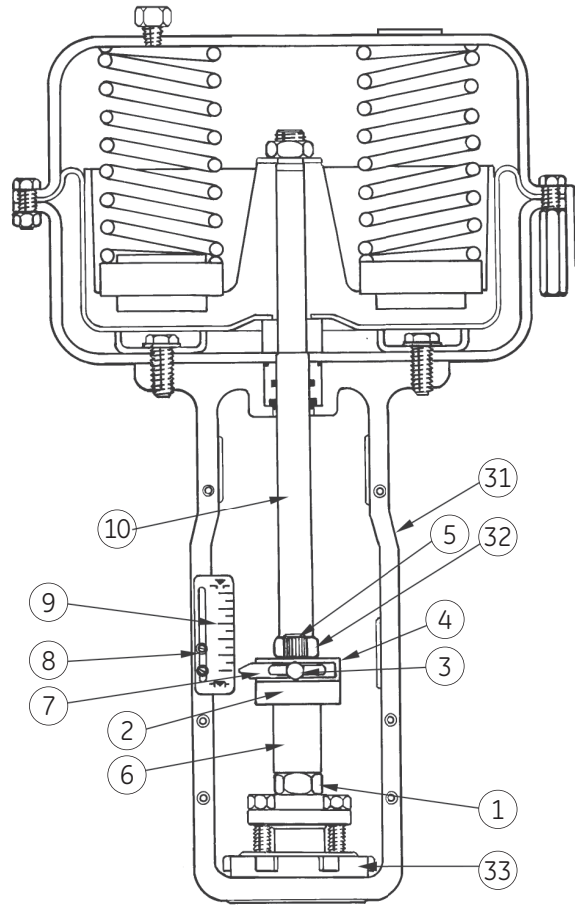

Model 88
No. 10-16-23

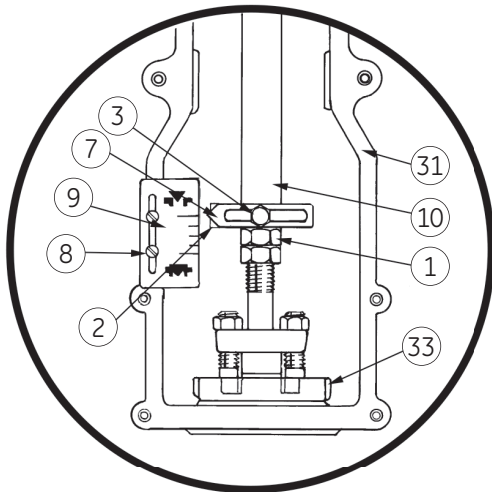

Detail of 87/88 Model
No. 6

Parts Reference	
Ref.	Designation
1	Hex nut
2	Bottom stem connector
3	Pointer screw
★ 4	Top stem connector
★ 5	Cap screw, soc. head
★ 6	Connector Insert
7	Pointer
8	Screw, Pan head (travel scale)
9	Travel scale
10	Actuator stem
31	Yoke
★ 32	Lock nut
33	Drive nut

★ Not provided for size 6 actuator

Figure 15. Spring diaphragm actuators – types 87/88 multispring

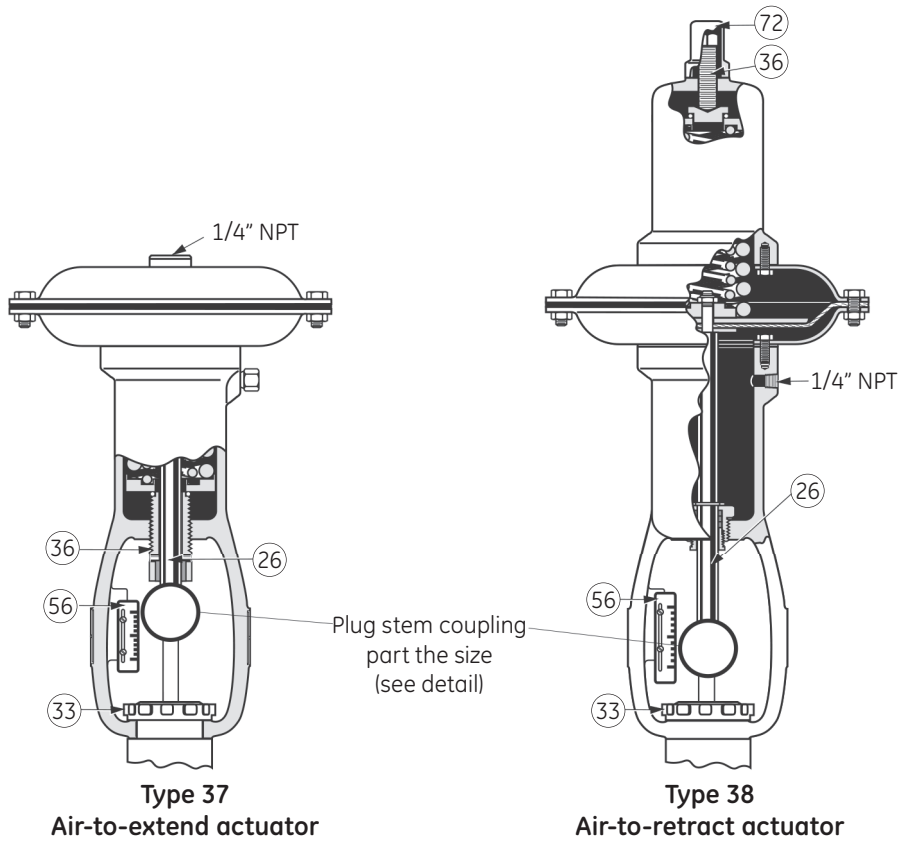

Parts Reference	
Ref.	Designation
1	Valve Plug Stem
26	Actuator stem
27	Stem nut
33	Drive nut
36	Spring adjustor
51	Coupling
52	Coupling screw
53	Coupling nut
55	Frein de tige
56	Travel indicator scale
57	Machine screw
58	Travel indicator
72	Spring barrel cap

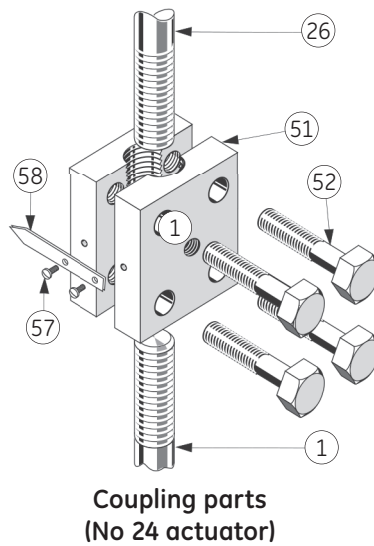
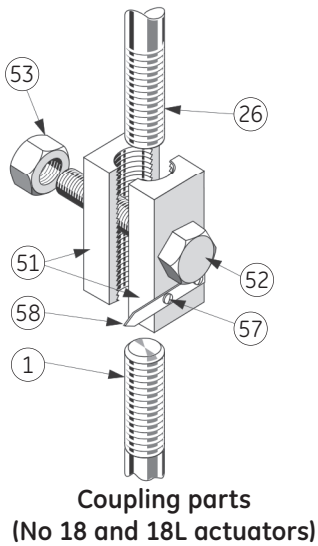

Detail of coupling types of plug stem

Figure 16. Spring diaphragm actuator 37/38 types

Body Sub Assembly

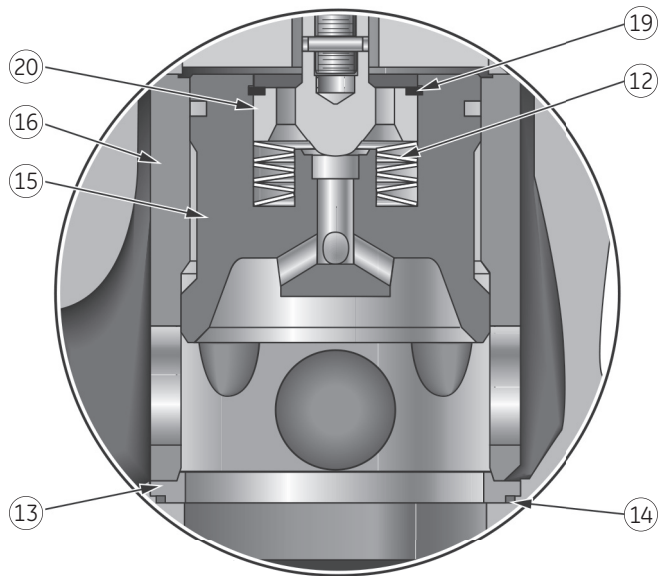

41405 TRIM: 2" to 4"

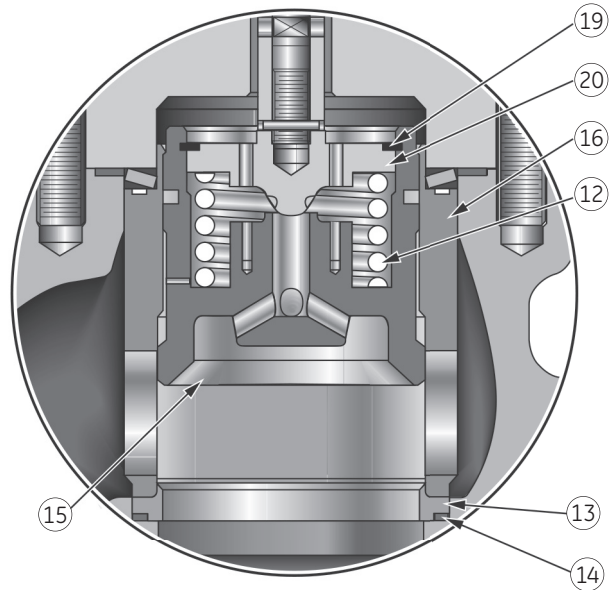

41405 TRIM: 6" to 18"

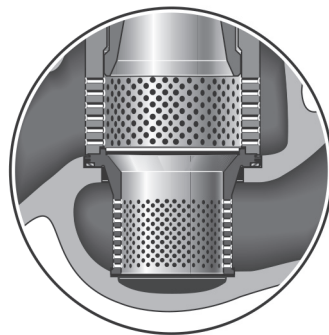

Diffuser Option

Figure 17. Internal parts of pilot plug valve – 41405 type

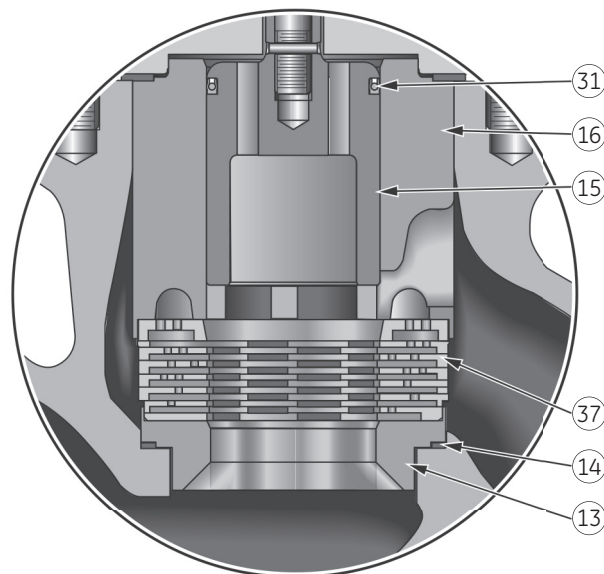
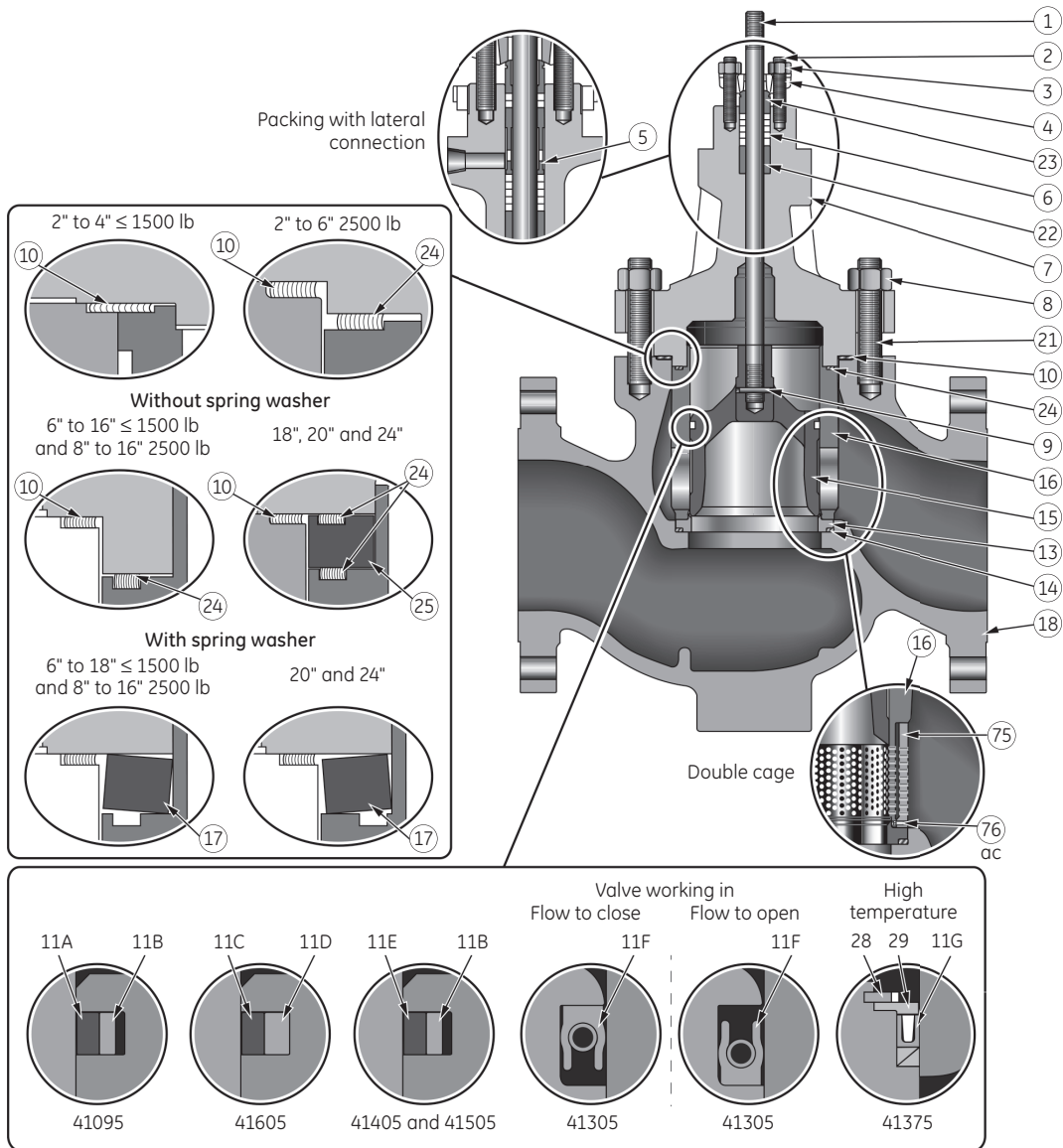

Figure 18. Internal parts of VRT anticavitation valves – 41375 type



Parts Reference					
Ref.	Designation	Ref.	Designation	Ref.	Designation
1	Valve plug stem	★ ● 11D	Elastomer seal ring	21	Valve body stud
2	Packing flange stud	■ ● 11E	Metallic seal ring	22	Guide bushing
3	Packing flange nut	▲ ● 11F	Tec seal	23	Packing follower
4	Packing flange	○ 11G	Seal ring and backup ring	24	Cage gasket
5	Packing spacer	❖ 12	Spring (or spring washers set)	25	Cage washer
● 6	Packing	13	Seat/diffuser seat	○ 28	Retaining ring
7	Bonnet	● 14	Seat ring gasket	○ 29	Retainer ring
8	Valve body nut	15	Valve plug	37	Stack
● 9	Plug stem pin	16	Cage	50	Washer (body nuts)
● 10	Body gasket	◆ 17	Spring washer	75	Double cage
□ ● 11A	Graphite seal ring	18	Valve body	76	Pin
□ ● 11B	Metallic ring	❖ 19	Retaining ring		
★ ● 11C	U PTFE seal ring	❖ 20	Auxiliary pilot plug		
❖	On 41405 series valves only	●	Recommended spare part	▲	On 41305 series valves only
◆	On 6" to 24" valves sizes only (150 to 600 mm)	□	On 41905 series valves only	○	On 41375 high temperature valves only
★	On 41605 series valves only	■	On 41405/505 Series valves only		

DIRECT SALES OFFICE LOCATIONS

AUSTRALIA

Brisbane
Phone: +61-7-3001-4319
Fax: +61-7-3001-4399

Perth
Phone: +61-8-6595-7018
Fax: +61-8-6595-7299

Melbourne
Phone: +61-3-8807-6002
Fax: +61-3-8807-6577

BELGIUM
Phone: +32-2-344-0970
Fax: +32-2-344-1123

BRAZIL
Phone: +55-11-2146-3600
Fax: +55-11-2146-3610

CHINA
Phone: +86-10-5689-3600
Fax: +86-10-5689-3800

FRANCE
Courbevoie
Phone: +33-1-4904-9000
Fax: +33-1-4904-9010

GERMANY
Ratingen
Phone: +49-2102-108-0
Fax: +49-2102-108-111

INDIA
Mumbai
Phone: +91-22-8354790
Fax: +91-22-8354791

New Delhi
Phone: +91-11-2-6164175
Fax: +91-11-5-1659635

ITALY

Phone: +39-081-7892-111
Fax: +39-081-7892-208

JAPAN

Chiba
Phone: +81-43-297-9222
Fax: +81-43-299-1115

KOREA

Phone: +82-2-2274-0748
Fax: +82-2-2274-0794

MALAYSIA

Phone: +60-3-2161-0322
Fax: +60-3-2163-6312

MEXICO

Phone: +52-55-3640-5060

THE NETHERLANDS

Phone: +0031-15-3808666
Fax: +0031-18-1641438

RUSSIA

Veliky Novgorod
Phone: +7-8162-55-7898
Fax: +7-8162-55-7921

Moscow

Phone: +7 495-585-1276
Fax: +7 495-585-1279

SAUDI ARABIA

Phone: +966-3-341-0278
Fax: +966-3-341-7624

SINGAPORE

Phone: +65-6861-6100
Fax: +65-6861-7172

SOUTH AFRICA

Phone: +27-11-452-1550
Fax: +27-11-452-6542

SOUTH & CENTRAL AMERICA AND THE CARIBBEAN

Phone: +55-12-2134-1201
Fax: +55-12-2134-1238

SPAIN

Phone: +34-93-652-6430
Fax: +34-93-652-6444

UNITED ARAB EMIRATES

Phone: +971-4-8991-777
Fax: +971-4-8991-778

UNITED KINGDOM

Bracknell
Phone: +44-1344-460-500
Fax: +44-1344-460-537

Skelmersdale

Phone: +44-1695-526-00
Fax: +44-1695-526-01

UNITED STATES

Massachusetts
Phone: +1-508-586-4600
Fax: +1-508-427-8971

Corpus Christi, Texas

Phone: +1-361-881-8182
Fax: +1-361-881-8246

Deer Park, Texas

Phone: +1-281-884-1000
Fax: +1-281-884-1010

Houston, Texas

Phone: +1-281-671-1640
Fax: +1-281-671-1735



* Denotes a trademark of General Electric Company.

Other company names and product names used in this document are the registered trademarks or trademarks of their respective owners.

© 2015 General Electric Company. All rights reserved.

GEA19369C 07/2015