

Masoneilan* 41005 Series

Complete Line of Rugged,
Cage-Guided, Globe Valves
with Lo-dB* & Anti-Cavitation
Capabilities

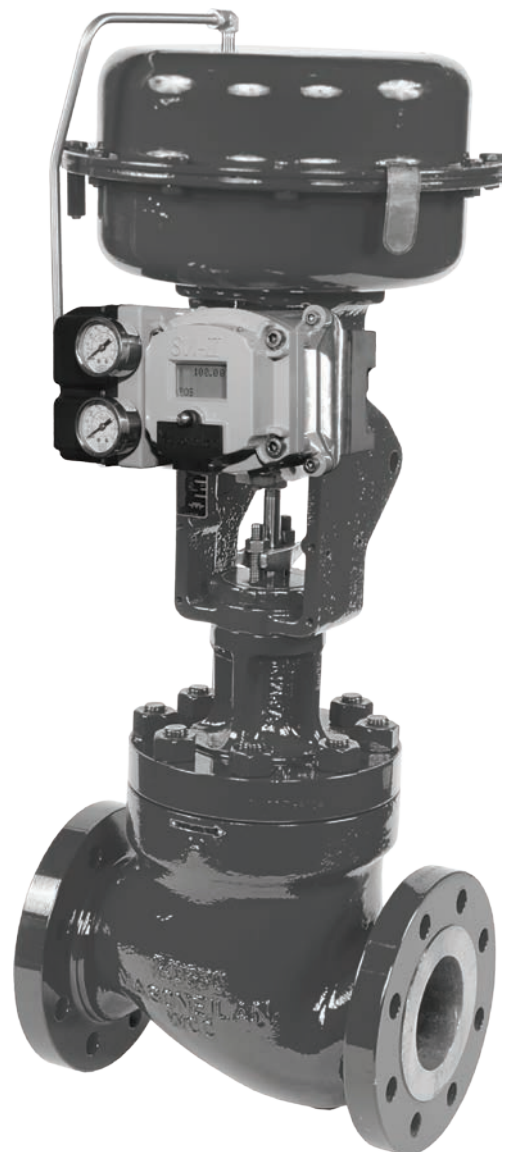
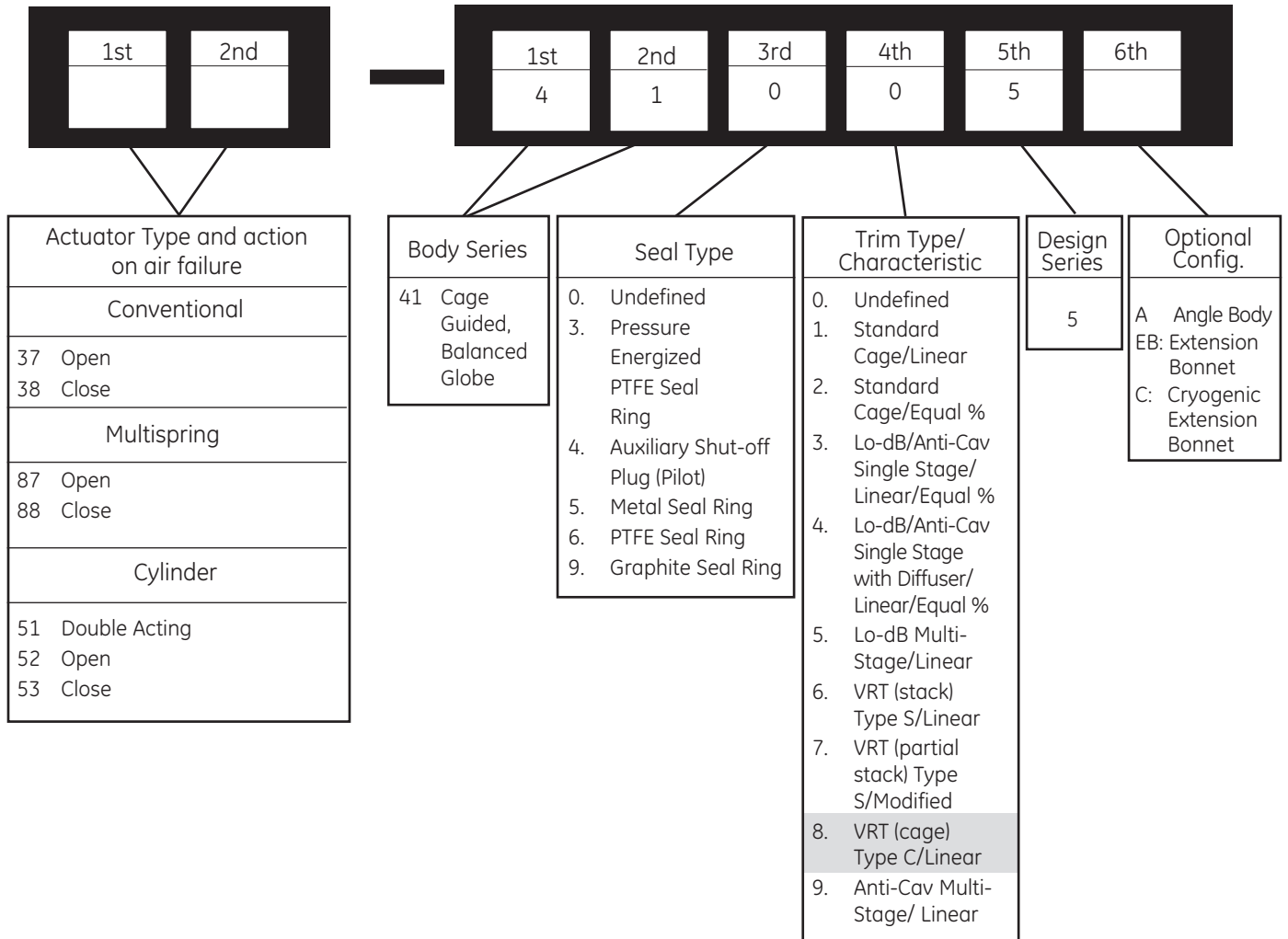

Table of Contents

Numbering System	3	Seal Ring Construction.....	20
Ratings / Connections	4	Materials of Construction	21-24
Seal Type versus Temperature Range /Seat Leakage.....	5	Dimensions (inches)	25-26
Flow Direction	5	Dimensions (mm).....	27-28
C_V and F_L versus Travel.....	6-12	Weights	29-30
Body S/A Construction	13-14	Options	30
Materials of Construction	15-18		
Trim Types.....	19		

Numbering System



Engineered trim options are also available for high temperature and high pressure drop applications. Please consult factory for details.

Ratings / Connections

○ Threaded

● Socket Weld

■ Butt Weld

□ RF & RTJ

Valve Size		ANSI Class 150 to 1500 and equivalent PN		ANSI Class 2500 and equivalent PN
inch	mm	■	●	□
2	50	■	●	□
3 to 16	80 to 400	■	●	□
3x2	80x50	■	●	□
4x2	100x50	■	●	□
4x3	100x80	■	●	□
6x3	150x80	■	●	□
6x4	150x100	■	●	□
8x4	200x100	■	●	□
8x6	200x150	■	●	□
10x6	250x150	■	●	□
10x8	250x200	■	●	□
12x8	300x200	■	●	□
16x12	400x300	■	●	□
18 ⁽¹⁾	450	■	●	□
20 ⁽¹⁾	500	■	●	□
24 ⁽¹⁾	600	■	●	□

Notes: 1. 16" and 18" (400 & 500 mm) sizes are limited to ANSI 1500 Class. 20" (500 mm) is limited to ANSI 900 Class. 24" (600mm) size is limited to ANSI 600 Class.

Angle Body Version is available in valve sizes 2" - 6" with ANSI ratings from Class 150 to Class 1500 and standard raised face end connections.

Ex. 3x2 size = valve with 3" body x standard 2" trim.

Consult GE for AFNOR and DIN connections.

■ = ANSI Class 2500 Ratings are available. Please consult factory for details.

Seal Type versus Temperature Range / Seat Leakage

Valve Model	Seal Type	Valve Size		Temperature Range ⁽¹⁾		Seat Leakage per IEC 534-4 and ANSI / FCI 70.2 Class
		inches	mm	Minimum	Maximum	
41305	Pressure Energized PTFE Seal Ring	2 - 24	50 - 600	-148°F (-100°C)	+450°F (+232°C)	IV (standard) V (optional)
		2 - 12 ⁽³⁾	50 - 300		+575°F (+302°C)	
41405 ⁽²⁾	Auxiliary Pilot Plug with Metal Seal Ring	2	50	-320°F (-196°C)	+1050°F (+566°C)	IV (standard) V (optional)
		3 - 4	80 - 100	-320°F (-196°C)	+800°F (+427°C)	
		6 - 18	150 - 450	-320°F (-196°C)	+1050°F (+566°C)	
41505	Metal Seal Ring	2	50	-320°F (-196°C)	+1050°F (+566°C)	II
		3 - 4	80 - 100	-320°F (-196°C)	+800°F (+427°C)	II
		6 - 18	150 - 450	-320°F (-196°C)	+1050°F (+566°C)	III
		20 & 24	500 & 600	-51°F (-46°C)	+650°F (+343°C)	III
41605	PTFE Seal Ring	2 - 24	50 - 600	-20°F (-29°C)	+300°F (+149°C)	IV
41905	Graphite Seal Ring	2	50	-320°F (-196°C)	+1050°F (+566°C)	III
		3 - 4	80 - 100	-320°F (-196°C)	+800°F (+427°C)	III
		6 - 18	150 - 450	-320°F (-196°C)	+850°F (+454°C)	IV
		20 & 24	500 & 600	-51°F (-46°C)	+650°F (+343°C)	IV

Notes: 1. See Materials of Construction Tables for other temperature limitations.
 2. Not available in 20" or 24" sizes.
 3. Pressure Energized PTFE Seal w/ backup rings for 2-12" up to 575°F (302°C)

Flow Direction

Model Number	41305	41405 ^{(1) (4)}	41505	41605	41905
Seal Type	Pressure Energized PTFE Seal Ring	Auxiliary Pilot Plug with Metal Seal Ring	Metal Seal Ring	PTFE Seal Ring	Graphite Seal Ring
Standard Trim 41015/41025	41315/41325 FTO or FTC ⁽²⁾	41415/41425 FTC	41515/41525 FTO or FTC	41615/41625 FTO or FTC	41915/41925 FTO or FTC
Lo-dB Single Stage 41035	41335 FTO	41435 FTC	41535 FTO	41635 FTO	41935 FTO
Anti-Cavitation Single Stage 41035	41335 FTC	41435 FTC	41535 FTC	41635 FTC	41935 FTC
Lo-dB & Anti-Cavitation Single Stage with Internal Diffuser ⁽³⁾ 41045	41345 FTC	41445 FTC	41545 FTC	41645 FTC	41945 FTC
Lo-dB Multi-Stage 41055	41355 FTO	N/A	41555 FTO	41655 FTO	41955 FTO
High Pressure Anti-Cavitation VRT	41365 ⁽⁵⁾ 41375 ⁽⁶⁾	N/A	N/A	N/A	N/A
Anti-Cavitation Multi-Stage 41095	41395 FTC	N/A	41595 FTC	41695 FTC	41995 FTC

Notes: 1. Flow direction for Pilot Plug Seal configuration is always FTC.
 2. Seal ring must be installed in correct orientation relative to high pressure direction.
 3. Flow direction with Internal Diffuser is always FTC.
 4. 41405 is not available in 20" or 24" sizes.
 5. 41365 available in 8", 10" and 12" sizes.
 6. 41375 available in 3" to 10".

C_v and F_L versus Travel

Standard Trim

Models: 41315, 41415⁽¹⁾, 41515, 41615 and 41915

Flow Characteristic: LINEAR

Percent of Travel							10	20	30	40	50	60	70	80	90	100	
F _L							0.94	0.94	0.93	0.93	0.92	0.92	0.91	0.91	0.90	0.90	0.90
Valve Size		ASME CLASS and equivalent PN	Orifice Diameter		Travel		Rated C _v										
inches	mm		in.	mm	in.	mm											
2	50	900-1500-2500	1.84	46.7	0.8	20.3	1.4	2.7	4.2	6	8	10	12.5	14	15.5	16	
							2	4.9	8.3	13	19	25	30	35	38	40	
2	50	150-600	2.5	63.5	1.5	38.1	2.7	5.1	7.9	11	15	19	23	26	29	30	
3x2 ⁽²⁾ 4x2	80x50 100x50	150-1500					4	9	15	24	35	47	57	65	71	75	
3	80	2500					5	10	16	22	30	38	46	52	58	60	
3 4x3 6x3	80 100x80 150x80	150-1500	3.5	88.9	2	50.8	8	19	31	50	73	96	118	135	147	155	
4	100	2500					9	16	25	35	48	60	72	83	91	95	
4 6x4 8x4	100 150x100 200x100	150-1500	4.38	111.3	2	50.8	12	29	48	77	113	149	182	209	228	240	
6	150	2500					7	15	28	41	58	74	94	117	144	165	
6 8x6 10x6	150 200x150 250x150	150-1500	5.12	130.0	0.8 ⁽³⁾	20.3 ⁽³⁾	20	52	92	148	204	260	308	348	376	400	
8	200	2500			2	50.8	17	37	71	104	145	187	237	295	361	415	
8 10x8 12x8	200 250x200 300x200	150-1500	6.5	165.1	1.5	38.1	32	83	147	237	326	416	493	557	602	640	
10	250	2500			2.5	36.5	20	46	87	128	179	230	291	362	444	510	
10	250	150-1500	8	203.2	1.5	38.1	50	130	230	370	510	650	770	870	940	1000	
12	300	2500			3	76.2	31	69	131	193	270	347	439	547	670	770	
12 16x12	400 400x300	150-1500	9.75	247.65	2	50.8	70	182	322	518	714	910	1078	1218	1316	1400	
16	400	2500			3.75	95.3	51	128	211	320	448	576	730	922	1114	1280	
16	400	150-1500	13	330.2	2.5	63.5	104	268	464	744	1024	1304	1544	1720	1880	2000	
					4	101.6	130	335	580	930	1280	1630	1930	2150	2350	2500	
					5	127.0	84	217	376	603	829	1056	1251	1393	1523	1620	
18	450	150-1500	14.5	368.3	3.5	88.9	120	310	536	859	1183	1506	1783	1987	2171	2310	
					5	127.0	168	434	752	1205	1659	2112	2501	2786	3046	3240	
					7	177.8	79	422	790	1158	1517	1860	2182	2481	2753	3000	
20	500	150-900	19	482.6	4	101.6	244	792	1343	1866	2342	2762	3124	3431	3688	3900	
					6	152.4	524	1356	2103	2724	3219	3604	3907	4147	4342	4500	
					9	228.6	114	608	1138	1668	2187	2688	3161	3604	4011	4300	
24	600	150-600	23	330.2	4	101.6	345	1115	1892	2635	3321	3933	4468	4928	5320	5600	
					6	152.4	703	1832	2871	3765	4499	5094	5569	5952	6265	6500	
					9	228.6	964	2327	3511	4460	5191	5749	6180	6519	6793	7000	
					11	279.4	114	608	1138	1668	2187	2688	3161	3604	4011	4300	

Notes: 1. Model 41415 is not available in 20" and 24" sizes.
 2. Ex. 3x2 size = valve with 3" body with standard 2" trim.
 3. Travel of 1.5 inches (38.1 mm) for 41405.

C_v and F_L versus Travel

Standard Trim

Models: 41325, 41425⁽¹⁾, 41525, 41625 and 41925

Flow Characteristic: EQUAL PERCENTAGE

Percent of Travel							10	20	30	40	50	60	70	80	90	100	
F _L							0.94	0.94	0.94	0.94	0.94	0.94	0.93	0.92	0.92	0.92	0.90
Valve Size		ASME CLASS and equivalent PN	Orifice Diameter		Travel		Rated C _v										
in.	mm		in.	mm	in.	mm											
2	50	900-1500-2500	1.84	46.7	0.8	20.3	0.2	0.4	0.8	1.3	2.1	3.8	6.7	10	12	14	
							0.5	1.1	2	3.2	5.2	9.5	17	25	31	35	
2 3x2 ⁽²⁾ 4x2	50 80x50 100x50	150-600	2.5	63.5	1.5	38.1	0.3	0.8	1.5	2.3	4	7	12	18	23	26	
3	80	2500					0.8	2	4	6	10	18	31	46	58	65	
3 4x3 6x3	80 100x80 150x80	150-1500	3.5	88.9	2	50.8	0.7	1.7	3	5	8	15	27	39	50	56	
4	100	2500					1.8	4	8	13	21	38	67	100	124	140	
4 6x4 8x4	100 150x100 200x100	150-1500	4.38	111.3	2	50.8	1.2	3	5	8	13	24	43	64	81	90	
6	150	2500					3	7	13	20	33	61	107	160	200	225	
6 8x6 10x6	150 200x150 250x150	150-1500	5.12	130.0	2	50.8	4	8	15	24	35	54	80	108	130	144	
8	200	2500					9	21	39	60	87	135	200	269	326	360	
8 10x8 12x8	200 250x200 300x200	150-1500	6.5	165.1	2.5	63.5	6	14	25	39	56	86	128	172	208	230	
10	250	2500					14	34	62	97	140	215	320	430	521	575	
10	250	150-1500	8	203.2	3	76.2	9	21	39	60	87	135	200	269	326	360	
12	300	2500					23	53	97	151	219	337	500	672	815	900	
12 16x12	400 400x300	150-1500	9.75	247.65	3.75	95.3	13	30	54	84	122	187	278	374	453	500	
16	400	2500					32	75	136	212	306	471	700	941	1142	1260	
16	400	150-1500	13	330.2	5	127.0	22	53	97	151	219	337	500	672	815	900	
							56	133	243	378	547	842	1251	1681	2038	2250	
18	450	150-1500	14.5	368.3	5	127.0	29	69	125	195	282	434	645	867	1051	1160	
					7	177.8	72	171	313	487	705	1085	1612	2167	2627	2900	
20	500	150-900	19	482.6	4	101.6	12	82	162	257	386	589	854	1119	1375	1620	
					9	228.6	75	218	404	656	981	1426	2109	2944	3596	4050	
24	600	150-600	23	330.2	6	152.4	39	139	249	386	574	852	1256	1694	2118	2520	
					11	279.4	133	344	572	1005	1608	2406	3553	4814	5692	6300	

Notes: 1. Model 41425 is not available in 20" and 24" sizes.
 2. Ex. 3x2 size = valve with 3" body with standard 2" trim.

C_v and F_L versus Travel

Single Stage Lo-dB/Anti-Cavitation

Models: 41335, 41435⁽¹⁾, 41535, 41635, 41935, 41X45 (with internal diffuser)

Flow Characteristic: LINEAR

Percent of Travel							10	20	30	40	50	60	70	80	90	100		
F _L							0.94	0.94	0.94	0.94	0.94	0.94	0.94	0.94	0.94	0.94	0.94	
Valve Size		ASME CLASS and equivalent PN	Orifice Diameter		Travel		Rated C _v											
in.	mm		in.	mm	in.	mm	1	2	3	4	5	6	7	8	9	10		
2	50	900-2500	1.84	46.7	0.8	20.3	1	2	3	4	5	6	7	8	9	10		
							1.3	2.6	3.9	5.2	6.5	7.8	9.1	10.4	11.7	13		
							1.7	3.4	5.1	6.8	8.5	10.2	11.9	13.6	15.3	17		
							2.3	4.6	6.9	9.2	11.5	13.8	16.1	18.4	20.7	23		
2	50	150-600	2.5	63.5	1.5	38.1	2.5	5	7.5	10	12.5	15	17.5	20	22.5	25		
							3	6	10	13	16	19	22	26	29	32		
							4	9	13	17	22	26	30	34	39	43		
							6	12	17	23	29	35	41	46	52	58		
3x2 4x2	80x50 100x50	150-1500	3.5	88.9	2	50.8	7	14	22	29	36	43	50	58	65	72		
							4	8	12	16	20	24	28	32	36	40		
							5	11	16	22	27	32	38	43	49	54		
							7	14	22	29	36	43	50	58	65	72		
3 4x3 6x3	80 100x80 150x80	150-1500	4.38	111.3	2	50.8	10	19	29	38	48	57	67	76	86	95		
							13	25	38	50	63	75	88	100	113	125		
							7	13	20	26	33	39	46	52	59	65		
							9	17	26	34	43	51	60	68	77	85		
4 6x4 8x4	100 150x100 200x100	150-1500	5.12	130.0	2.5	63.5	11	22	33	44	55	66	77	88	99	110		
							15	30	45	60	75	90	105	120	135	150		
							20	39	59	78	98	117	137	156	176	195		
							10	20	30	40	50	60	70	80	90	100		
6 8x6 10x6	150 200x150 250x150	150-1500	6.5	165.1	2.5	63.5	13	26	39	52	65	78	91	104	117	130		
							18	35	53	70	88	105	123	140	158	175		
							23	46	69	92	115	138	161	184	207	230		
							30	60	90	120	150	180	210	240	270	300		
8 10x8 12x8	200 250x200 300x200	150-1500	8	203.2	2.5	63.5	16	32	48	64	80	96	112	128	144	160		
							21	42	63	84	105	126	147	168	189	210		
							27	54	81	108	135	162	189	216	243	270		
							36	72	108	144	180	216	252	288	324	360		
10	250	2500	9.75	247.7	3	76.2	50	100	150	200	250	300	350	400	450	500		
							20	40	60	80	100	120	140	160	180	200		
							26	52	78	104	130	156	182	208	234	260		
							36	72	108	144	180	216	252	288	324	360		
12	300	2500	13	330.2	3.5	88.9	50	100	150	200	250	300	350	400	450	500		
							65	130	195	260	325	390	455	520	585	650		
							45	90	135	180	225	270	315	360	405	450		
							60	120	180	240	300	360	420	480	540	600		
12 16x12	400 400x300	150-1500	14.5	368.3	4	101.6	81	162	243	324	405	486	567	648	729	810		
							5	127	110	220	330	440	550	660	770	880	990	1100
							2.5	63.5	73	146	219	292	365	438	511	584	657	730
							99	198	297	396	495	594	693	792	891	990		
16	400	150-1500	19	482.6	6	152.4	130	260	390	520	650	780	910	1040	1170	1300		
							180	360	540	720	900	1080	1260	1440	1620	1800		
							3.5	88.9	107	214	321	428	535	642	749	856	963	1070
							139	278	417	556	695	834	973	1112	1251	1390		
18	450	150-1500	23	584.2	7	177.8	185	370	555	740	925	1110	1295	1480	1665	1850		
							243	486	729	972	1215	1458	1701	1944	2187	2430		
							4	101.6	190	380	570	760	950	1140	1330	1520	1710	1900
							6	152.4	280	560	840	1120	1400	1680	1960	2240	2520	2800
20	500	150-900	4	101.6	270	540	810	1080	1350	1620	1890	2160	2430	2700				
							6	152.4	350	700	1050	1400	1750	2100	2450	2800	3150	3500
							9	228.6	350	700	1050	1400	1750	2100	2450	2800	3150	3500
							6	152.4	350	700	1050	1400	1750	2100	2450	2800	3150	3500
24	600	150-600	9	228.6	480	960	1440	1920	2400	2880	3360	3840	4320	4800				
							11	279.4	540	1080	1620	2160	2700	3240	3780	4320	4860	5400
							15	381	660	1320	1980	2640	3300	3960	4620	5280	5940	6600

Notes: 1. Model 41435 is not available in 20" and 24" sizes.

Internal diffuser design only available for valve sizes 6" to 16" (150 to 400mm) and with capacities shaded above..

C_v and F_L versus Travel

Single-Stage Lo-dB/Anti-Cavitation
Models: 41335, 41435, 41535, 41635 and 41935

Flow Characteristic: EQUAL PERCENTAGE

Percent of Travel							10	20	30	40	50	60	70	80	90	100	
F _L							0.94	0.94	0.94	0.94	0.94	0.94	0.94	0.94	0.94	0.94	0.94
Valve Size		ASME CLASS and equivalent PN	Office Diameter		Travel		Rated C _v										
in.	mm		in.	mm	in.	mm											
2	50	900-2500	1.84	46.7	0.8	20.3	0.2	0.3	0.6	1	1.6	3	5.2	7.9	9.8	11	
							0.2	0.5	0.9	1.5	2.4	4.4	7.6	11.4	14.2	16	
							0.3	0.7	1.3	2.1	3.4	6.3	11	16.5	20.4	23	
2	50	150-600	2.5	63.5	1.5	38.1	0.3	0.8	1.5	2.4	3.8	7.1	12.4	18.5	23.1	26	
3x2 ⁽¹⁾	80x50	150-1500					0.5	1.2	2.2	3.5	5.6	10.4	18.1	27.1	33.8	38	
4x2	100x50	2500					0.7	1.7	3.1	4.9	8	14.8	25.8	38.5	48	54	
3	80	2500	3.5	88.9	2	50.8	0.6	1.3	2.7	4.4	7.1	12.8	22.5	33.6	41.6	47	
3	80	150-1500					0.9	1.9	3.8	6.2	10.1	18.2	32.1	47.9	59.4	67	
4x3	100x80	2500					1.2	2.7	5.5	8.9	14.4	26.1	46	68.6	85.1	96	
4	100	2500	4.38	111.3	2	50.8	0.9	2.2	4	6.2	10.3	19	33.3	49.8	62.2	70	
4	100	150-1500					1.3	3.1	5.8	8.9	14.7	27.2	47.6	71.2	88.9	100	
6x4	150x100	2500					1.9	4.5	8.4	12.9	21.3	39.4	69.1	103.2	128.9	145	
6	150	2500	5.12	130.0	2.5	63.5	3	6	12	18	27	41	61	82	99	110	
6	150	150-1500					3.9	9.1	16.9	25.9	37.6	58.3	86.4	116	140.5	155	
8x6	200x150	2500					5.7	13.2	24.5	37.7	54.7	84.8	125.4	168.3	203.8	225	
8	200	2500	6.5	165.1	3	76.2	4	11	19	30	44	67	100	135	163	180	
8	200	150-1500					6	15	28	44	64	97	145	195	236	260	
10x8	250x200	2500					9	22	41	64	92	141	209	281	340	375	
10	250	2500	8	203.2	3.5	88.9	6	14	25	39	56	86	128	172	208	230	
10	250	150-1500					9	20	37	57	83	128	190	254	308	340	
12	300	2500					12	29	53	82	119	183	270	363	439	485	
12	400	150-1500	9.75	247.7	5	127	10	24	43	67	97	150	222	299	363	400	
16x12	400x300	2500					15	34	62	97	140	215	320	430	521	575	
16	400	2500					21	49	89	139	201	309	459	617	748	825	
16	400	150-1500	13	330.2	6	152.4	17	39	72	112	162	249	370	497	603	665	
							24	56	103	160	232	356	529	711	861	950	
							34	80	146	228	329	507	752	1009	1223	1350	

Note: 1. Ex. 3x2 size = valve with 3" body with standard 2" trim.

C_v and F_L versus Travel

Multi-Stage Lo-dB

Models: 41355, 41555, 41655 and 41955

Flow Characteristic: LINEAR

Percent of Travel							10	20	30	40	50	60	70	80	90	100		
F _L							0.95	0.95	0.95	0.95	0.95	0.95	0.95	0.95	0.95	0.95	0.95	
Valve Size		ASME CLASS and equivalent PN	Orifice Diameter		Travel		Rated C _v											
in.	mm		in.	mm	in.	mm												
2	50	900-2500	1.84	46.7	0.8	20.3	1.2	2.4	3.6	4.8	6	7.2	8.4	9.6	10.8	12		
							1.9	3.8	5.7	7.6	9.5	11.4	13.3	15.2	17.1	19		
							2.4	4.8	7.2	9.6	12	14.4	16.8	19.2	21.6	24		
2	50	150-600	2.5	63.5	1.5	38.1	3	6	9	12	15	18	21	24	27	30		
3x2 ⁽¹⁾	80x50	150-1500					4	9	13	17	22	26	30	34	39	43		
4x2	100x50						5	11	16	21	27	32	37	42	48	53		
3	80	2500	3.5	88.9	2	50.8	5	10	15	20	25	30	35	40	45	50		
3	80	150-1500					8	15	23	30	38	45	53	60	68	75		
4x3	100x80						10	19	29	38	48	57	67	76	86	95		
6x3	150x80	2500	4.38	111.3	2	50.8	7	14	22	29	36	43	50	58	65	72		
4	100	150-1500					11	21	32	42	53	63	74	84	95	105		
4	100						13	26	39	52	65	78	91	104	117	130		
6x4	150x100	150-1500	5.12	130.0	2.5	63.5	10	19	29	38	48	58	67	77	86	96		
8x4	200x100						15	30	45	60	75	90	105	120	135	150		
6	150	2500					19	38	57	76	95	114	133	152	171	190		
8	200	2500	6.5	165.1	2.5	63.5	16	31	47	62	78	93	109	124	140	155		
8	200	150-1500					25	50	75	100	125	150	175	200	225	250		
10x8	250x200						3	76.2	30	60	90	120	150	180	210	240	270	
12x8	300x200	2500	8	203.2	2.5	63.5	23	46	69	92	115	138	161	184	207	230		
10	250	150-1500					35	70	105	140	175	210	245	280	315	350		
10	250						3	76.2	42	84	126	168	210	252	294	336	378	
12	300	2500	9.75	247.7	2.5	63.5	38	75	113	150	188	225	263	300	338	375		
12	400	150-1500					4	101.6	60	120	180	240	300	360	420	480	540	600
16x12	400x300						5	127	73	145	218	290	363	435	508	580	653	725
16	400	2500	13	330.2	2.5	63.5	50	100	150	200	250	300	350	400	450	500		
16	400	150-1500					4	101.6	80	160	240	320	400	480	560	640	720	800
							6	152.4	111	221	332	442	553	663	774	884	995	1105
18	450	150-1500	14.5	368.3	3.5	88.9	73	146	219	292	365	438	511	584	657	730		
							5	127	117	234	351	468	585	702	819	936	1053	1170
							7	177.8	146	292	438	584	730	876	1022	1168	1314	1460
20	500	150-900	19	482.6	4	101.6	110	220	330	440	550	660	770	880	990	1100		
							6	152.4	160	320	480	640	800	960	1120	1280	1440	1600
							9	228.6	230	460	690	920	1150	1380	1610	1840	2070	2300
24	600	150-600	23	584.2	4	101.6	130	260	390	520	650	780	910	1040	1170	1300		
							6	152.4	190	380	570	760	950	1140	1330	1520	1710	1900
							9	228.6	280	560	840	1120	1400	1680	1960	2240	2520	2800
							11	279.4	320	640	960	1280	1600	1920	2240	2560	2880	3200
							15	381	420	840	1260	1680	2100	2520	2940	3360	3780	4200

Note: 1. Ex. 3x2 size=valve with 3" body with standard 2" trim

C_v and F_L versus Travel

Multi-Stage Anti-Cavitation
Models: 41395, 41595, 41695 and 41995

Flow Characteristic: LINEAR

Percent of Travel							10	20	30	40	50	60	70	80	90	100		
F _L							0.95	0.95	0.95	0.95	0.95	0.95	0.95	0.95	0.95	0.95	0.95	
Valve Size		ASME CLASS and equivalent PN	Orifice Diameter		Travel		Rated C _v											
in.	mm		in.	mm	in.	mm												
2	50	900-2500	1.521	38.6	0.8	20.3	0.9	1.8	2.7	3.6	4.5	5.4	6.3	7.2	8.1	9		
							1.3	2.6	3.9	5.2	6.5	7.8	9.1	10.4	11.7	13		
							1.5	3	4.5	6	7.5	9	10.5	12	13.5	15		
2 3x2 ⁽¹⁾ 4x2	50 80x50 100x50	150-600	2.151	54.6	1.5	38.1	2.3	4.6	6.9	9.2	12	14	16	18	21	23		
							3.5	7	10.5	14	18	21	25	28	32	35		
3	80	2500					4.4	8.8	13.2	18	22	26	31	35	40	44		
3 4x3 6x3	80 100x80 150x80	150-1500	3.15	80.0	1.5	38.1	4	8	12	16	20	24	28	32	36	40		
							6.5	13	20	26	33	39	46	52	59	65		
4	100	2500					8	16	24	32	40	48	56	64	72	80		
4x3 6x3	100x80 150x80	150-1500	3.15	80.0	2	50.8	9.3	18.6	28	37	47	56	65	74	84	93		
							6.5	13	20	26	33	39	46	52	59	65		
4 6x4 8x4	100 150x100 200x100	150-1500	4.023	102.2	2	50.8	10.5	21	32	42	53	63	74	84	95	105		
							12.5	25	38	50	63	75	88	100	113	125		
6 8x6 10x6	150 200x150 250x150	150-1500	4.777	121.3	2.5	63.5	10	20	30	40	50	60	70	80	90	100		
							16	32	48	64	80	96	112	128	144	160		
8 10x8 12x8	200 250x200 300x200	150-1500	6.146	156.1	2.5	63.5	20	39	59	78	98	117	137	156	176	195		
							17	34	51	68	85	102	119	136	153	170		
10	250	2500	6.146	156.1	3	76.2	26	52	78	104	130	156	182	208	234	260		
							32	64	96	128	160	192	224	256	288	320		
10	250	150-1500	7.63	193.8	2.5	63.5	23	46	69	92	115	138	161	184	207	230		
							38	76	114	152	190	228	266	304	342	380		
12	300	2500					45	90	135	180	225	270	315	360	405	450		
12 16x12	400 400x300	150-1500	9.373	238.1	2.5	63.5	40	80	120	160	200	240	280	320	360	400		
							64	128	192	256	320	384	448	512	576	640		
16	400	2500					5	127	80	160	240	320	400	480	560	640	720	800
16	400	150-1500	13	330.2	2.5	63.5	60	120	180	240	300	360	420	480	540	600		
							4	101.6	95	190	285	380	475	570	665	760	855	950
							6	152.4	131	262	393	524	655	786	917	1048	1179	1310

Note: 1. Ex. 3x2 size=valve with 3" body with standard 2" trim

C_v and F_L versus Travel

Variable Resistance Trim (VRT) Type S
Model: 41365

Flow Characteristic: LINEAR

Percent of Travel								10	20	30	40	50	60	70	80	90	100
F _L								0.999	0.999	0.999	0.998	0.997	0.996	0.994	0.992	0.990	0.988
Valve Size		ASME CLASS and equivalent PN	Orifice Diameter		Travel		Minimum Operable C _v	Rated C _v									
in.	mm		in.	mm	in.	mm											
8	200	300 - 1500	2.99	75.9	4	101.6	2.1	12	24	36	48	60	72	84	96	108	120
10	250	300 - 1500	4.1	104.1	4	101.6	2.3	19	38	57	76	95	114	133	152	171	190
12	300	300 - 1500	4.91	124.7	4	101.6	2.8	27	54	81	108	135	162	189	216	243	270

C_v and F_L versus Travel

Variable Resistance Trim (VRT) Partial Stack Type S
Model: 41375

Flow Characteristic: LINEAR

Percent of Travel								10	20	30	40	50	60	70	80	90	100	
Valve Size		ASME CLASS and equivalent PN	Orifice Diameter		Travel		Minimum Operable C _v	Rated C _v										
in.	mm		in.	mm	in.	mm												
3	80	150-1500	2.42	61.5	2.5	63.5	1.0	Cv	7	11	15	23	33	42	54	67	83	95
4	100	2500						FI	0.998	0.996	0.991	0.98	0.958	0.927	0.92	0.92	0.92	0.92
4	100	150-1500	2.99	75.9	2.5	63.5	1.3	Cv	7	11	17	25	36	52	66	86	113	140
6	150	2500						FI	0.998	0.996	0.991	0.98	0.956	0.927	0.92	0.92	0.92	0.92
6	150	150-1500	3.99	101.3	3.5	88.9	1.8	Cv	14	22	35	57	82	115	163	210	245	270
8	200	2500						FI	0.998	0.995	0.987	0.969	0.929	0.92	0.92	0.92	0.92	0.92
8	200	150-1500	5.36	136.1	4	101.6	3.8	Cv	22	38	58	99	140	192	280	360	425	480
10	250	2500						FI	0.998	0.994	0.984	0.962	0.926	0.92	0.92	0.92	0.92	0.92
10	250	150-1500	7.49	190.2	4	101.6	3.9	Cv	22	43	65	110	165	240	375	520	640	750
12	300	2500						FI	0.998	0.994	0.982	0.956	0.923	0.92	0.92	0.92	0.92	0.92

Note: Throttling at less than minimum operable C_v levels for extended period of time can result in trim damage.

Body S/A Construction

Models 41X15, 41X25, 41X35, 41X45, 41X55, & 41X95

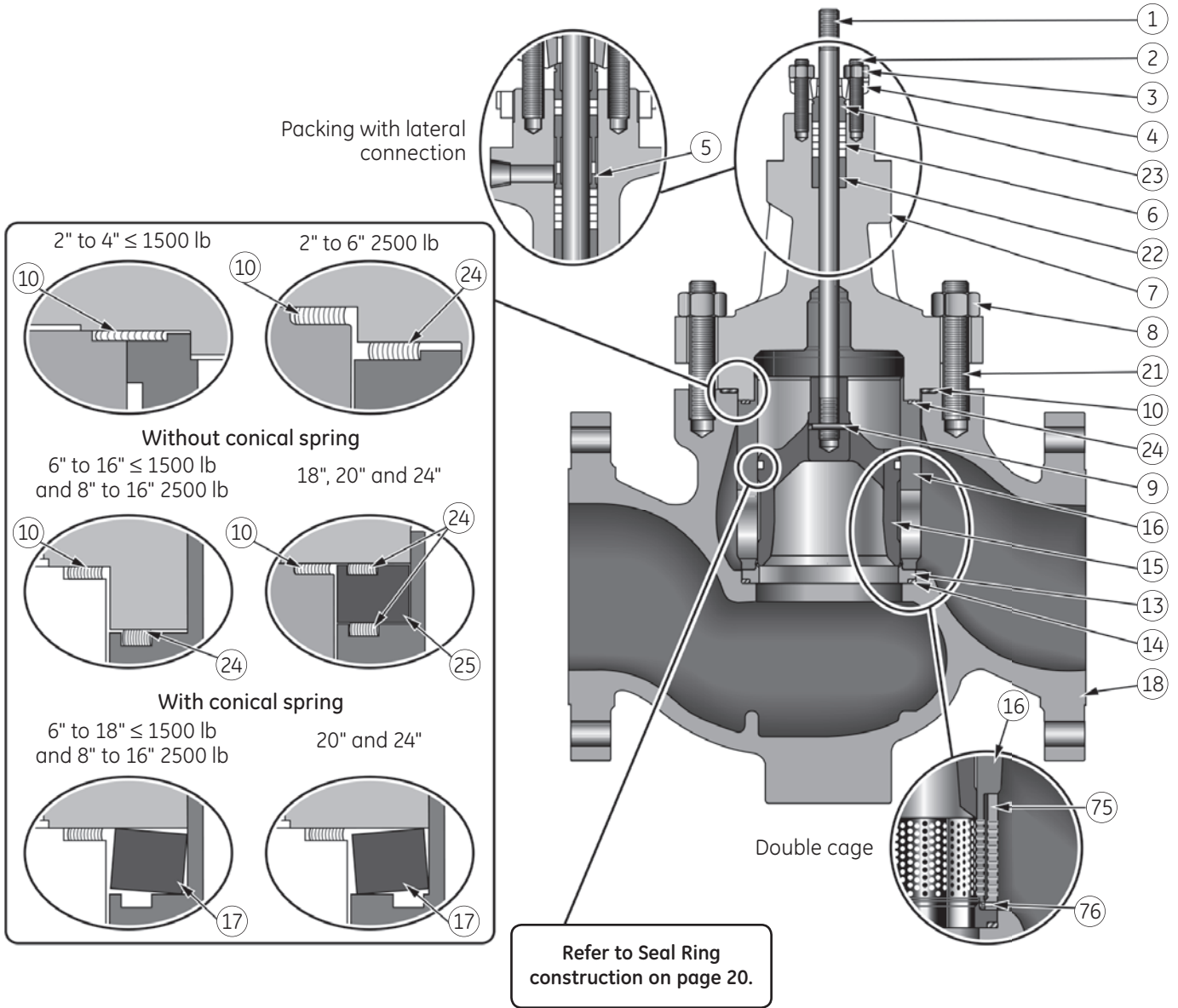

Body S/A Construction

Models 41X15, 41X25, 41X35, 41X45, 41X55, & 41X95

Ref. No.	Part Name
1	Valve Plug Stem
2	Packing Flange Stud
3	Packing Flange Nut
4	Packing Flange
5	Packing Spacer
●	6 Packing
7	Bonnet
8	Valve Body Nut
9	Plug Stem Pin
●	10 Body Gasket
*	12 Pilot Spring(s)
13	Seat Ring
●	14 Seat Ring Gasket
15	Valve Plug (or Piston)
16	Cage
+	17 Conical Spring
18	Valve Body
*	19 Retaining Ring
*	20 Auxiliary Pilot Plug
21	Valve Body Stud
22	Guide Bushing
23	Packing Follower
●	24 Cage Gasket
⊗ ●	31 Tec Seal
○ ●	35 Ni-resist® Seal Ring
★ ●	40 PTFE Seal Ring
★ ●	41 Nordel® Backup Ring
□ ●	45 Graphite Seal Ring
●	46 Ni-resist® Backup Ring
75	Double cage
76	Pin

*	For 41405 Series Valves Only
+	For all Valves Sizes above 450°F (232°C)
★	For 41605 Series Valves Only
●	Recommended Spare Parts
□	For 41905 Series Valves Only
○	For 41405 / 41505 Series Valves Only
⊗	For 41305 Series Valves Only

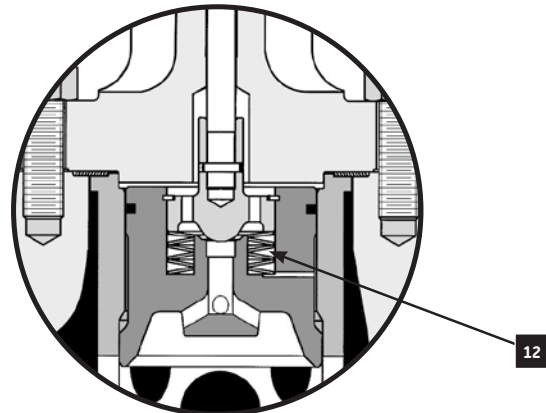

Pilot Balanced Construction Model 41405
Sizes 2" to 4" shown

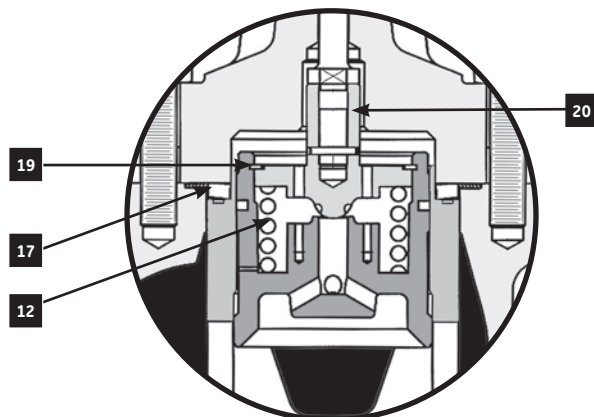

Pilot Balanced Construction Model 41405
Applications above 450°F (232°C) to 1050°F (566°C)
Sizes 6" to 18" shown

Materials of Construction

Models 41X15, 41X25, 41X35, 41X45, 41X55, & 41X95
Standard Carbon Steel Version

Ref. No	Temperature Range		-20°F (-29°C)	450°F (232°C)	650°F (343°C)	800°F (427°C)
	Description		Standard Materials			
1	Plug Stem		17-4 PH St. St. ASTM A564 GR 630			See Optional Materials
2	Packing Flange Stud		304 St. St. ASTM A193 GR B8			
3	Packing Flange Nut		304 St. St. ASTM A194 GR 8			
4	Packing Flange		Carbon Steel ASTM A105 Zinc Plated			
5	Packing Spacer		303 St. St. ASTM A582 TY 303			
6	Packing		PTFE / Carbon Fiber (ANSI Class 150-900) PTFE / Carbon and Graphite Wiper Rings (ANSI Class 1500 and 2500)			See Optional Materials
7	Valve Bonnet		Carbon Steel ASTM A216 Grade WCC			
8	Valve Body Nut		Carbon Steel ASTM A194 GR 2H			
9	Plug Stem Pin		316 St. St. ASTM A479 TY 316			
10	Valve Body Gasket		316L St. St. w/Flexible Graphite Filler (Spiral Wound)			
12	Pilot Spring(s) (41405 Only)	2" to 4"	Inconel X-750 AMS 5598 (Stacked Washers)			
		6" to 16"	Inconel X-750 ASTM B637 GR 688			
13	Seat Ring		410 St. St. ASTM A479 TY 410 Hardened			See Optional Materials
14	Seat Ring Gasket		316L St. St. w/Flexible Graphite Filler (Spiral Wound)			
15	Valve Plug		17-4 PH St. St. ASTM A747 GR CB7CU-1 Condition H1075			See Optional Materials
16	Cage		Martensitic St. St. ASTM A487 GR CA6NM CL B Hard Chrome Plated			
17	Conical Spring ⁽¹⁾ (6" to 24")		See Note 1	17-4 PH ASTM A564 GR 630 Condition H1075	Inconel X-750 ASTM B637 + Shot Peening	
18	Valve Body		Carbon Steel ASTM A216 Grade WCC			
19	Retaining Ring (41405 Only)		Inconel X-750 AMS 5598			
20	Auxiliary Pilot Plug (41405 Only)	2" to 4"	410 St. St. ASTM A479 TY 410 Hardened			
		6" to 16"	Martensitic St. St. ASTM A487 GR CA6NM CL B with Chrome Plated Guide and Hardfaced Seat			
21	Valve Body Stud		Alloy Steel ASTM A193 GR B7			
22	Guide Bushing		440C St. St. ASTM A276 TY 440C			
23	Packing Follower		Solution Annealed 316L St. St. Hrc 22 Maximum			
-	Internal Diffuser ⁽²⁾ (6" to 24")		316 St. St. ASTM A479 TY 316 with Hardfaced Seat			
24	Cage Gasket ⁽³⁾		316L St. St. w/Flexible Graphite Filler (Spiral Wound)			See Note 3
30	Retainer		17-4 PH St. St. H1075			
31	Seal Ring	See Page 20				
35						
40						
41						
45						
46						

Notes: 1. Conical spring only required for valve sizes 6" to 24" for applications > 450°F (232°C).

2. Internal Diffuser includes an internal 316SS Seat Ring with hardfaced seat. This part replaces the Seat Ring (Ref. No. 13) when this option is selected. See graphic on page 15.

3. Cage gasket only required for valve sizes 6" to 24" for applications ≤ 450°F (232°C) and all applications for 2" to 6" ANSI 2500 Class ratings only.

Review use of optional materials and configurations for temperature ranges indicated. Standard materials listed may still be applicable depending on specific service conditions. Consult Masoneilan for appropriate material combinations.

Materials of Construction

Models 41X15, 41X25, 41X35, 41X45, 41X55, & 41X95
Standard Stainless Steel Version⁽¹⁾

Ref. No	Temperature Range	-320°F (-196°C)	-148°F (-100°C)	-50°F (-46°C)	-20°F (-29°C)	450°F (232°C)	650°F (343°C)	800°F (427°C)	850°F (454°C)	950°F (510°C)	1050°F (566°C)	
		Standard Materials										
1	Plug Stem	See Optional Materials		316 St. St. ASTM A479 TY 316			See Optional Materials					
7 18	Valve Bonnet ⁽²⁾ Valve Body	316 St. St. ASTM A351 GR CF8M										
13	Seat Ring	316 St. St. ASTM A479 TY 316 with Hardfaced Seat										
15	Valve Plug	316 St. St. ASTM A479 TY 316 with Hardfaced Seat										
16	Cage	316 St. St. ASTM A479 TY 316 Chrome-Plated					See Optional Materials					
17	Conical Spring (6" to 16") ⁽³⁾	See Optional Materials			Inconel X-750 ASTM B637 + Shot Peening							
20	Auxiliary Pilot Plug (41405 Only)	316 St. St. ASTM A479 TY 316 with Chrome Plated Guide and Hardfaced Seat										
22	Guide Bushing	316 St. St. ASTM A479 TY 316 with Hardfacing Stellite or Equivalent 6 UNS 30006 (HRC 22 Max.)										
21	Valve Body Stud				ASTM A193 GR B7 - ZINC PLATING		A 193 Gr B7		ASTM A 193 Gr B16			
		ASTM A320 GR L7 ZINC PLATING										
		ASTM A 193 GR B8 class 2 (optional for 2" and 3" ASME class 300 and 600 only)										
		ASTM A453 GRADE 660 or ASTM A193 GRADE B8RA ⁽⁴⁾										
8	Valve Body Nut				ASTM A194 GR 2H - ZINC PLATING		A 194 Gr 2H					
		ASTM A194 GR 7 - ZINC PLATING					ASTM A 194 Gr 7					
		ASTM A 194 Gr 8 (optional for 2" and 3" ASME class 300 and 600 only)										
		ASTM A 194 Gr 8 ⁽⁴⁾										
30	Retainer	17-4 PH St. St. H1075 Hardfacing Stellite No. 6 on 316 St. St.										

- Notes: 1. Materials for other components are same as listed for Standard Carbon Steel Version.
 2. Extension bonnet : use a low temperature extension bonnet between -46°C and -100°C. Use a cryogenic bonnet between -101°C and -196°C.
 3. Conical spring only required for valve sizes 6" to 24" for applications > 450°F (232°C).
 4. Bolting must be checked by the Engineering Department.

Optional Configurations and Materials

Ref. No.	Temperature Range	-320°F (-196°C)	-100°F (-73°C)	-50°F (-46°C)	-20°F (-46°C)	650°F (343°C)	800°F (427°C)	1050°F (566°C)	
		Optional Materials							
1	Plug Stem	A286 Super Alloy ASTM A638 GR 660							
6	Packing	PTFE / Carbon Fiber							
		LE* Packing ⁽¹⁾							
		Flexible Graphite							
7 18	Valve Bonnet Valve Body	Chrome-Moly Steel ASTM A217 Grade WC6 or Grade WC9							
13	Seat Ring	Carbon Steel ASTM A 352 Grade LCC							
13	Seat Ring	2" to 4"		316 St. St. ASTM A479 TY 316 with Hardfaced Seat					
		6" to 16"		Martensitic St. St. ASTM A487 GR CA6NM CL A with Hardfaced Seat					
15	Valve Plug	Martensitic St. St. ASTM A487 GR CA6NM CL B Nitride							
16	Cage	Martensitic St. St. ASTM A487 GR CA6NM CL B Nitrided							
		316 St. St. ASTM A479 TY 316 Nitrided							
20	Auxiliary Pilot Plug (2" to 4") (41405 Only)	Martensitic St. St. ASTM A487 GR CA6NM CL B with Chrome Plated Guide and Hardfaced Seat							

- Notes: 1. LE Packing for low emissions applications is limited to the maximum operating pressure and temperature range shown in Figure 1.
 Consult GE for material combinations for temperatures below -20°F (-29°C) or above 800°F (427°C).

Review use of optional materials and configurations for temperature ranges indicated. Standard materials listed may still be applicable depending on specific service conditions. Consult Masoneilan for appropriate material combinations.

Materials of Construction

Optional Bolting Materials

Ref. No	Temperature Range	-320°F (-196°C) to -150°F (-101°C)	-150°F (-101°C) to -20°F (-29°C)	850°F (454°C) to 950°F (510°C)	950°F (510°C) to 1050°F (566°C)
	Description	Optional Materials			
8	Valve Body Nut ⁽¹⁾	304 SS ASTM A194 Grade 8	Alloy Steel ASTM A194 Grade 4	Alloy Steel ASTM A194 Grade 8	304 SS ASTM A194 Grade 8
21	Valve Body Stud ⁽¹⁾	Super Alloy ASTM A453 Grade 660	Alloy Steel ASTM A320 Grade L7	Alloy Steel ASTM A193 Grade B16	Super Alloy ASTM A453 Grade 660

Note: 1. Use following materials for 2" and 3" sizes ANSI Class 300/600 at temperatures below -20°F (-29°C).
 Studs - 304 SS ASTM A193 Grade B8 Class 2 • Nuts - 304 SS ASTM A194 Grade 8.

Pressure and Temperature Rating of LE* Packing

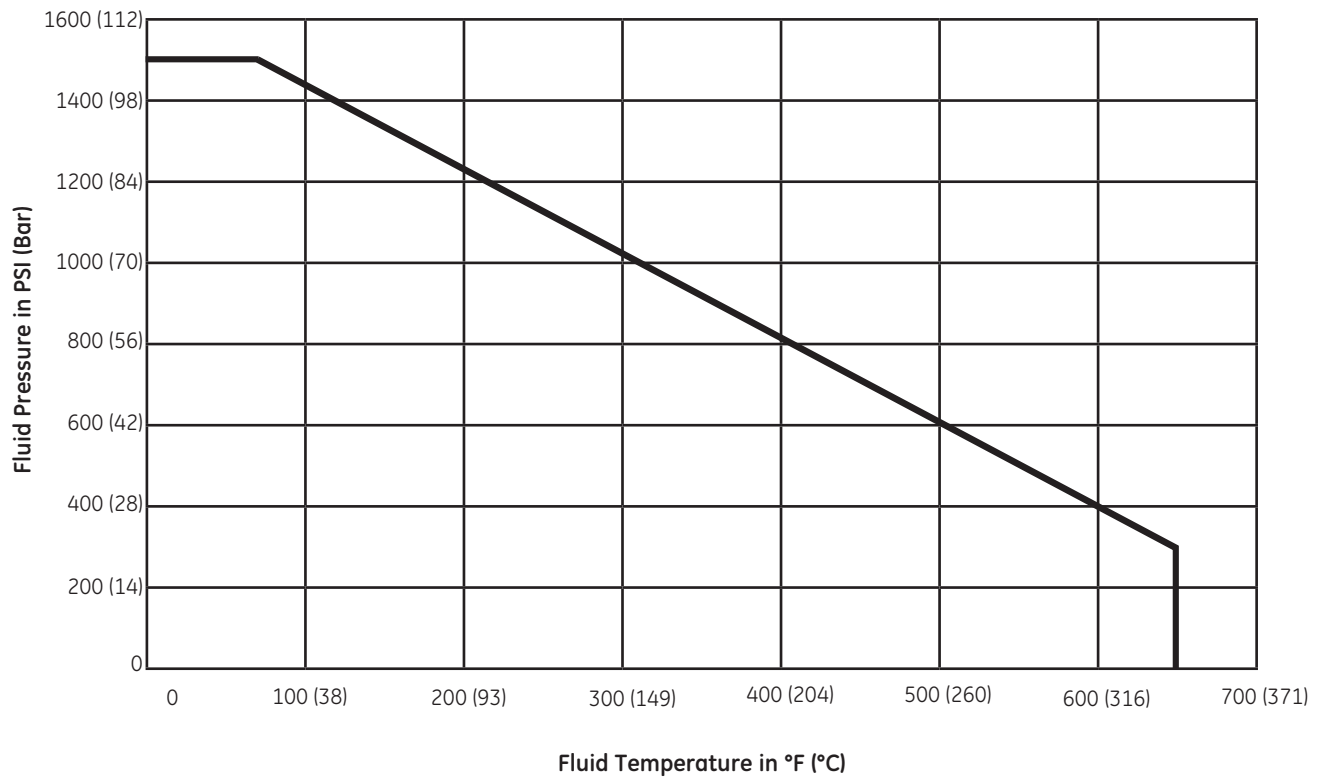

Figure 1

Materials of Construction

NACE⁽¹⁾ Configuration and Material Options
Models 41X15, 41X25, 41X35, 41X45, 41X55, & 41X95

Ref.No	Temperature Range		Standard and Optional Materials
	-20°F (-29°C) 650°F (343°C)		
Description			
1	P lug Stem		316 St. St. ASTM A479 TY 316 (HRC 22 Max.) Super Alloy ASTM A638 GR 660 (HRC 35 Max.)
2	Packing Flange Stud		304 St. St. ASTM A193 GR B8 ⁽²⁾ 304 St. St. ASTM A193 Gr B8 ⁽³⁾ (HRC 22 Max.)
3	Packing Flange Nut		304 St. St. ASTM A194 GR 8 ⁽²⁾ 304 St. St. ASTM A194 GR 8A ⁽³⁾ (HRC 22 Max.)
4	Packing Flange		Corrosion Protected Carbon Steel (HRC 22 Max.)
5	Packing Spacer		304 St. St. ASTM A479 TY 304
6	Packing		PTFE / Carbon Fiber
7	Valve Bonnet		Carbon Steel ASTM A216 Grade WCC (HRC 22 Max.) Carbon Steel ASTM A105 (HRC 22 Max.) 316 St. St. ASTM A351 Gr CF8M (HRC 22 Max.)
8	Valve Body Nut		Alloy Steel ASTM A194 GR 2H ⁽²⁾ Alloy Steel ASTM A194 Gr 2HM ⁽³⁾
9	Plug Stem Pin		316 St. St. ASTM A479 TY 316 (HRC 22 Max.)
10	Valve Body Gasket		316L St. St. w/Flexible Graphite Filler (Spiral Wound)
12	Pilot Spring(s) (41405 Only)	2" to 4"	Inconel X-750 AMS 5598 (HRC 50 Max.)
		6" to 16"	Inconel X-750 ASTM B637 GR 688 (HRC 50 Max.)
13	Seat Ring		316 St. St. ASTM A479 TY 316 with Hardfaced Seat (HRC 22 Max.)
14	Seat Ring Gasket		316L St. St. w/Flexible Graphite Filler (Spiral Wound)
15	Valve Plug		316 St. St. ASTM A479 TY 316 with Hardfaced Seat (HRC 22 Max.) Martensitic St. St. ASTM A487 GR CA6NM CL B (HRC 22 Max.)
16	Cage		316 St. St. ASTM A479 TY 316 Hard Chrome Plated (HRC 22 Max.) Martensitic St. St. ASTM A487 GR CA6NM CL B Hard Chrome Plated (HRC 23 Max.)
17	Conical Spring (6" to 24")		Inconel X-750 ASTM B637 + Shot Peening
18	Valve Body		Carbon Steel ASTM A216 Grade WCC (HRC 22 Max.) 316 St. St. ASTM A351 Gr CF8M (HRC 22 Max.)
19	Retaining Ring (41405 Only)		Inconel X-750 AMS 5598 (HRC 50 Max.)
20	Auxiliary Pilot Plug (41405 Only)		316 St. St. ASTM A479 TY 316 with Hardfaced Seat (HRC 22 Max.) Martensitic St. St. ASTM A487 GR CA6NM CL B Chrome Plated Guide and Hardfaced Seat (HRC 23 Max.)
21	Valve Body Stud		Alloy Steel ASTM A193 GR B7 ⁽²⁾ Alloy Steel ASTM A193 Gr B7M ⁽³⁾
22	Guide Bushing		Stellite Equivalent 6 UNS 30006 (HRC 22 Max.) 316 St. St. ASTM A479 TY 316 with Hardfacing (HRC 22 Max.)
23	Packing Follower		316 St. St. ASTM A479 TY 316 (HRC 22 Max.)
--	Internal Diffuser (6" to 24") (Not Shown)		316 St. St. ASTM A479 TY 316 with Hardfaced Seat (HRC 22 Max.)
24	Cage Gasket (6" to 24") ⁽⁴⁾		316L St. St. w/Flexible Graphite Filler (Spiral Wound)
30	Retainer		CA6NM ASTM 487 Gr CA 6 NM Class B Hardfacing Stellite No. 6 on 316 St. St.
31	Seal Ring ⁽⁵⁾		See Page 20
35			
40			
41			
45			
46			
--	Drive Nut (Not Shown)		Carbon Steel SAE 1117 ⁽²⁾ Carbon Steel ASTM A105 or SAE 1010-1025 ⁽³⁾

- Notes: 1. Standard materials and processes are in accordance with the requirements of NACE specification MR0103. Applications requiring compliance to MR0175-2003 or ISO15156 must be reviewed by Masoneilan.
2. Materials designated for these parts conform to NACE Class III bolting requirements. (Non-Exposed)
3. Materials designated for these parts conform to NACE Class I or Class II bolting requirements. (Exposed)
4. Cage gasket only required for valve sizes 6" to 24" for applications ≤ 450°F (232°C) and all applications for 2" to 6" ANSI 2500 Class ratings only.
5. Seal ring materials for Model 41605 (PTFE Seal Ring) will be replaced with Glass-Reinforced PTFE External Seal Ring (Ref. No. 40) and Viton Internal Seal Ring (Ref. No. 41).
Maximum temperature for Models 41305 and 41605 limited to 450°F (232°C).

Trim Types

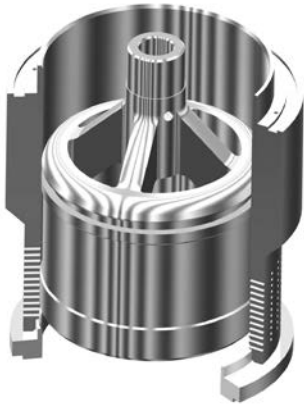

Models 41335 - 41535 - 41635 - 41935
 Single Stage Low Noise Trim FTO
 Anti-Cavitation Trim FTC

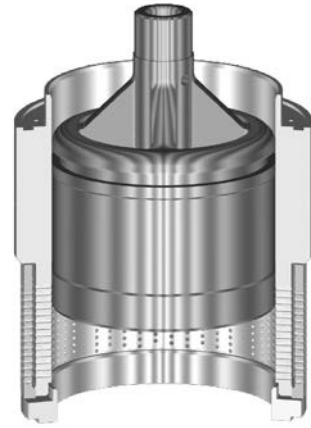

Models 41355 - 41555 - 41655 - 41955
 Multi-Stage Low Noise Trim FTO

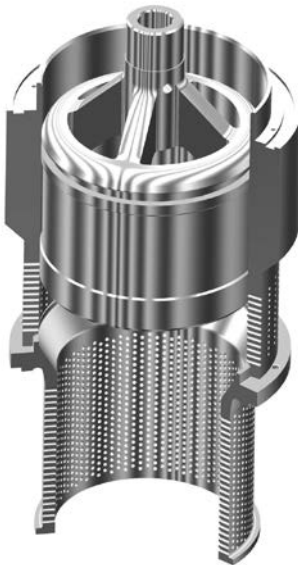

Model 41045
 Single Stage with Internal Diffuser
 (Sizes 6" - 24")



Models 41335 - 41595 - 41695 - 41995
 Single Stage Low Noise Trim FTO
 Anti-Cavitation Trim FTC

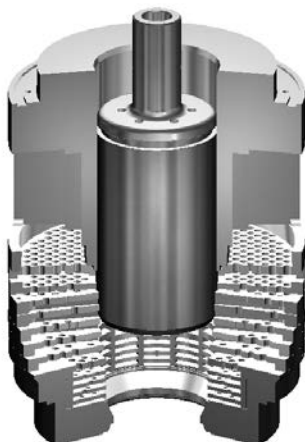

Model 41365 - 41375
 High Pressure Anti-Cavitation VRT

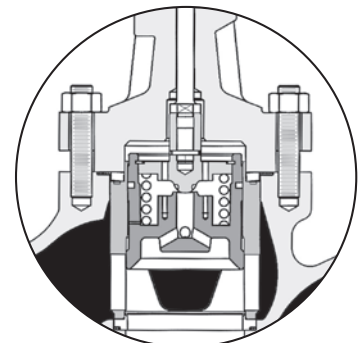

Model 41405
 Pilot Balanced Construction FTC

Seal Ring Construction

Model 41305

Seal Type:
Pressure Energized
Polymeric

Leakage:
Class IV Standard
(Class V Optional)

Temperature:
-148°F (-100°C) to
+450°F (+232°C)

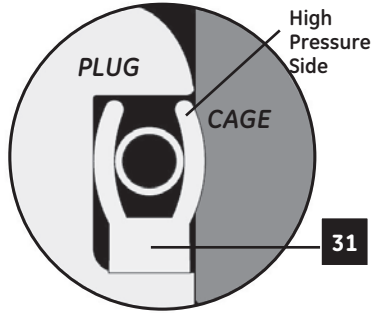

Seal Shown in FTO Orientation

Models 41405 and 41505

Seal Type:
Metal

Leakage:
From Class II to
Class V (with pilot)

Temperature:
-320°F (-196°C) to
+1050°F (+566°C)

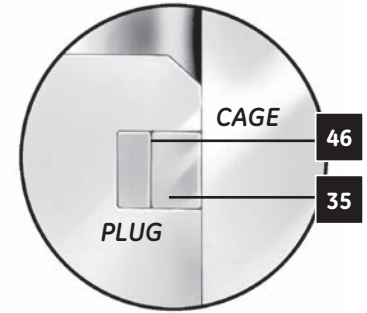

Model 41305⁽³⁾

Optional High
Temperature Version

Seal Type:
Pressure Energized
Polymeric

Leakage:
Class IV Standard

Temperature:
+450°F (+232°C) to
+600°F (+316°C)

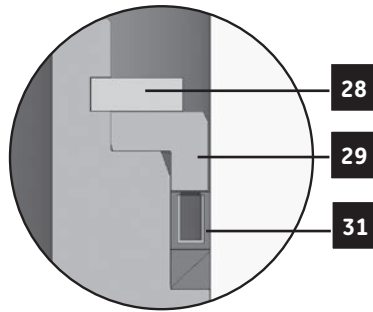

Model 41605

Seal Type:
TFE and Resilient Inner

Leakage:
Class IV Standard

Temperature:
-20°F (-29°C) to
+300°F (+149°C)

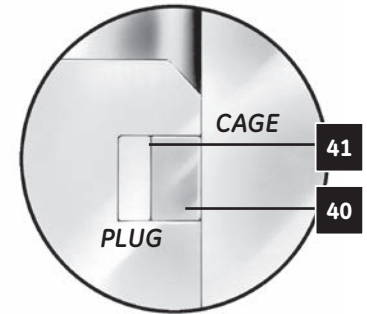

Model 41305⁽⁴⁾ (5)

Optional High
Temperature Version (non VRT)

Seal Type:
Pressure Energized
Polymeric

Leakage:
Class IV Standard
(Class V Optional)

Temperature:
-148°F (-100°C) to
+575°F (+302°C)

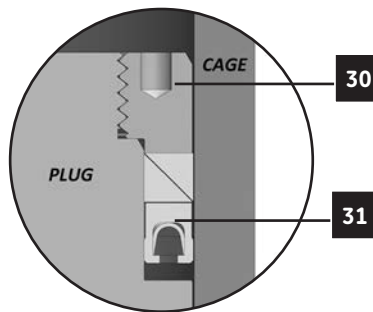

Model 41905

Seal Type:
Graphite and Metal Inner

Leakage:
Class III and
Class IV Standard

Temperature:
-320°F (-196°C) to
+850°F (+454°C)

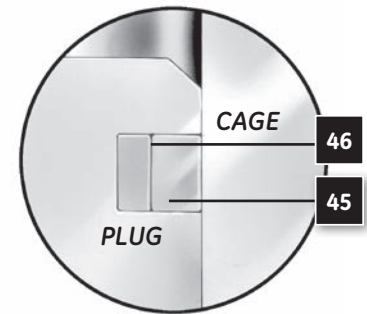

Ref. No.	Temperature Range	-320°F (-196°C)	-148°F (-100°C)	-20°F (-29°C)	+300°F (+149°C)	+450°F (+232°C)	+600°F (+316°C)	+650°F (+343°C)	+850°F (+454°C)	+1050°F (+566°C)	
		Materials									
31	Seal Ring	PTFE + 25% Graphite and ELGILOY Spring				Fluoroly A21 ⁽³⁾					
	Seal Ring										
35	External Seal Ring	NiResist ASTM A439 Type D3						Nitrided CA6NM			
40	External Seal Ring	Bronze PTFE									
		Glass Reinforced PTFE ⁽¹⁾									
41	Internal Seal Ring	Nordel									
		Viton ^{(1) (2)}									
45	External Seal Ring	Graphite									
46	Internal Seal Ring	NiResist ASTM A439 Type D3									

- Notes: 1. Optional materials for NACE service. Viton not recommended for water or steam service.
2. Viton is recommended for oil and hydrocarbon service.
3. Optional high temperature seal for 41365 and 41375 VRT.
4. Optional high temperature seal for 41305 non-VRT applications.
5. FTO & FTC capable.

Materials of Construction

Models 41365 & 41375 VRT

Ref. No	Part Name
1	Plug Stem
2	Packing Flange Stud
3	Packing Flange Nut
4	Packing Flange
5	Packing Spacer
• 6	Packing
7	Valve Bonnet
8	Valve Body Nut
9	Plug Stem Pin
• 10	Valve Body Gasket
• 11	Seal Ring
13	Seat Ring
• 14	Seat Ring Gasket
15	Valve Plug
16	Cage
18	Valve Body
21	Valve Body Stud
22	Guide Bushing
23	Packing Follower
• 24	Cage Gasket
28	Retaining Ring
29	Retaining Ring
37	Stack
• Recommended Spare Parts	

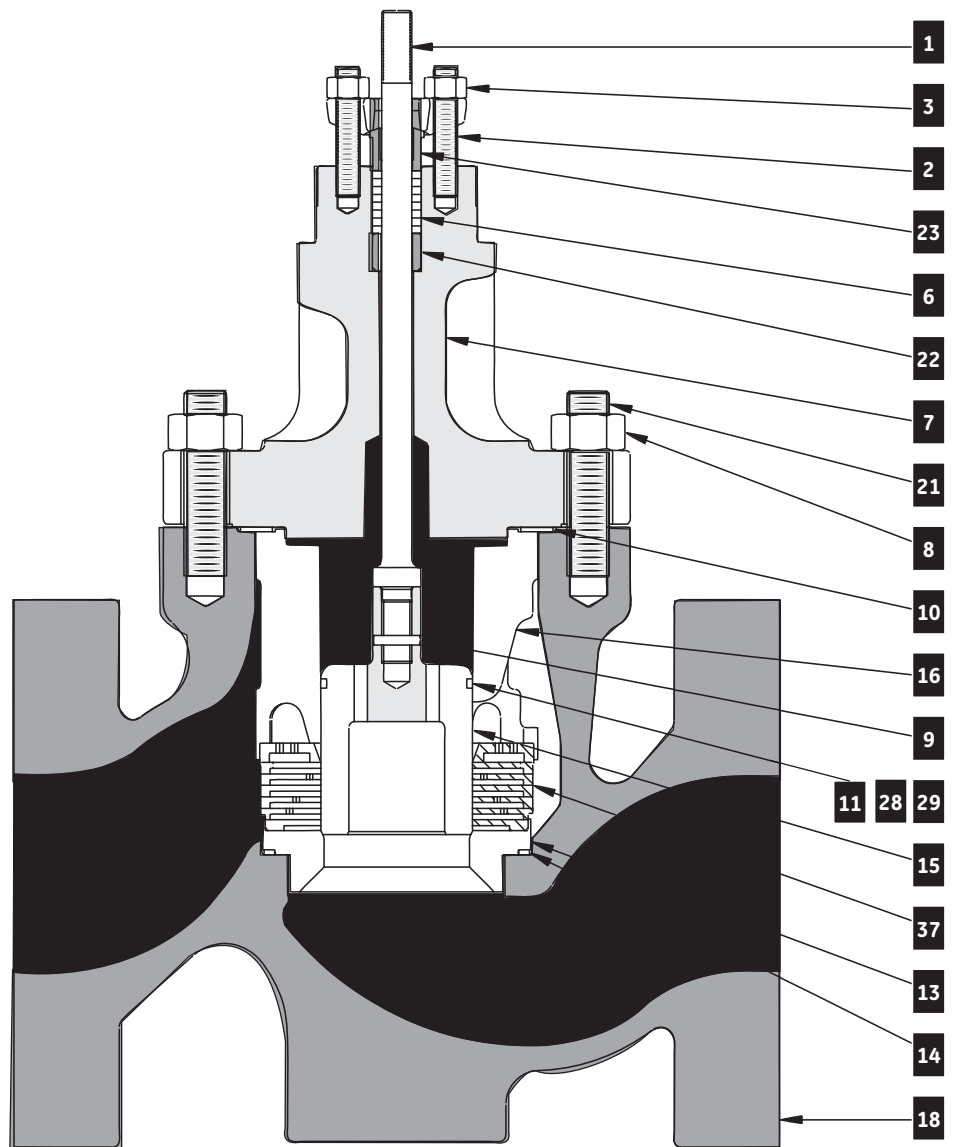

Materials of Construction

Models 41365 & 41375 VRT
Standard Carbon Steel Version

Ref. No	Temperature Range		-20°F (-29°C)	450°F (232°C)	600°F
	Description		Standard Materials (316°C)		
1	Plug Stem		174 PH St. St. ASTM A564 GR 630		
2	Packing Flange Stud		304 St. St. ASTM A193 GR B8		
3	Packing Flange Nut		304 St. St. ASTM A194 GR 8		
4	Packing Flange		Carbon Steel ASTM A105 Zinc Plated		
5	Packing Spacer		303 St. St. ASTM A582 TY 303		
6	Packing		Kevlar PTFE (Crane 285K) (ANSI Class 150-900) PTFE/Carbon and Graphite Wiper Rings (ANSI Class 1500 and 2500)		
7	Valve Bonnet		Carbon Steel ASTM A216 Grade WCC		
8	Valve Body Nut		Carbon Steel ASTM A194 GR 2H		
9	Plug Stem Pin		316 St. St. ASTM A479 TY 316		
10	Valve Body Gasket		316L St. St. w/Flexible Graphite Filler (Spiral Wound)		
11	Seal Ring	Standard	PTFE + Graphite (25%) with ELGILOY Spring		
		Optional			Fluoroly A21
13	Seat Ring		410 St. St. ASTM A479 TY 410 Hardened		
14	Seat Ring Gasket		316L St. St. w/Flexible Graphite Filler (Spiral Wound)		
15	Valve Plug	3" to 6"	440C St. St. ASTM A276 TY 440C		
		8" and 10"	17-4 PH St. St. ASTM A747 Gr CB7CU-1 Condition H900		
16	Cage		Martensitic St. St. ASTM A487 GR CA6NM CL B Hard Chrome Plated		
18	Valve Body		Carbon Steel ASTM A216 Grade WCC		
21	Valve Body Stud		Alloy Steel ASTM A193 GR B7		
22	Guide Bushing		440C St. St. ASTM A276 TY 440C		
23	Packing Follower		303 St. St. ASTM A582 TY 303		
24	Cage Gasket ⁽³⁾		316L St. St. w/Flexible Graphite Filler (Spiral Wound)		
28	Retaining Ring				ASTM A564 Gr 632 H950 St. St
29	Retaining Ring				316 St. St. ASTM A479 TY 316
30	Retaining Ring		Hardfacing Stellite No.6 on 316 Stainless Steel		
			ASTM A487 Gr CA 6 NM Class B		
			17-4 PH Stainless Steel H1075		
			ASTM A479 UNS S31803 + Chrome Plating		
			ASTM A479 UNS S31803 + Hardfacing		
37	Stack		410 St. St. QT ASTM A743 Grade CA15		

Materials of Construction

Models 41356 & 41375 VRT
Standard Stainless Steel Version

Ref. No	Temperature Range	20°F (-29°C)	450°F (232°C)
	Description	Standard Materials	
1	Plug Stem	A286 Super Alloy ASTM A638 GR 660	
2	Packing Flange Stud	304 St. St. ASTM A193 GR B8	
3	Packing Flange Nut	304 St. St. ASTM A194 GR 8	
4	Packing Flange	Carbon Steel ASTM A105 Zinc Plated	
5	Packing Spacer	303 St. St. ASTM A582 TY 303	
6	Packing	Kevlar PTFE (Crane 285K) (ANSI Class 150-900) PTFE/Carbon and Graphite Wiper Rings (ANSI Class 1500 and 2500)	
7	Valve Bonnet	316 St. St. ASTM A351 GR CF8M	
8	Valve Body Nut	Carbon Steel ASTM A194 GR 2H	
9	Plug Stem Pin	316 St. St. ASTM A479 TY 316	
10	Valve Body Gasket	316L St. St. w/Flexible Graphite Filler (Spiral Wound)	
11	Seal Ring	PTFE + Graphite (25%) with ELGILOY Spring	
13	Seat Ring	316 St. St. ASTM A479 TY 316 with Hardfaced Seat	
14	Seat Ring Gasket	316L St. St. w/Flexible Graphite Filler (Spiral Wound)	
15	Valve Plug	316 St. St. ASTM A479 TY 316 with Hardfaced Seat	
16	Cage	316 St. St. ASTM A479 TY 316 Chrome-Plated	
18	Valve Body	316 St. St. ASTM A351 GR CF8M	
21	Valve Body Stud	Alloy Steel ASTM A193 GR B7	
22	Guide Bushing	316 St. St. ASTM A479 TY 316 with Hardfacing	
23	Packing Follower	303 St. St. ASTM A582 TY 303	
24	Cage Gasket ⁽³⁾	316L St. St. w/Flexible Graphite Filler (Spiral Wound)	
28	Retaining Ring	ASTM A564 Gr 632 H950 St. St.	
29	Retaining Ring	316 St. St. ASTM A479 TY 316	
37	Stack	410 St. St. QT ASTM A743 Grade CA15	

Note: Materials for other components are as listed for Standard Carbon Steel Version.

Materials of Construction

NACE⁽¹⁾ Configuration and Material Options
 Models 41356 & 41375 VRT

Ref. No	Temperature Range		-20°F (-29°C)	450°F (232°C)	600°F (316°C)
	Description		Standard Materials		
1	Plug Stem		A286 Super Alloy ASTM A638 GR 660		
2	Packing Flange Stud		304 St. St. ASTM A193 GR B8 ⁽²⁾		
			304 St. St. ASTM A193 GR B8 ⁽³⁾ (HRC 22 Max.)		
3	Packing Flange Nut		304 St. St. ASTM A194 GR 8 ⁽²⁾		
			304 St. St. ASTM A194 GR 8A ⁽³⁾ (HRC 22 Max.)		
4	Packing Flange		Corrosion Protected Carbon Steel (HRC 22 Max.)		
5	Packing Spacer		304 St. St. ASTM A479 TY 304		
6	Packing		Kevlar PTFE (Crane 285K) (ANSI Class 150-900) PTFE/Carbon and Graphite Wiper Rings (ANSI Class 1500 and 2500)		
7	Valve Bonnet		Carbon Steel ASTM A216 Grade WCC (NRC 22 Max.)		
			316 St. St. ASTM A351 Gr CF8M (HRC 22 Max)		
8	Valve Body Nut		Carbon Steel ASTM A194 GR 2H ⁽²⁾		
			Carbon Steel ASTM A194 GR 2HM ⁽³⁾		
9	Plug Stem Pin		316 St. St. ASTM A479 TY 316 (HRC 22 Max.)		
10	Valve Body Gasket		316L St. St. w/Flexible Graphite Filler (Spiral Wound)		
11	Seal Ring	Standard	PTFE + Graphite (25%) with ELGILOY Spring		
		Optional			Fluoroly A21
13	Seat Ring		316 St. St. ASTM A479 TY 316 with Hardfaced Seat (HRC 22 Max.)		
14	Seat Ring Gasket		316L St. St. w/Flexible Graphite Filler (Spiral Wound)		
15	Valve Plug		316 St. St. ASTM A479 TY 316 with Hardfaced Seat (HRC 22 Max.)		
16	Cage		Martensitic St. St. ASTM A487 GR CA6NM CL B Hard Chrome Plated		
18	Valve Body		Carbon Steel ASTM A216 Grade WCC (NRC 22 Max.)		
			316 St. St. ASTM A351 Gr CF8M (HRC 22 Max)		
21	Valve Body Stud		Alloy Steel ASTM A193 GR B7 ⁽²⁾		
			Alloy Steel ASTM A 193 GRADE B7M		
22	Guide Bushing		316 St. St. ASTM A479 TY 316 with Hardfacing		
23	Packing Follower		316 St. St. ASTM A479 TY 316 (HRC 22 Max.)		
24	Cage Gasket ⁽³⁾		316L St. St. w/Flexible Graphite Filler (Spiral Wound)		
28	Retaining Ring			ASTM A564 Gr 632 H950 St. St	
29	Retaining Ring			316 St. St. ASTM A479 TY 316	
37	Stack		Inconel 718 ASTM B637 Solution Annealed and Precipitation Hardened		

- Notes: 1. Standard materials and processes are in accordance with the requirements of NACE specification MR0103. Applications requiring compliance to MR0175-2003 or ISO15156 must be reviewed by GE.
 2. Materials designated for these parts conform to NACE Class III bolting requirements. (Non-Exposed)
 3. Materials designated for these parts conform to NACE Class 1 or Class II bolting requirements. (Exposed)

Dimensions (inches)

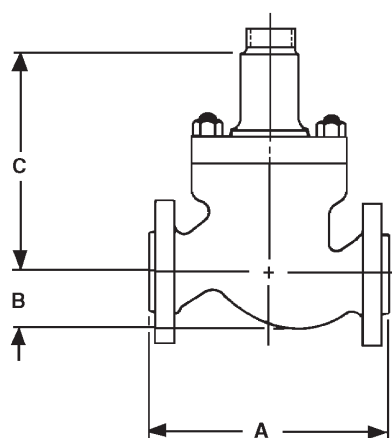

Flanged

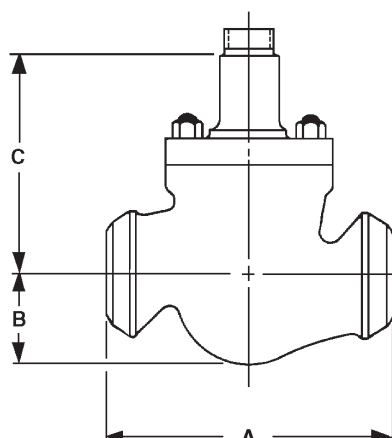

Butt, Socket Weld
or Screwed Ends

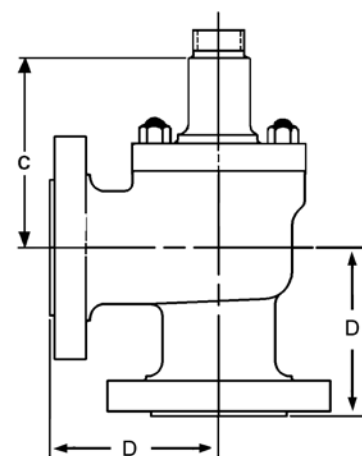

Angle

Pressure Class		A										
		ANSI Class 150 and equivalent PN		ANSI Class 300 and equivalent PN			ANSI Class 600 and equivalent PN			ANSI Class 900 and equivalent PN		
Valve Size		RF	RTJ	BW & SW	RF	RTJ	BW & SW	RF	RTJ	BW & SW	RF	RTJ
in.	mm											
2	50	10.00	10.50	11.26	10.50	11.12	11.26	11.24	11.38	14.76	14.74	14.88
3	80	11.75	12.25	13.27	12.50	13.12	13.27	13.25	13.37	18.11	17.38	17.48
3x2 ⁽²⁾	80x50	"	"	"	"	"	"	"	"	(1)	(1)	(1)
4	100	13.86	14.33	15.51	14.50	15.12	15.51	15.50	15.62	20.87	20.12	20.24
4x2	100x50	"	"	"	"	"	"	"	"	(1)	(1)	(1)
4x3	100x80	"	"	"	"	"	"	"	"	20.87	20.12	20.24
6	150	17.75	18.27	20	18.64	19.25	20.00	20.00	20.12	30.24	28.12	28.24
6x3	150x80	"	"	"	"	"	"	"	"	"	"	"
6x4	150x100	"	"	"	"	"	"	"	"	"	"	"
8	200	21.38	21.87	24.02	22.38	22.99	24.02	24	24.13	32.76	36.00	36.12
8x4	200x100	"	"	"	"	"	"	"	"	"	"	"
8x6	200x150	"	"	"	"	"	"	"	"	"	"	"
10	250	26.50	27.00	29.61	27.88	28.50	29.61	29.62	29.72	39.02	43.00	43.12
10x6	250x150	"	"	"	"	"	"	"	"	"	"	"
10x8	250x200	"	"	"	"	"	"	"	"	"	"	"
12	300	29.02	29.53	32.24	30.51	31.14	32.24	32.25	32.36	44.49	44.49	44.61
12x8	300x200	"	"	"	"	"	"	"	"	"	"	"
16	400	40.00	40.51	43.62	41.61	42.25	43.62	43.62	43.74	55.98	54.72	55.08
16x12	400x300	"	"	"	"	"	(1)	"	"	(1)	(1)	(1)
18	450	44.76	45.08	48.82	46.85	47.32	48.82 ⁽³⁾	51.50	51.97	64.72	58.03	58.50
20	500	65.43	65.91	71.14	67.09	67.80	74.41	69.57	69.80	84.72	71.06	71.57
24	600	78.70	79.21	86.22	80.94	81.81	94.33	83.46	83.86	-	-	-

Notes: 1. Consult GE.
 2. Ex. 3x2 size = valve with 3" body x standard 2" trim.
 3. Applies to Schedule 40 only. Schedule 80 Face to Face is 58.27 in.

Dimensions (inches)

Pressure Class		A			A			B max					C max				
		ANSI Class 1500 and equivalent PN			ANSI Class 2500 and equivalent PN			ANSI 150 / 300	ANSI 600	ANSI 900	ANSI 1500	ANSI 2500	ANSI 150 / 300	ANSI 600	ANSI 900	ANSI 1500	ANSI 2500
Valve Size		BW & SW	RF	RTJ	BW & SW	RF	RTJ										
inches	mm																
2	50	14.76	14.74	14.88	15.75	17.17	17.24	3.70	3.70	2.24	2.24	5.12	9.84	9.84	8.50	8.50	10.31
3	80	18.11	18.13	18.23	19.61	19.13	19.33	4.49	4.49	5.63	5.63	6.89	11.81	11.81	11.81	11.81	14.06
3x2	80x50 ⁽²⁾	(1)	(1)	(1)	(1)	(1)	(1)	4.57	4.57	5.63	5.63	-	9.88	9.88	10.39	10.39	-
4	100	20.87	20.88	21.00	22.64	23.66	23.98	5.51	5.51	6.26	6.26	7.87	12.99	12.99	12.99	12.99	14.76
4x2	100x50	(1)	(1)	(1)	(1)	(1)	(1)	5.51	5.51	6.06	6.06	-	10.28	10.28	10.08	10.08	-
4x3	100x80	20.87	20.88	21.00	(1)	(1)	(1)	5.51	5.51	6.26	6.26	-	12.68	12.68	12.68	12.68	-
6	150	30.24	30.24	30.47	32.24	29.33	29.45	7.80	7.80	8.54	8.54	10.35	15.35	15.35	15.35	15.35	15.39
6x3	150x80	"	"	"	(1)	(1)	(1)	7.48	7.48	6.30	6.30	-	12.68	12.68	12.60	12.60	-
6x4	150x100	"	"	"	(1)	(1)	(1)	7.48	7.48	6.30	6.30	-	13.46	13.46	13.27	13.27	-
8	200	32.76	38.25	38.62	40.51	35.12	35.67	7.32	7.52	7.52	8.07	11.81	19.53	19.53	20.51	20.51	17.72
8x4	200x100	"	"	"	(1)	(1)	(1)	8.74	8.74	6.69	6.69	-	14.41	14.41	12.99	12.99	-
8x6	200x150	"	"	"	(1)	(1)	(1)	8.74	8.74	6.77	6.77	-	17.05	17.05	15.35	15.35	-
10	250	39.02	46.00	46.38	50.00	42.72	43.54	8.66	8.98	9.06	9.61	14.25	21.65	21.65	22.44	22.44	24.21
10x6	250x150	"	"	"	(1)	(1)	(1)	9.13	9.13	9.09	9.09	-	18.46	18.46	15.35	15.35	-
10x8	250x200	"	"	"	(1)	(1)	(1)	9.13	9.13	8.58	8.74	-	19.65	19.65	20.51	20.51	-
12	300	44.49	47.95	48.58	55.98	46.93	47.76	12.80	13.19	13.58	14.17	16.30	24.41	24.41	24.65	24.65	24.90
12x8	300x200	(1)	(1)	(1)	(1)	(1)	(1)	9.53	9.53	9.84	9.84	-	19.53	19.53	20.51	20.51	-
16	400	55.98	59.37	60.24	72.44	-	-	17.32	17.72	18.11	19.09	17.36	27.32	27.32	31.69	31.69	27.52
16x12	400x300	(1)	(1)	(1)	(1)	-	-	17.72	17.72	17.83	18.78	-	25.59	25.59	27.40	27.40	-
18	450	72.05	61.34	61.81	-	-	-	20.43	20.91	20.91	21.97		33.62	33.62	39.13	42.09	
20	500	-	-	-	-	-	-	26.34	26.77	27.24			34.13	35.59	37.40		
24 ⁽³⁾	600	-	-	-	-	-	-	31.65	32.28				40.00	41.18			
24 ⁽⁴⁾	600	-	-	-	-	-	-	31.65	32.28				47.99	49.17			

- Notes: 1. Consult GE.
 2. Ex. 80x50 size = valve with 80mm body x standard 50mm trim.
 3. 11" Nominal stroke length
 4. 15" Nominal stroke length

Angle Body S/A (inches)

Pressure Class		D									
		ANSI Class 150 and equivalent PN		ANSI Class 300 and equivalent PN		ANSI Class 600 and equivalent PN		ANSI Class 900 and equivalent PN		ANSI Class 1500 and equivalent PN	
Valve Size		RF	RTJ	RF	RTJ	RF	RTJ	RF	RF	RF	RTJ
inches	mm										
2	50	5.15	5.38	5.27	5.58	5.78	5.84	7.27	7.35	7.27	7.35
3	80	5.92	6.17	6.29	6.61	7.04	7.12	8.89	8.97	9.28	9.36
4	100	7.71	7.94	8.04	8.34	8.53	8.61	10.38	10.46	10.78	10.86
6	150	8.34	8.59	8.77	9.09	11.02	11.07	12.04	12.10	13.89	14.01

Dimensions (mm)

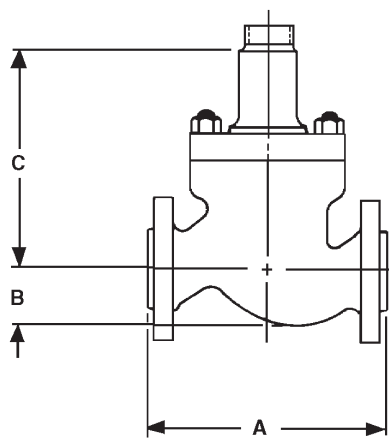

Flanged

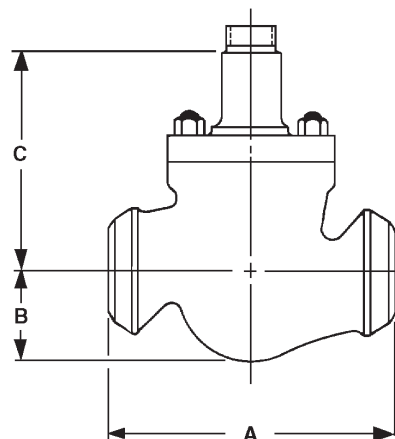

Butt, Socket Weld
or Screwed Ends

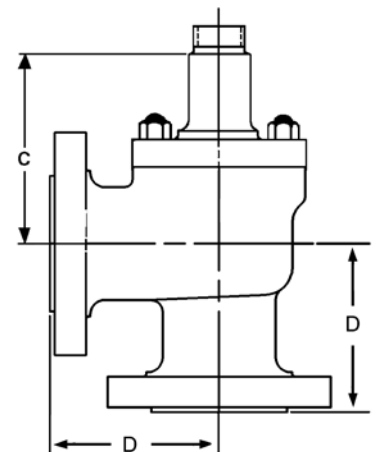

Angle

Pressure Class		A										
		ANSI Class 150 and equivalent PN		ANSI Class 300 and equivalent PN			ANSI Class 600 and equivalent PN			ANSI Class 900 and equivalent PN		
Valve Size		RF	RTJ	BW & SW	RF	RTJ	BW & SW	RF	RTJ	BW & SW	RF	RTJ
in.	mm											
2	50	254	266.5	286	266.5	282.5	286	285.5	289	375	374.5	378
3	80	298.5	311	337	317.5	333.5	337	336.5	339.5	460	441.5	444
3x2	80x50 ⁽²⁾	"	"	"	"	"	"	"	"	(1)	(1)	(1)
4	100	352	364	394	368.5	384	394	393.5	397	530	511	514
4x2	100x50	"	"	"	"	"	"	"	"	(1)	(1)	(1)
4x3	100x80	"	"	"	"	"	"	"	"	530	511	514
6	150	451	464	508	473	489	508	508	511	768	714	717
6x3	150x80	"	"	"	"	"	"	"	"	"	"	"
6x4	150x100	"	"	"	"	"	"	"	"	"	"	"
8	200	543	555.5	610	568.5	584	610	609.5	613	832	914.5	917.5
8x4	200x100	"	"	"	"	"	"	"	"	"	"	"
8x6	200x150	"	"	"	"	"	"	"	"	"	"	"
10	250	673	686	752	708	724	752	752	755	991	1092	1095
10x6	250x150	"	"	"	"	"	"	"	"	"	"	"
10x8	250x200	"	"	"	"	"	"	"	"	"	"	"
12	300	737	750	819	775	791	819	819	822	1130	1130	1133
12x8	300x200	"	"	"	"	"	"	"	"	"	"	"
16	400	1016	1029	1108	1057	1073	1108	1108	1111	1422	1390	1399
16x12	400x300	"	"	"	"	"	(1)	"	"	(1)	(1)	(1)
18	450	1137	1145	1240	1190	1202	1240 ⁽³⁾	1308	1320	1644	1474	1486
20	500	1662	1674	1807	1704	1722	1890	1767	1773	2152	1805	1818
24	600	1999	2012	2190	2056	2078	2396	2120	2130	-	-	-

Notes: 1. Consult GE.

2. Ex. 80x50 size = valve with 80mm body x standard 50mm trim.

3. Applies to Schedule 40 only. Schedule 80 Face to Face is 1480 mm.

Dimensions (mm)

Pressure Class		A			A			B max					C max				
		ANSI Class 1500 and equivalent PN			ANSI Class 2500 and equivalent PN			ANSI 150 / 300	ANSI 600	ANSI 900	ANSI 1500	ANSI 2500	ANSI 150 / 300	ANSI 600	ANSI 900	ANSI 1500	ANSI 2500
Valve Size		BW & SW	RF	RTJ	BW & SW	RF	RTJ										
mm	inches																
50	2	375	374.5	378	400	436	438	94	94	57	57	130	250	250	216	216	262
80	3	460	460.5	463	498	486	491	114	114	143	143	175	300	300	300	300	357
80x50 ⁽²⁾	3x2	(1)	(1)	(1)	(1)	(1)	(1)	116	116	143	143	-	251	251	264	264	-
100	4	530	530.5	533.5	575	601	609	140	140	159	159	200	330	330	330	330	375
100x50	4x2	(1)	(1)	(1)	(1)	(1)	(1)	140	140	154	154	-	261	261	256	256	-
100x80	4x3	530	530.5	533.5	(1)	(1)	(1)	140	140	159	159	-	322	322	322	322	-
150	6	768	768	774	819	745	748	198	198	217	217	263	390	390	390	390	391
150x80	6x3	"	"	"	(1)	(1)	(1)	190	190	160	160	-	322	322	320	320	-
150x100	6x4	"	"	"	(1)	(1)	(1)	190	190	160	160	-	342	342	337	337	-
200	8	832	971.5	981	1029	892	906	186	191	191	205	300	496	496	521	521	450
200x100	8x4	"	"	"	(1)	(1)	(1)	222	222	170	170	-	366	366	330	330	-
200x150	8x6	"	"	"	(1)	(1)	(1)	222	222	172	172	-	433	433	390	390	-
250	10	991	1168	1178	1270	1085	1106	220	228	230	244	362	550	550	570	570	615
250x150	10x6	"	"	"	(1)	(1)	(1)	232	232	231	231	-	469	469	390	390	-
250x200	10x8	"	"	"	(1)	(1)	(1)	232	232	218	222	-	499	499	521	521	-
300	12	1130	1218	1234	1422	1192	1213	325	335	345	360	415	620	620	626	626	632
300x200	12x8	(1)	(1)	(1)	(1)	(1)	(1)	242	242	250	250	-	496	496	521	521	-
400	16	1422	1508	1530	1840	-	-	440	450	460	485	441	694	694	805	805	699
400x300	16x12	(1)	(1)	(1)	(1)	-	-	450	450	453	477	-	650	650	696	696	-
450	18	1830	1558	1570	-	-	-	519	531	531	558		854	854	994	1069	
500	20	-	-	-	-	-	-	669	680	692			867	904	950		
600	24 ⁽³⁾	-	-	-	-	-	-	804	820				1016	1046			
600	24 ⁽⁴⁾	-	-	-	-	-	-	804	820				1219	1249			

Notes: 1. Consult GE.

2. Ex. 80x50 size = valve with 80mm body x standard 50mm trim.

3. 11" Nominal stroke length

4. 15" Nominal stroke length

Angle Body S/A (mm)

Pressure Class		D									
		ANSI Class 150 and equivalent PN		ANSI Class 300 and equivalent PN		ANSI Class 600 and equivalent PN		ANSI Class 900 and equivalent PN		ANSI Class 1500 and equivalent PN	
Valve Size		RF	RTJ	RF	RTJ	RF	RTJ	RF	RF	RF	RTJ
mm	inches										
50	2	131	137	134	142	147	148	185	187	185	187
80	3	150	157	160	168	179	181	226	228	236	238
100	4	196	202	204	212	217	219	264	266	274	276
150	6	212	218	223	231	280	281	306	307	353	356

Weights

Globe Style Body S/A Weights (lbs)

Valve Size		Flanged Connection						Threaded / Welded Connection			
in.	mm	ANSI Class 150 and equivalent PN	ANSI Class 300 and equivalent PN	ANSI Class 600 and equivalent PN	ANSI Class 900 and equivalent PN	ANSI Class 1500 and equivalent PN	ANSI Class 2500 and equivalent PN	ANSI Class 600 and equivalent PN	ANSI Class 900 and equivalent PN	ANSI Class 1500 and equivalent PN	ANSI Class 2500 and equivalent PN
2	50	99	99	88	121	121	320	88	88	88	(1)
3	80	176	187	187	265	287	518	165	220	220	(1)
3x2	80x50	143	154	165	198	220	-	132	154	154	-
4	100	231	254	265	463	496	860	209	386	397	(1)
4x2	100x50	176	198	209	331	364	-	154	254	265	-
4x3	100x80	209	220	243	397	430	-	187	331	331	-
6	150	397	430	518	893	1036	1653	408	750	816	(1)
6x3	150x80	320	364	441	739	893	-	342	595	661	-
6x4	150x100	353	386	474	805	948	-	364	650	717	-
8	200	772	827	937	1400	1698	2679	783	1146	1323	(1)
8x4	200x100	584	639	750	1157	1466	-	584	915	1091	-
8x6	200x150	628	683	794	1257	1554	-	628	1003	1179	-
10	250	1168	1257	1378	2227	2646	4806	1124	1863	2006	(1)
10x6	250x150	838	926	1047	1775	2194	-	794	1422	1554	-
12	300	1532	1631	2116	2932	4288	7176	1819	2458	3329	(1)
12x8	300x200	1135	1235	1720	2502	3671	-	1422	2028	2723	-
16	400	3274	3472	3847	6338	7959	-	3318	5666	6294	(1)
16x12	400x300	3009	3197	3395	5776	7363	-	2877	5093	5699	-
18	450	3583	3869	5192	8267	12765	-	4652	7507	11023	-
20	500	6989	7363	9160	11729	-	-	8311	11442	-	-
24 ⁽¹⁾	600 ⁽¹⁾	10659	11431	13702	-	-	-	13062	-	-	-
24 ⁽²⁾	600 ⁽²⁾	11343	12037	14429	-	-	-	13814	-	-	-

Globe Style Body S/A Weights (kg)

Valve Size		Flanged Connection						Threaded / Welded Connection			
mm	in.	ANSI Class 150 and equivalent PN	ANSI Class 300 and equivalent PN	ANSI Class 600 and equivalent PN	ANSI Class 900 and equivalent PN	ANSI Class 1500 and equivalent PN	ANSI Class 2500 and equivalent PN	ANSI Class 600 and equivalent PN	ANSI Class 900 and equivalent PN	ANSI Class 1500 and equivalent PN	ANSI Class 2500 and equivalent PN
50	2	45	45	40	55	55	145	40	40	40	(1)
80	3	80	85	85	120	130	235	75	100	100	(1)
80x50	3x2	65	70	75	90	100	-	60	70	70	-
100	4	105	115	120	210	225	390	95	175	180	(1)
100x50	4x2	80	90	95	150	165	-	70	115	120	-
100x80	4x3	95	100	110	180	195	-	85	150	150	-
150	6	180	195	235	405	470	750	185	340	370	(1)
150x80	6x3	145	165	200	335	405	-	155	270	300	-
150x100	6x4	160	175	215	365	430	-	165	295	325	-
200	8	350	375	425	635	770	1215	355	520	600	(1)
200x100	8x4	265	290	340	525	665	-	265	415	495	-
200x150	8x6	285	310	360	570	705	-	285	455	535	-
250	10	530	570	625	1010	1200	2180	510	845	910	(1)
250x150	10x6	380	420	475	805	995	-	360	645	705	-
300	12	695	740	960	1330	1945	3255	825	1115	1510	(1)
300x200	12x8	515	560	780	1135	1665	-	645	920	1235	-
400	16	1485	1575	1745	2875	3610	-	1505	2570	2855	(1)
400x300	16x12	1365	1450	1540	2620	3340	-	1305	2310	2585	-
450	18	1625	1755	2355	3750	5790	-	2110	3405	5000	-
500	20	3170	3340	4155	5320	-	-	3770	5190	-	-
600 ⁽¹⁾	24 ⁽¹⁾	4835	5185	6215	-	-	-	5925	-	-	-
600 ⁽²⁾	24 ⁽²⁾	5145	5460	6545	-	-	-	6266	-	-	-

Note: 1. Consult GE's Masoneilan

Weights

Angle Style Body S/A Weights (lbs)

Valve		Flanged Connection				
Size		ANSI Class 150 and equivalent PN	ANSI Class 300 and equivalent PN	ANSI Class 600 and equivalent PN	ANSI Class 900 and equivalent PN	ANSI Class 1500 and equivalent PN
inches	mm					
2	50	77	79	82	110	110
3	80	154	165	165	231	254
4	100	209	220	243	419	463
6	150	353	375	452	838	992

Angle Style Body S/A Weights (kg)

Valve		Flanged Connection				
Size		ANSI Class 150 and equivalent PN	ANSI Class 300 and equivalent PN	ANSI Class 600 and equivalent PN	ANSI Class 900 and equivalent PN	ANSI Class 1500 and equivalent PN
mm	in.					
50	2	35	36	37	50	50
80	3	70	75	75	105	115
100	4	95	100	110	190	210
150	6	160	170	205	380	450

Options

Extension Bonnets	Custom Trim Materials
Environmental Capabilities (LE Packing)	U.O.P. Trim Materials
Lubricator & Isolation Valve	Other Materials
Other Flange Facings	Soft Seat (IEC 534-4 and ANSI Class VI)
Limit Stops	Non-Destructive Examination
Body Drain Plug	Oxygen Cleaning
Reducer and Nipple Connections	Electric Actuators
NACE Compliance	

For Accessories and additional Options, please consult GE.

DIRECT SALES OFFICE LOCATIONS

AUSTRALIA

Brisbane:
Phone: +61-7-3001-4319
Fax: +61-7-3001-4399

Perth:
Phone: +61-8-6595-7018
Fax: +61-8-6595-7299

Melbourne:
Phone: +61-3-8807-6002
Fax: +61-3-8807-6577

BELGIUM

Phone: +32-2-344-0970
Fax: +32-2-344-1123

BRAZIL

Phone: +55-19-2104-6900

CHINA

Phone: +86-10-5689-3600
Fax: +86-10-5689-3800

FRANCE

Courbevoie
Phone: +33-1-4904-9000
Fax: +33-1-4904-9010

GERMANY

Ratingen
Phone: +49-2102-108-0
Fax: +49-2102-108-111

INDIA

Mumbai
Phone: +91-22-8354790
Fax: +91-22-8354791

New Delhi

Phone: +91-11-2-6164175
Fax: +91-11-5-1659635

ITALY

Phone: +39-081-7892-111
Fax: +39-081-7892-208

JAPAN

Tokyo
Phone: +81-03-6871-9008
Fax: +81-03-6890-4620

KOREA

Phone: +82-2-2274-0748
Fax: +82-2-2274-0794

MALAYSIA

Phone: +60-3-2161-0322
Fax: +60-3-2163-6312

MEXICO

Phone: +52-55-3640-5060

THE NETHERLANDS

Phone: +31-15-3808666
Fax: +31-18-1641438

RUSSIA

Veliky Novgorod
Phone: +7-8162-55-7898
Fax: +7-8162-55-7921

Moscow

Phone: +7 495-585-1276
Fax: +7 495-585-1279

SAUDI ARABIA

Phone: +966-3-341-0278
Fax: +966-3-341-7624

SINGAPORE

Phone: +65-6861-6100
Fax: +65-6861-7172

SOUTH AFRICA

Phone: +27-11-452-1550
Fax: +27-11-452-6542

SOUTH & CENTRAL

AMERICA AND THE CARIBBEAN

Phone: +55-12-2134-1201
Fax: +55-12-2134-1238

SPAIN

Phone: +34-93-652-6430
Fax: +34-93-652-6444

UNITED ARAB EMIRATES

Phone: +971-4-8991-777
Fax: +971-4-8991-778

UNITED KINGDOM

Bracknell
Phone: +44-1344-460-500
Fax: +44-1344-460-537

Skelmersdale

Phone: +44-1695-526-00
Fax: +44-1695-526-01

UNITED STATES

Massachusetts

Phone: +1-508-586-4600
Fax: +1-508-427-8971

Corpus Christi, Texas

Phone: +1-361-881-8182
Fax: +1-361-881-8246

Deer Park, Texas

Phone: +1-281-884-1000
Fax: +1-281-884-1010

Houston, Texas

Phone: +1-281-671-1640
Fax: +1-281-671-1735

www.geoilandgas.com/valves

*Denotes a trademark of the General Electric Company.
All other marks are the property of their respective owners.

© 2016 General Electric Company. All rights reserved.

